

*Advanced Air Cooled MIG Welding Torch*

# **BLUE TORCH II**

## **OWNER'S MANUAL [Parts List]**

WTA300-SUT . . . 1U5985  
WTA300-MUT . . . 1U6016

# **WTA300-SUT** **WTA300-MUT**

### **Technical Data**

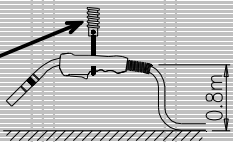
Model :	WTA300-SUT	WTA300-MUT
Rated Current :	300A (MIG)	
Duty Cycle :	30% (Pulse MIG) 、 50% (MIG)	
Wire Size :	1.0mm、1.2mm、1.6mm .040"、3/64"、1/16" (1.2mm / 3/64" Tip is standard.)	
Torch Length :	3.0m/10ft	4.0m/13ft
Net Weight :	3.0kg/6.6lb	3.9kg/8.6lb
Weight at Operating :	1.4kg/3.1lb 	
Cooling Method :	Air Cooled	

# Standard Parts List

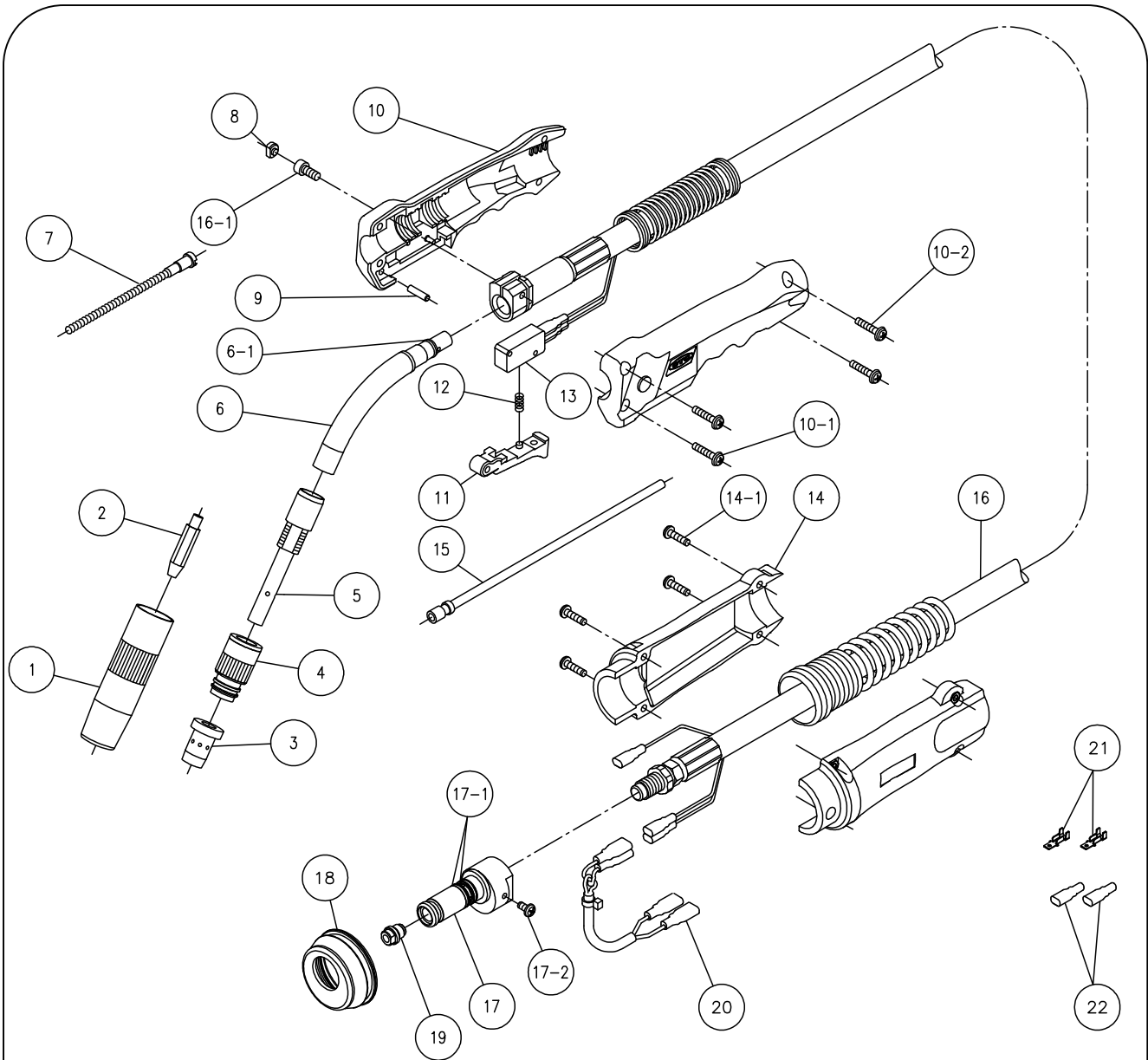

No.	Part Description	Part No.	Remarks
①	Nozzle	U4432G01	I.D.16mm
②	Contact Tip	K980C37	Aluminum 1.2mm / 3/64"
③	Orifice	U4173G02	
④	Insulator	U5377L00	
⑤	Tip Body	U4400G01	
⑥	Torch Body	U4432B00	R100, 45°
⑥-1	O-Ring	3574-124	S9
⑦	Inner Liner	U4432G03	
⑧	Cap	U5341G01	
⑨	Flat Pin	U5035G03	
⑩	Handle	U5035G00	
⑩-1	Small Screw	100-0308	M4×20
⑩-2	Small Screw	100-0306	M4×16
⑪	Trigger	U5035E01	
⑫	Spring	U157E04	
⑬	Micro Switch	4254-137	Dustproof Type

No.	Part Description	Part No.	Remarks
⑭	Cable Support	U5035K00	
⑭-1	Small Screw	100-0306	M4×16
⑮	Plastic Liner (1.0~1.2mm / .040"~3/64")		
	3.0m / 10ft	U4432G02	For "WTA300-SUT"
	4.0m / 13ft	U4527J01	For "WTA300-MUT"
⑯	Power Cable		
	3.0m / 10ft	U5377D00	For "WTA300-SUT"
	4.0m / 13ft	U6016D00	For "WTA300-MUT"
⑯-1	Bolt with Screw	100-0310	M5×14
⑰	Power Fitting	U5972E00	For "NO.4"
⑰-1	O-Ring	100-0818	AS-014(4D)
⑰-2	Small Screw	100-0297	M4×8
⑱	Rubber Sleeve	U5972G01	
⑲	Wire Guide	U5984G02	1.2mm / 3/64"
⑳	Switch Cord	U5972F00	
㉑	Terminal	100-0820	LOM-21T-187
㉒	Cap	100-0821	253224

# Optional Parts List

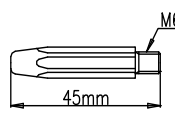
Contact Tip	
	MIG-Tip (Standard)
Wire Size	
1.0mm (.040")	K980C36
1.2mm (3/64")	K980C37
1.6mm (1/16")	K980C38

Plastic Liner		
Wire Size	Length	Part No.
1.6mm (1/16")	3.0m/10ft (For "WTA300-SUT")	U4432G04
1.6mm (1/16")	4.0m/13ft (For "WTA300-MUT")	U6000H00

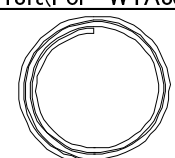

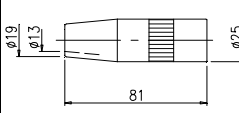
Nozzle	
Low Current	
L6098E09	
	

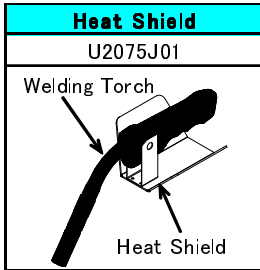

Wire Guide	
Wire Size	Part No.
1.0mm (.040")	U6000G01
1.6mm (1/16")	U6000G02

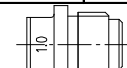

# External View

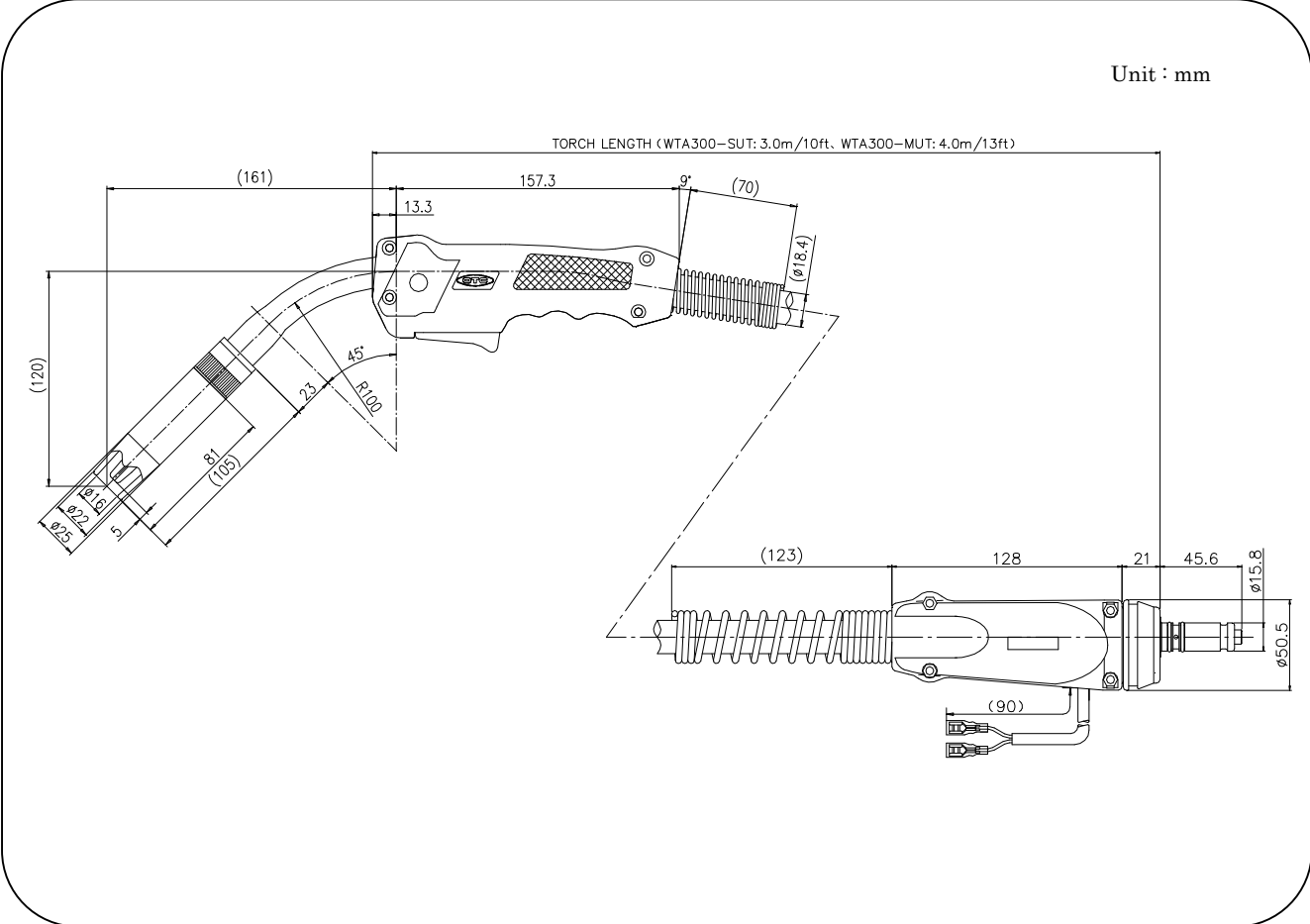

## Torch Type

# WTA 300-SUT



### Direct Plugs

T	:TWECO
D	:OTC
DB	:OTC Black Torch*1
P	:Panasonic
E	:Euro(Binzel)
M	:Miller
MS	:Miller(Separate Gas Hose)
L	:Lincoln
HT	:Hitachi

\*1 OTC black torch Power cable adapter, guide adapter and outlet guide are not attached. The parts that you use now or new parts are required. If new parts are required, order parts below separately.

- Power Cable Adapter U2853G00
- Guide adapter U785C13 (For CM[H]-23Series, CM[H]-14Series)  
U5204J01 (For CM-741)
- Outlet Guide (1.2 / 3/64") U2586F01 (For CM[H]-23Series, CM[H]-14Series)  
U2962M03 (For CM-741)
- Outlet Guide (1.6 / 1/16") U2586F02 (For CM[H]-23Series, CM[H]-14Series)  
U2962M04 (For CM-741)

## Product Line of OTC Blue Torch II Series

Model	WTA 200-SUT	WTA 300-SUT	WTA 300-MUT	WTAW 400-SUT
Rated Current	200A	300A		400A
Duty Cycle	30%(Pulse MIG)/ 60%(MIG)	30%(Pulse MIG)/ 50%(MIG)		100%(Pulse MIG, MIG)
Wire Size (mm / inch) ※	(1.0 / .040") 1.2 / 3/64"	(1.0 / .040") 1.2 / 3/64" (1.6 / 1/16")		1.2 / 3/64" (1.6 / 1/16")
Torch Length	3.0m/10ft	3.0m/10ft	4.0m/13ft	3.0m/10ft
Net Weight	2.5kg/5.5lb	3.0kg/6.6lb	3.9kg/8.6lb	2.7kg/6.0lb
Cooling Method	Air Cooled	Air Cooled		Water Cooled

※In case of using wire size in the parenthesis, separate sale items are required.

## Attention

Do not pull or move the wire feeder with welding torch, otherwise breaking of the power cable and the cable coating would be tear. If the conductor becomes expose, you may be got electric shocked.

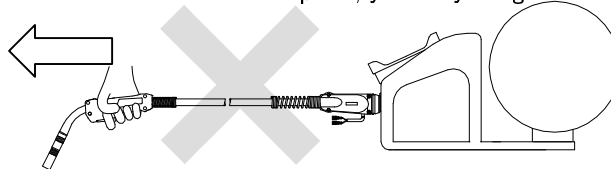

Exchange the power cable when it is damaged. Do not disassemble or repair on damping part.

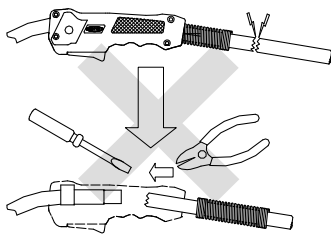

In the case of damaging the O-ring, please exchange it. If the damaged O-ring is used as it is, it may cause welding defect.

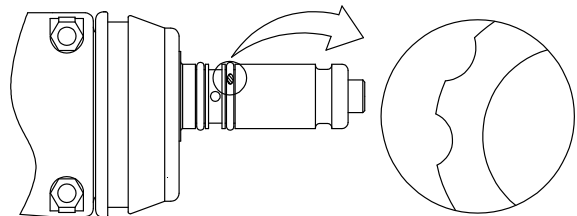

**DAIHEN, INC.**  
**DAYTON OFFICE**  
1400 Blauser Drive  
Tipp City, OH 45371, U.S.A  
Phone : +1-937-667-0800  
Fax : +1-937-667-0885

**DAIHEN Corporation**  
4-1, Koyochonishi,  
Higashinada-ku, Kobe  
Hyogo, 658-0033, Japan  
Phone : +81-78-275-2004  
Fax : +81-78-845-8158

**OTC DAIHEN EUROPE**  
**GmbH.**  
Krefeder Strasse 677  
D-41066 Mönchengladbach,  
F.R. GERMANY  
Phone : +49-2161-6949710  
Fax : +49-2161-6949711

**OTC(Taiwan)Co.,Ltd.**  
No.63-4,Nan Yuan 2 Rd.,  
Chung Li, Taoyuan Hsien,  
Taiwan R.O.C.  
Phone : +886-3-461-3962  
Fax : +886-3-434-2394

**OTC DAIHEN Asia Co.,LTD.**  
60/86 Moo 19, Navanakorn  
Industrial Estate Phase 3,  
Klong Nueng, Klong Luang,  
Pathumthani 12120, Thailand  
Phone : +66-2-909-4163  
Fax : +66-2-909-4166

**OTC Industrial(Shanghai)**  
**Co.,Ltd.**  
7G Majisty Buiding, 138 Pu  
Dong Da Dao Shanghai The  
People's Republic of China  
Post Code: 200120  
Phone : +86-21-58828633  
Fax : +86-21-58828846