

Thank you for purchasing DAIHEN shock sensor built-in type CO₂ /MAG welding torch.
Before use, read this instruction manual thoroughly to use the product correctly.

- [Note] 1. The contents in this instruction manual are subject to change without prior notice.
2. We have carefully written the standard specifications to eliminate as many errors as possible. Even if any errors are found in the contents, we are not responsible for any damage resulting from those errors.
3. No part of this instruction manual may be reproduced or stored in any form without the express written permission.

1. Specifications

This is the “Shock sensor built-in type welding torch” to be used for CO₂/MAG welding.
The specifications are shown in Table 1.1. (Refer to Fig. 1.1 ~1.3 for the outline drawing.)

Table 1.1 Specifications of welding torch

Model	MTX-3531	MTXC-3531	MTXB-3531	MTXCB-3531	MTX-5031	MTXC-5031	MTXB-5031	MTXCB-5031	MTXW-5031	MTXCW-5031
Torch type	Straight	Curved	Straight	Curved	Straight	Curved	Straight	Curved	Straight	Curved
Welding process	CO ₂ (MAG)									
Max. operating current	350A (250A)				500A (300A)				500A (350A)	
Rated duty cycle	50%				50%				70%	
Wire type	Solid wire, Flux cored wire									
Applicable wire diameter	(φ 0.8)(φ 0.9)(φ 1.0) φ 1.2 (φ 1.4)(φ 1.6)								(φ 0.8)(φ 0.9) (φ 1.0)(φ 1.2) (φ 1.4) φ 1.6	
Cooling system	Air cooling								Water cooling	
Nozzle cleaning function	-	Air-blow		-	Air-blow		-			
Shock sensor	Built-in									

- Note) 1. While using MTXW-5031 and MTXCW-5031, be sure that cooling water is being supplied with the water tank (PU-301).
2. The maximum operating current and rated duty cycle are different between CO₂ and MAG welding system.
3. The model MTXB-3531, MTXCB-3531, MTXB-5031 and MTXCB-5031 shall be used accompanied with the air-blow unit. (Refer to the section 3.5.)
4. Shock sensor function
In the Arc welding system, a welding torch may collide with a workpiece or jig, resulting in its deformation, or the robot body may get damaged. To avoid such an accident, this welding torch has the shock sensor function, which stops the robot motion immediately when excess force is applied on the torch tip (nozzle part), by keeping the nozzle part away and outputting the excess force detection signal at a time.
(* However, this function does not guarantee the torch positioning accuracy. After the shock sensor was activated, ensure the torch aiming point.) (See the section 5.2.)

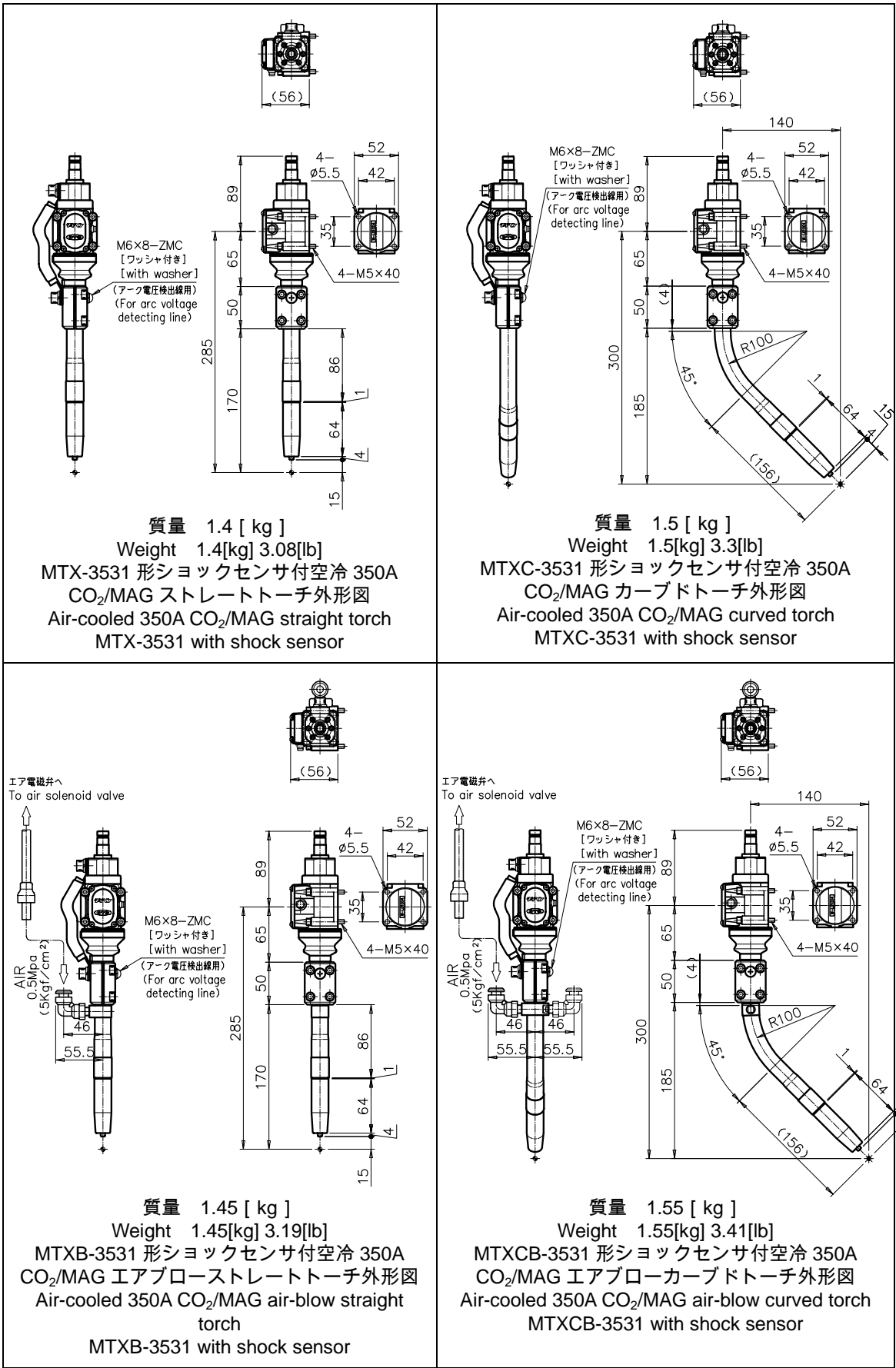
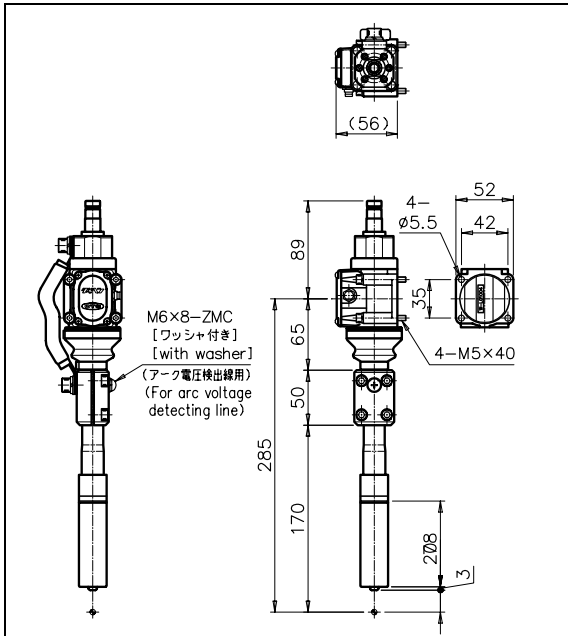

Fig.1.1 Outline drawing of air-cooled 350A torch Unit (mm)



質量 1.5 [kg]

Weight 1.5[kg] 3.3[lb]

MTX-5031 形ショックセンサ付空冷 500A
CO₂/MAG ストレートトーチ外形図
Air-cooled 500A CO₂/MAG straight torch
MTX-5031 with shock sensor

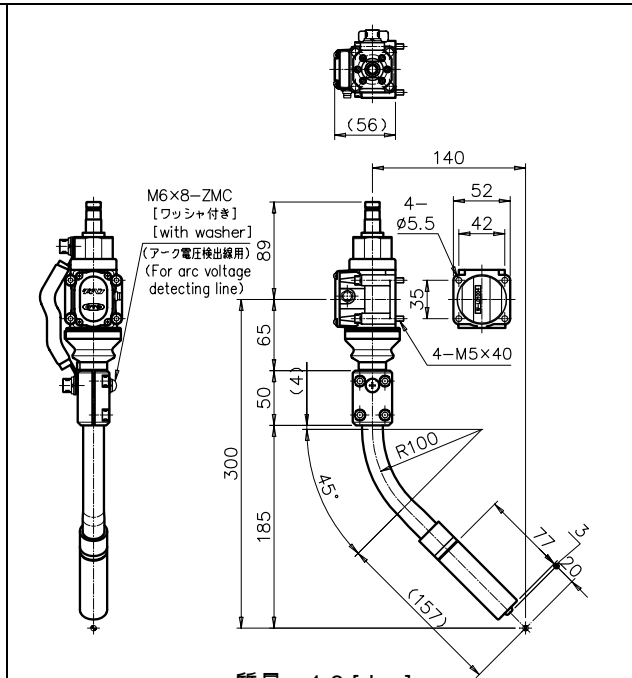

質量 1.6 [kg]

Weight 1.6[kg] 3.52[lb]

MTXC-5031 形ショックセンサ付空冷 500A
CO₂/MAG カーブドトーチ外形図
Air-cooled 500A CO₂/MAG curved torch
MTXC-5031 with shock sensor

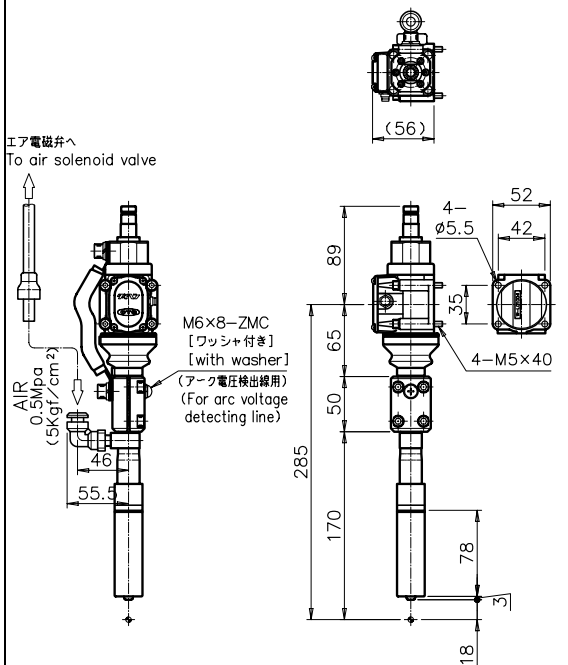

質量 1.65 [kg]

Weight 1.65[kg] 3.63[lb]

MTXB-5031 形ショックセンサ付空冷 500A
CO₂/MAG エアブローストレートトーチ外形図
Air-cooled 500A CO₂/MAG straight torch
MTXB-5031 with shock sensor

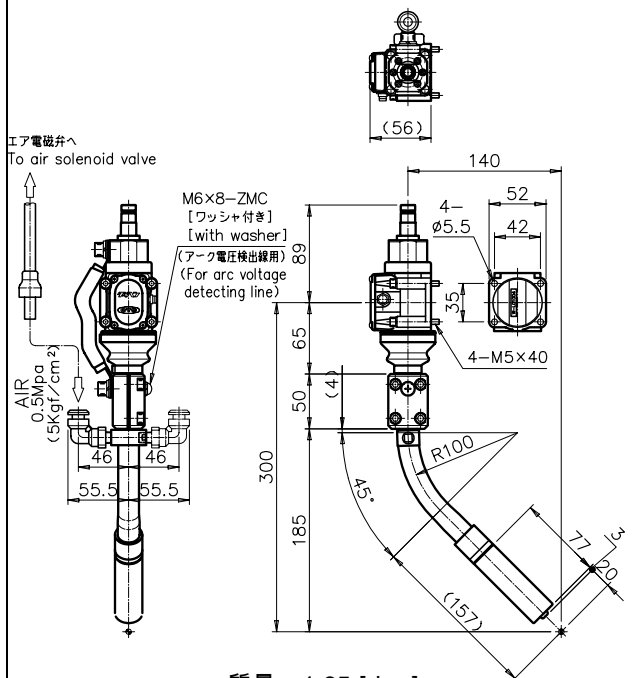

質量 1.65 [kg]

Weight 1.75[kg] 3.85[lb]

MTXCB-5031 形ショックセンサ付空冷 500A
CO₂/MAG エアブローカーブドトーチ外形図
Air-cooled 500A CO₂/MAG curved torch
MTXCB-5031 with shock sensor

Fig.1.2 Outline drawing of air-cooled 500A torch Unit (mm)

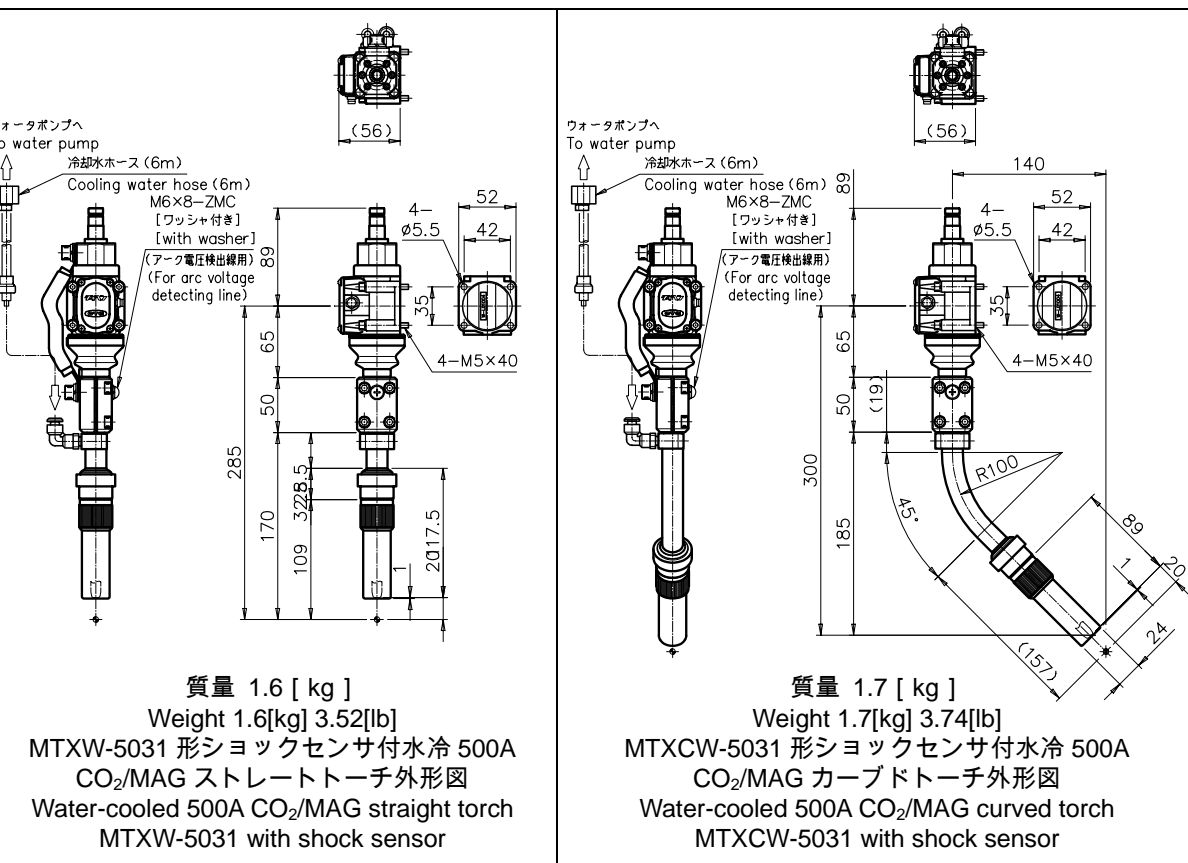

Fig.1.3 Outline drawing of water-cooled 500A torch Unit (mm)

2. Checking the Contents





MTX-3531 MTXB-3531	MTXC-3531 MTXCB-3531
  <p>溶接トーチ本体 / Welding torch main body 取付ボルト / Mounting bolt (M5×40) …… 4 本 / 4 pieces パネ座金 / Spring washer (M5) …………… 4 個 / 4 pieces</p>	  <p>溶接トーチ本体 / Welding torch main body 取付ボルト / Mounting bolt (M5×40) …… 4 本 / 4 pieces パネ座金 / Spring washer (M5) …………… 4 個 / 4 pieces</p>
MTX-5031 MTXW-5031 MTXB-5031	MTXC-5031 MTXCW-5031 MTXCB-5031
  <p>溶接トーチ本体 / Welding torch main body 取付ボルト / Mounting bolt(M5×40) …… 4 本 / 4 pieces パネ座金 / Spring washer(M5) …………… 4 個 / 4 pieces スパナ / Wrench …………… 1 個 / 1 piece (MTXW-5031 のみ / only for MTXW-5031) 冷却水ホース / Hose for cooling water(6m) ・2 本 / 2 pieces (MTXW-5031 のみ / only for MTXW-5031)</p>	  <p>溶接トーチ本体 / Welding torch main body 取付ボルト / Mounting bolt(M5×40) …… 4 本 / 4 pieces パネ座金 / Spring washer(M5) …………… 4 個 / 4 pieces スパナ / Wrench …………… 1 個 / 1 piece (MTXW-5031 のみ / only for MTXW-5031) 冷却水ホース / Hose for cooling water(6m) ・2 本 / 2 pieces (MTXW-5031 のみ / only for MTXW-5031)</p>

Fig. 2.1 Checking the contents

Note) 1. Use of the MTXW-5031/MTXCW-5031 water-cooled torch requires a water tank. Purchase the water tank (PU-301) separately.

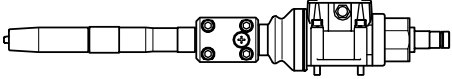
2. Use of the MTXB-3531/MTXCB-3531/MTXB-5031/MTXCB-5031 air-blow torch requires the air-blow hose and air-blow unit. Purchase the air-blow unit separately according to the manipulator type as shown below.

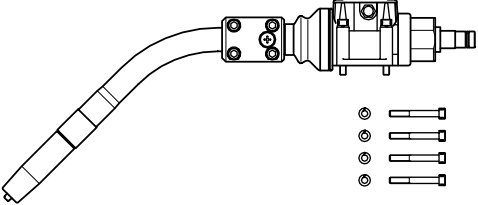
・ L6607A : DR4000, DR4200, DR4300, DR4400, DR4200L, DR3000, DR3200, DR603, DR606, and DR610

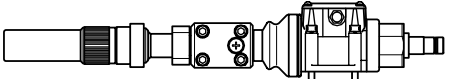
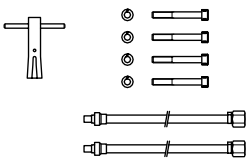
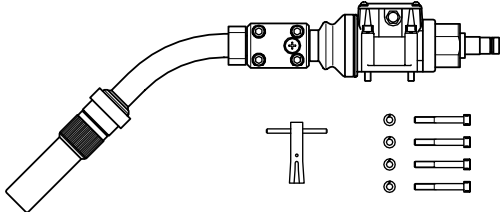
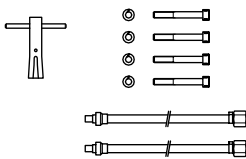
・ L7470A : Almega AX(EX)-V6, 16, 06L, AX(EX)-G3

・ L10121A : Almega AX-V4AP

3. The above mounting bolt (M5×40) is to mount the torch on the mounting bracket..

4. A wrench is used for removing the contact tip.

Installing and Adjusting Procedure of Welding Torch

3.1 Mounting on Almega V-type Manipulator

3.1.1 Mounting the curved torch (mounting bracket)

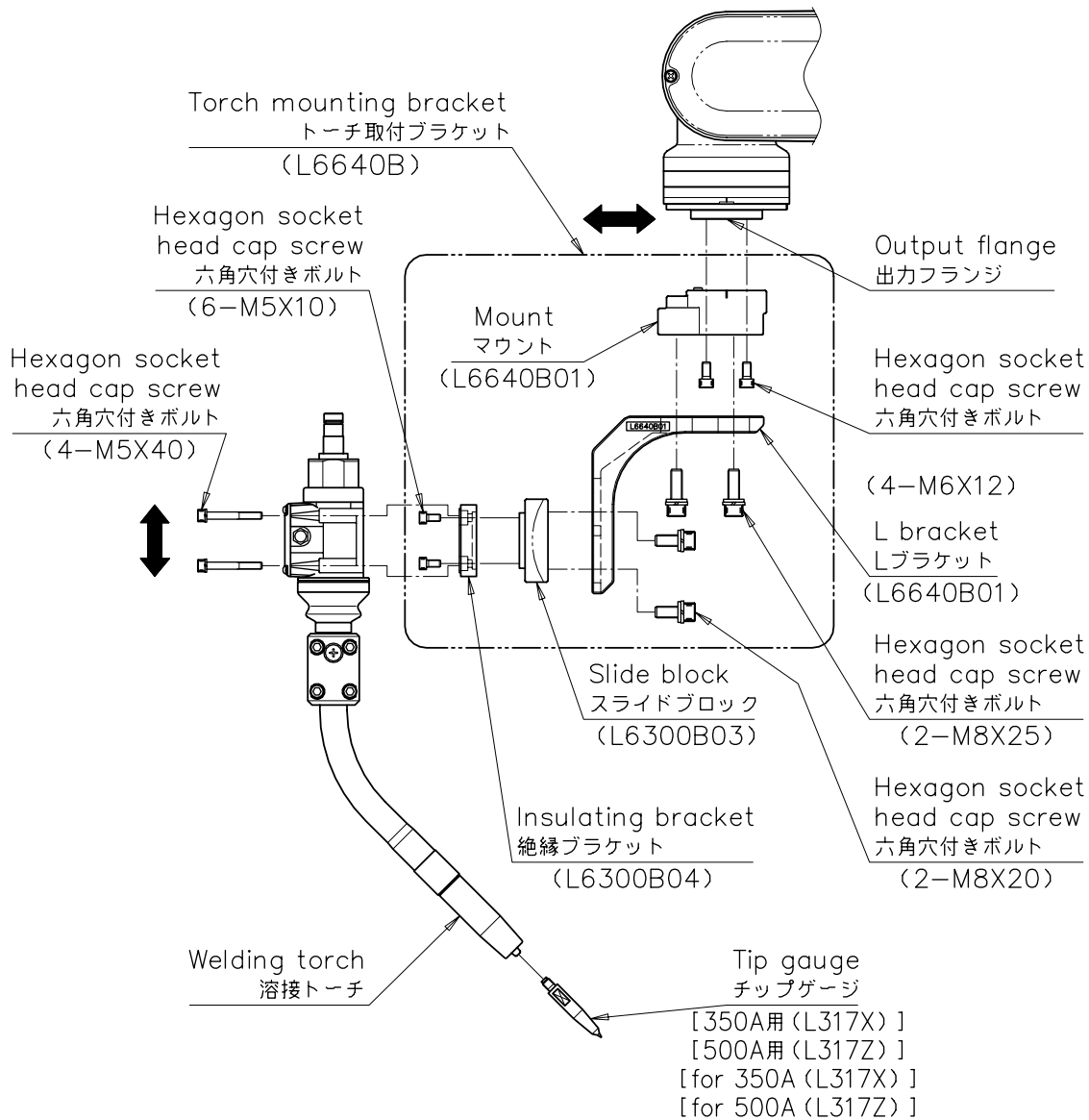

(Note: Purchase the torch mounting bracket ASSY separately.)

Fig. 3.1 Mounting the torch and bracket

3.1.2 Mounting the torch gauge

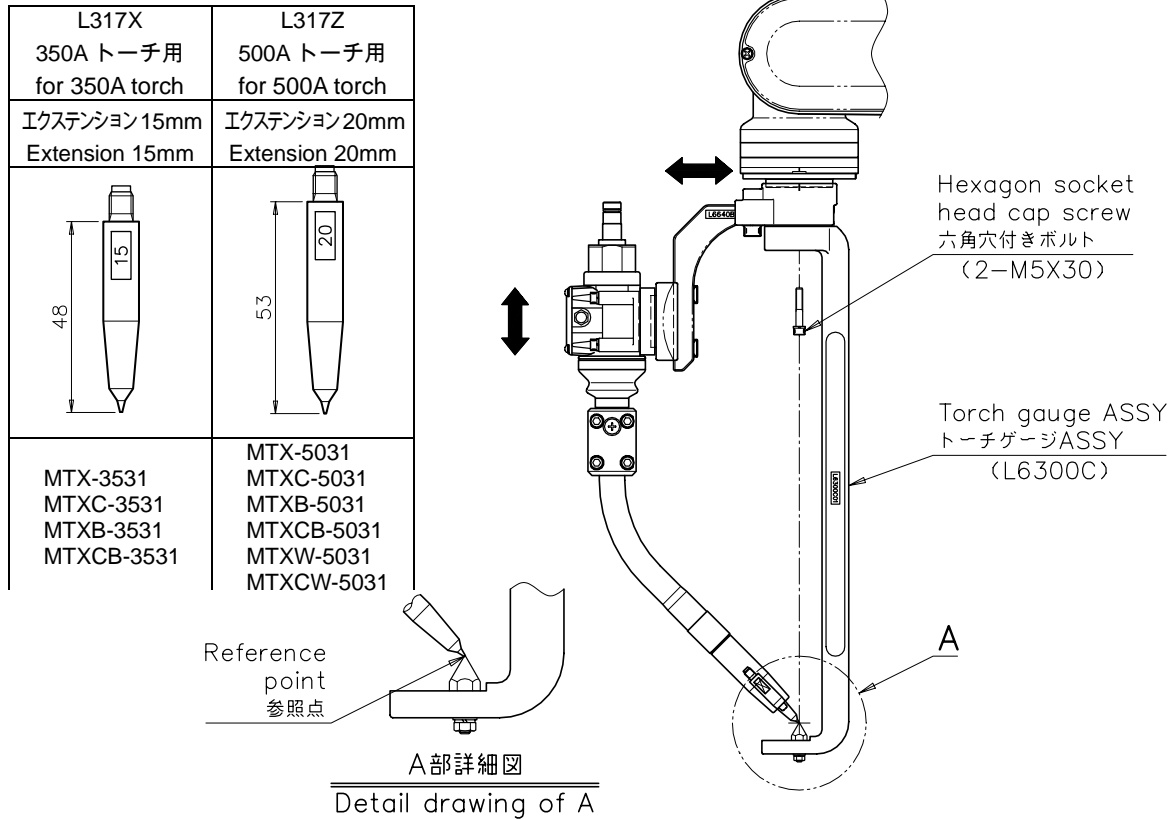

(Note: Purchase the torch gauge ASSY separately.)

Fig. 3.2 Mounting the torch gauge

3.1.3 Adjusting procedure of the torch

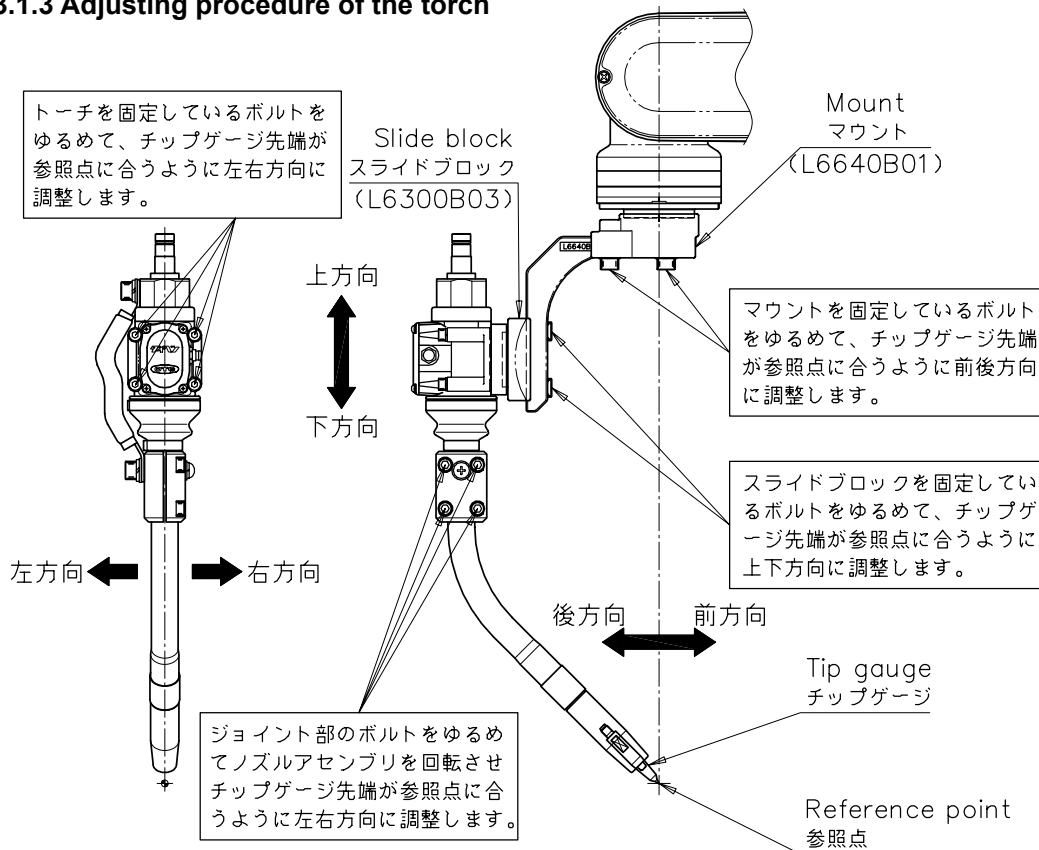

Fig. 3.3 Adjusting procedure of the torch

3.2 Mounting on Almega G-type Manipulator

3.2.1 Mounting the straight torch (mounting bracket)

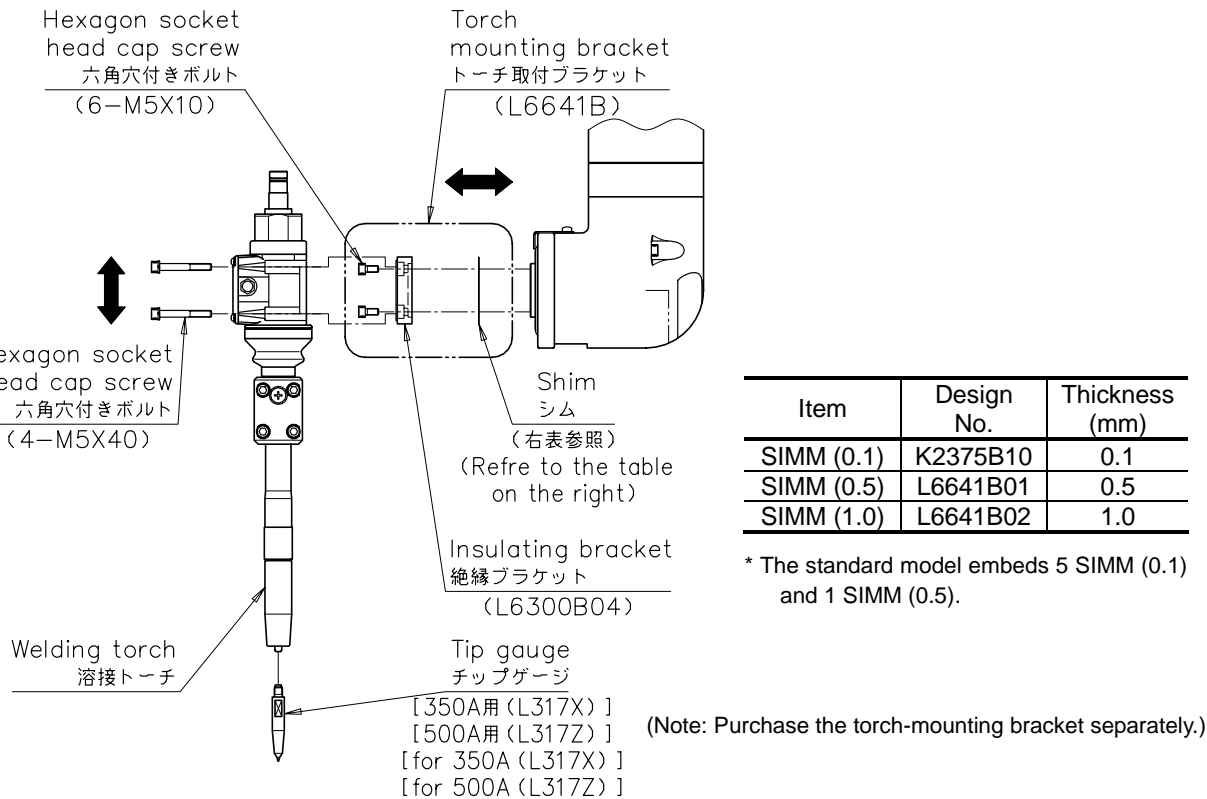

Fig. 3.4 Mounting the torch and bracket

3.2.2 Mounting the torch gauge

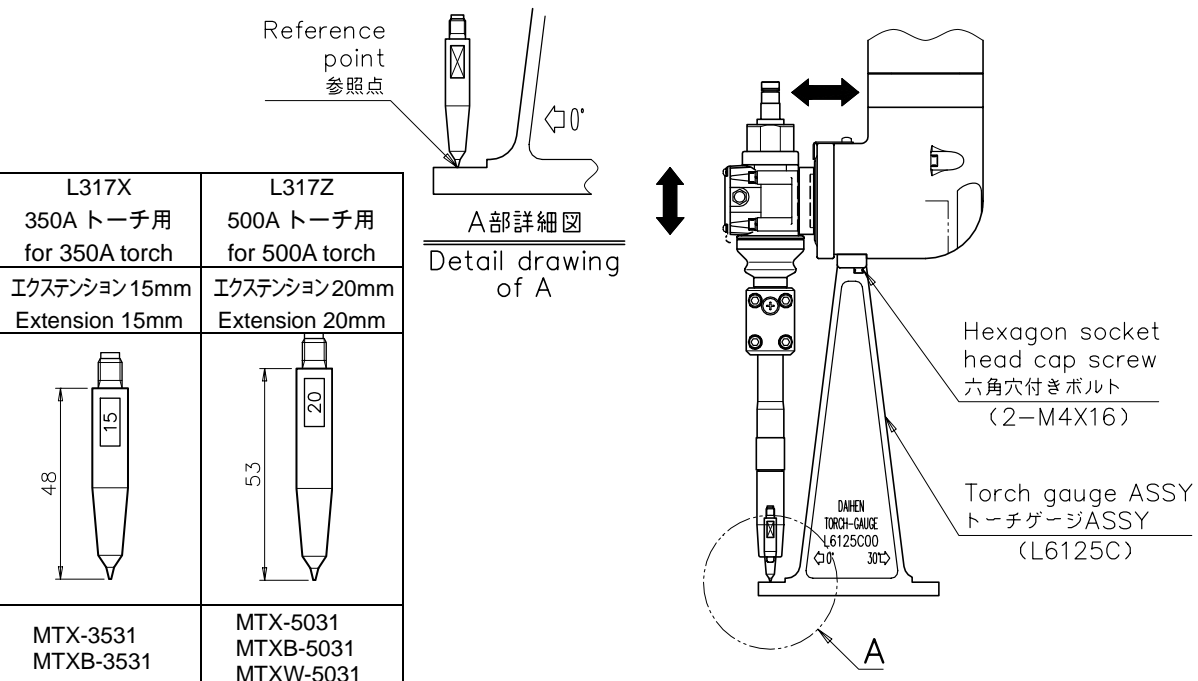

Fig. 3.5 Mounting the torch gauge

3.2.3 Adjusting procedure of the torch

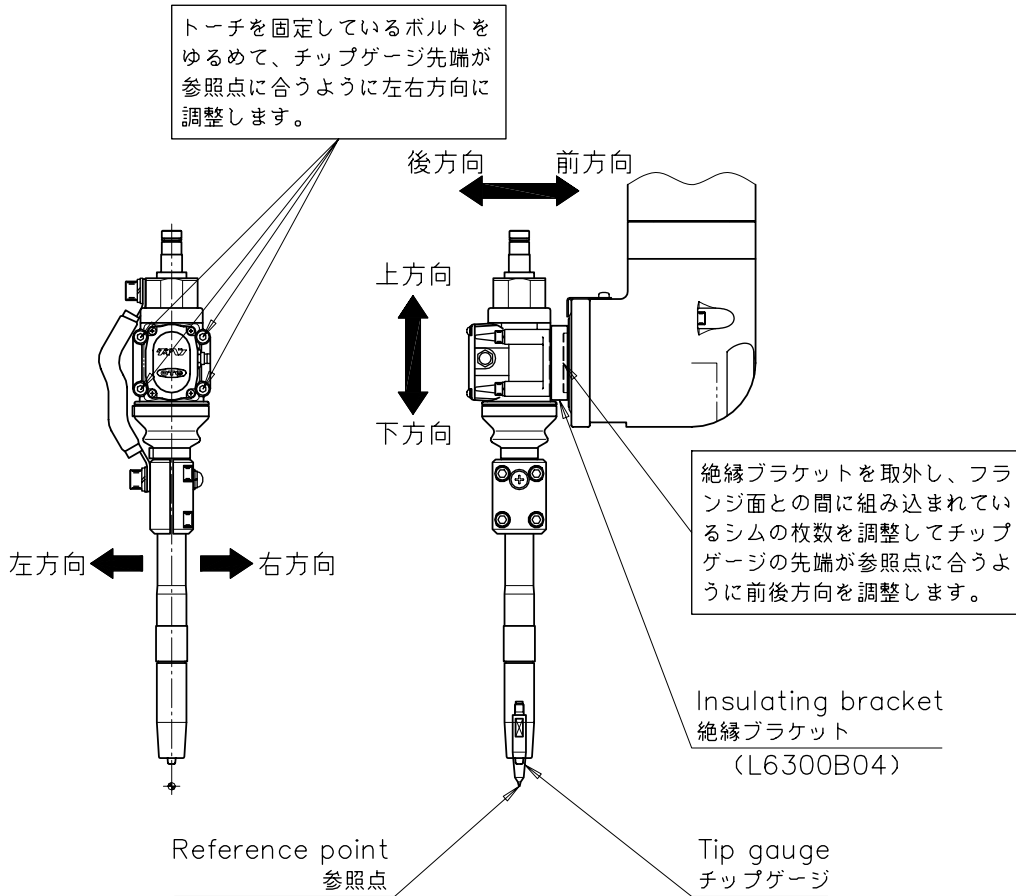

Fig. 3.6 Adjusting procedure of the torch

3.3 Mounting on Almega AX-V4AP/V4L4P

3.3.1 Mounting the curved torch (mounting bracket)

- (1) Fix the bracket (L10100B01) with 4 pieces of hexagon socket head cap screws (M5*10) onto the output flange of manipulator.
- (2) Insert the insulating sleeve (L10100B04) into the bracket (L10100B01) fixed in the procedure (1), and fix the insulating board (2) shown in the Fig.3.8 with 4 pieces of resin bolts (M3*6). In the same way, fix the insulating board (1) (L10100B02) with 4 pieces of resin bolts (M3*6) to the bracket.
- (3) Fix the insulating bracket (L6300B04) to the bracket (L10100B01) with 6 pieces of hexagon socket head cap screws (M5*10), and the spatter cover (L10100B05) to the bracket with 2 pieces of hexagon socket head cap screws (M5*12).
- (4) Mount the torch to the insulating bracket with 4 pieces of hexagon socket head cap screws (M5*40) that come with the torch.
- (5) Lead the coaxial power cable into the location shown in Fig.3.7, and connect it to the wire feeding unit.

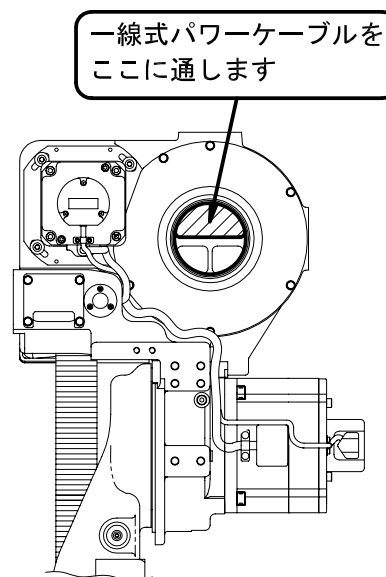

Fig. 3.7 Location of leading the coaxial power cable

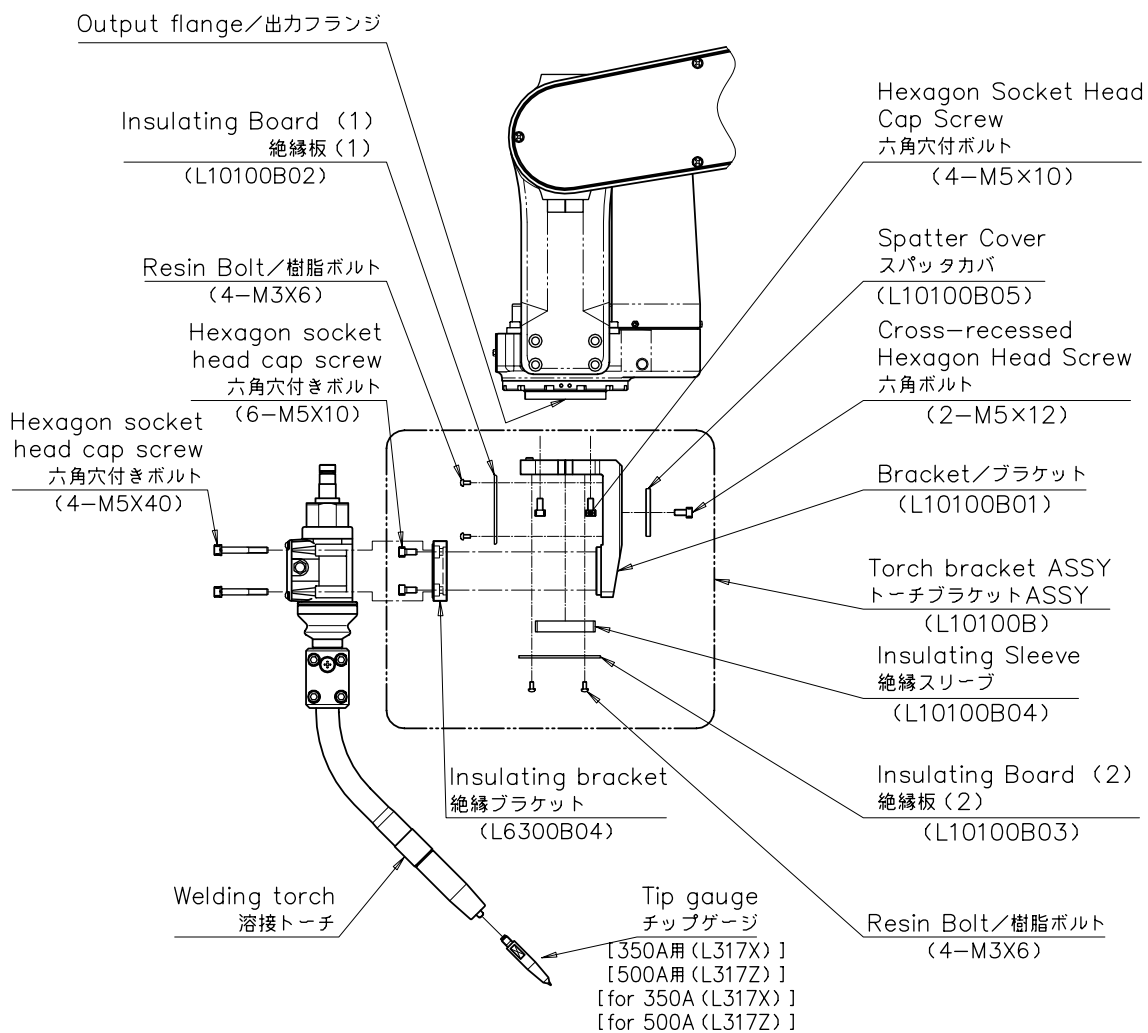

Fig. 3.8 Mounting the curved torch (MTXC-3531)

3.3.2 Teaching the reference point (Creating the origin position check program)

- (1) Remove the nozzle and contact tip from the torch.
- (2) Secure the tip gauge (L317X) to the torch.
- (3) To set the reference point, prepare the sharp point fixed on the ground (such as the tip gauge L317X). (Hereinafter, referred to as the reference gauge.)
- (4) Align the point of tip gauge on the tip of reference gauge, and teach it as the reference point 2 (point-teaching). This reference point 2 is used for checking the mechanical deviation of torch.

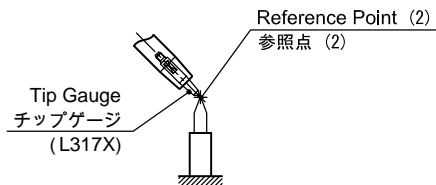

Fig. 3.9 Teaching the reference point

3.3.3 Mounting the gauge ASSY (Option)

- 1) Remove the nozzle and contact tip from the torch.
- 2) Secure the tip gauge (L317X) to the torch.
- 3) Remove the spatter cover (L10100B05) attached to the bracket (L10100B01), and fix the gauge ASSY with 2 pieces of hexagon socket head cap screws (M5*30) that come together.
- 4) To set the reference point, prepare the sharp point fixed on the ground (such as the tip gauge L317X).
(Hereinafter, referred to as the reference gauge.)

Note) This gauge is for checking the current position of robot. (It is not available to estimate the torch positioning accuracy using this torch gauge although available by the conventional torch gauge.)

>> For adjustment, see the section 3.3.4.

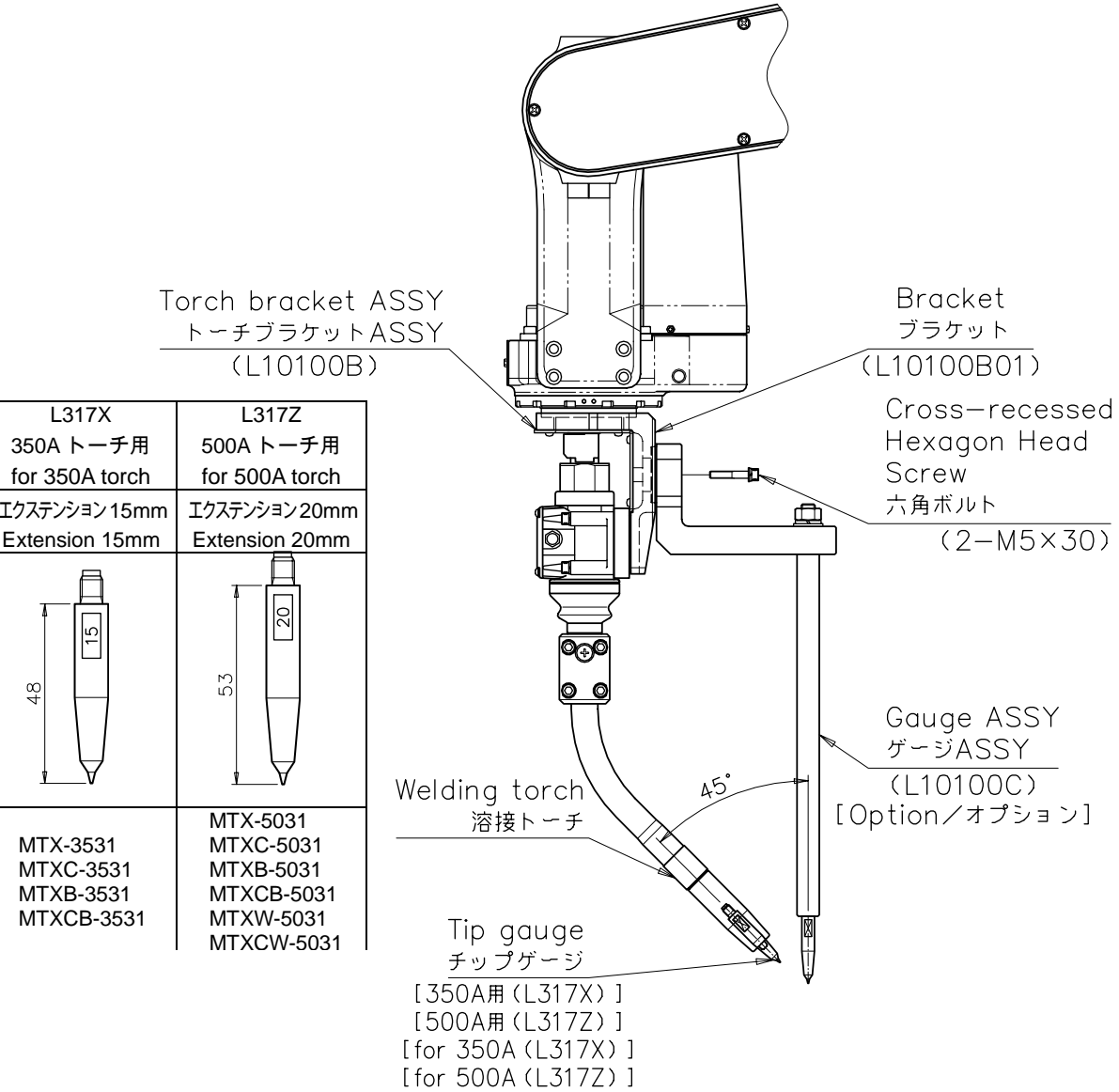

Fig. 3.10 Mounting the gauge ASSY

3.3.4 Teaching the reference point using the gauge ASSY (Option)

(Creating the origin position checking program)

- (1) Align the point of gauge ASSY with the reference gauge prepared when the gauge ASSY was installed, and teach it as the reference point (1) (point-teaching). This reference point (1) is used for checking the mechanical deviation of robot.
- (2) Align the point of tip gauge secured on the torch tip with the tip of reference gauge, and teach it as the reference point (2) (point-teaching). This reference point (2) is used for checking the mechanical deviation of torch.

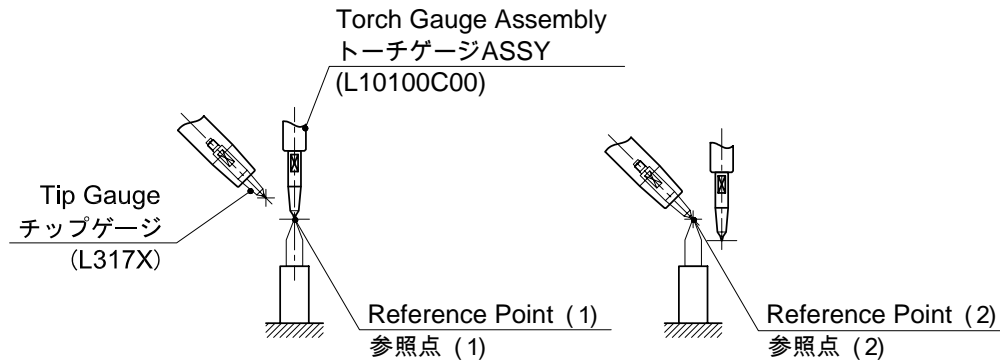

Fig. 3.11 Teaching the reference point

3.3.5 Daily check of reference point

In the daily check, see if no deviation has occurred in the reference point 2 taught by the origin position check program. If any deviation has occurred caused by the torch collision etc., correct it as instructed in [Fig. 3.12 Checking procedure when the torch deviated](#)

If a deviation has occurred in the reference point 1 taught by the origin-position check program, provided with the gauge ASSY (option), that deviation shall be attributed to the manipulator.

Contact our sales department.

If no deviation has occurred in the reference point 1, that deviation shall be attributed to the torch. In this case, correct it by the following procedure.

Note that when checking the reference point 1 first taught, be sure to use the gauge applied in the first.

If using a wrong gauge, the precise position accuracy cannot be obtained.

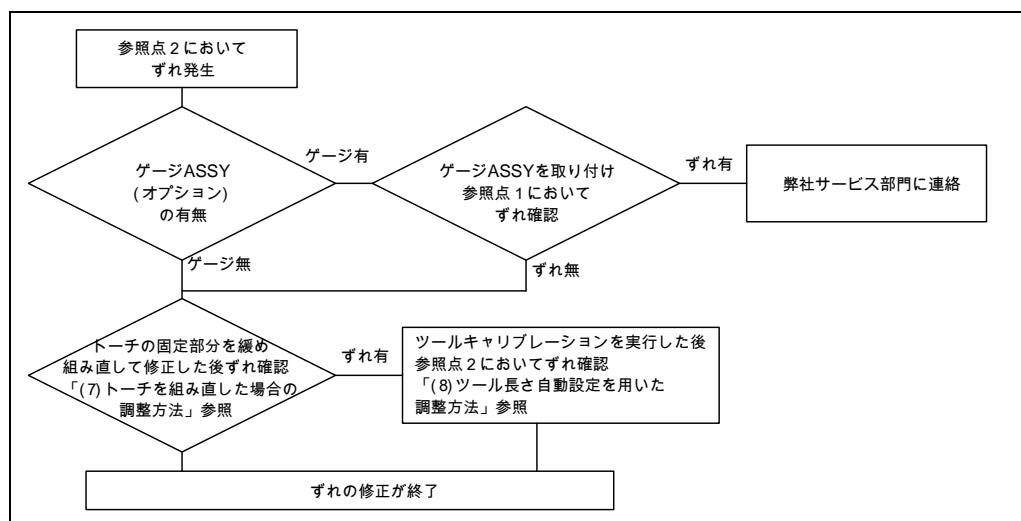

Fig. 3.12 Checking procedure when the torch deviated

3.3.6 Adjustment procedure after the torch reassembled

Loosen the bolt that fixes the torch, and adjust its deviation as shown in Fig.3.13.
 After adjusting, check that no deviation has occurred in the reference point 2.

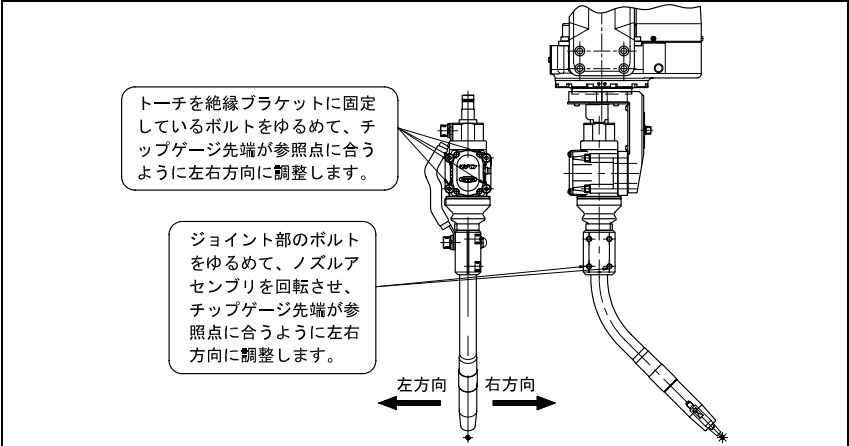

Fig. 3.13 Deviation adjustment in torch

3.3.7 Adjustment procedure with the tool length automatic setting

- (1) Copy the existing origin position check program (Program "A" for example), and newly create the program B. Running this program B, align the tip of reference gauge and the point of tip gauge fixed on the torch tip by performing the **rectangular manual operation holding the torch posture** from the position of program A to perform teaching (point-teaching).

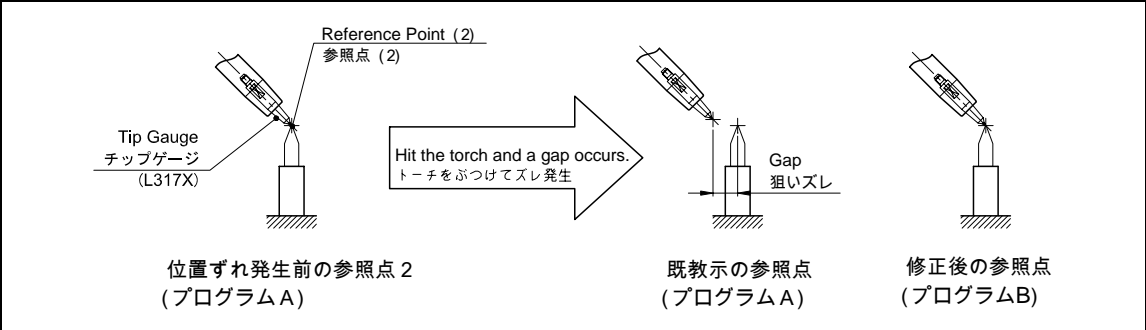

Fig. 3.14 Checking the reference point

- (2) Perform the 2-point tool length setting. With this setting, the amount of torch (tool) deviation can be automatically reflected to the program. For details of the operation procedure, see the instruction manual; section 4.5.2 "Tool length" in INSTALLATION.
- (3) As the tool conversion function is automatically executed, follow the instruction and convert the program that you would like to perform the tool conversion. For details of the operation procedure, see the instruction manual; section 4.5.8 "Tool conversion" in INSTALLATION.
- (4) Call the program A and check that the deviation in the reference point 2 has been corrected, having a proper reference point.

In addition, do not execute the tool conversion function in the program where the reference point 1 has been taught with the optional gauge ASSY provided.

If executing the tool conversion function in all the programs, teach the reference point 1 again.

3.4 Connecting the Water-cooled Torch (MTXW-5031/MTXCW-5031)

3.4.1 For other than AX-V4AP

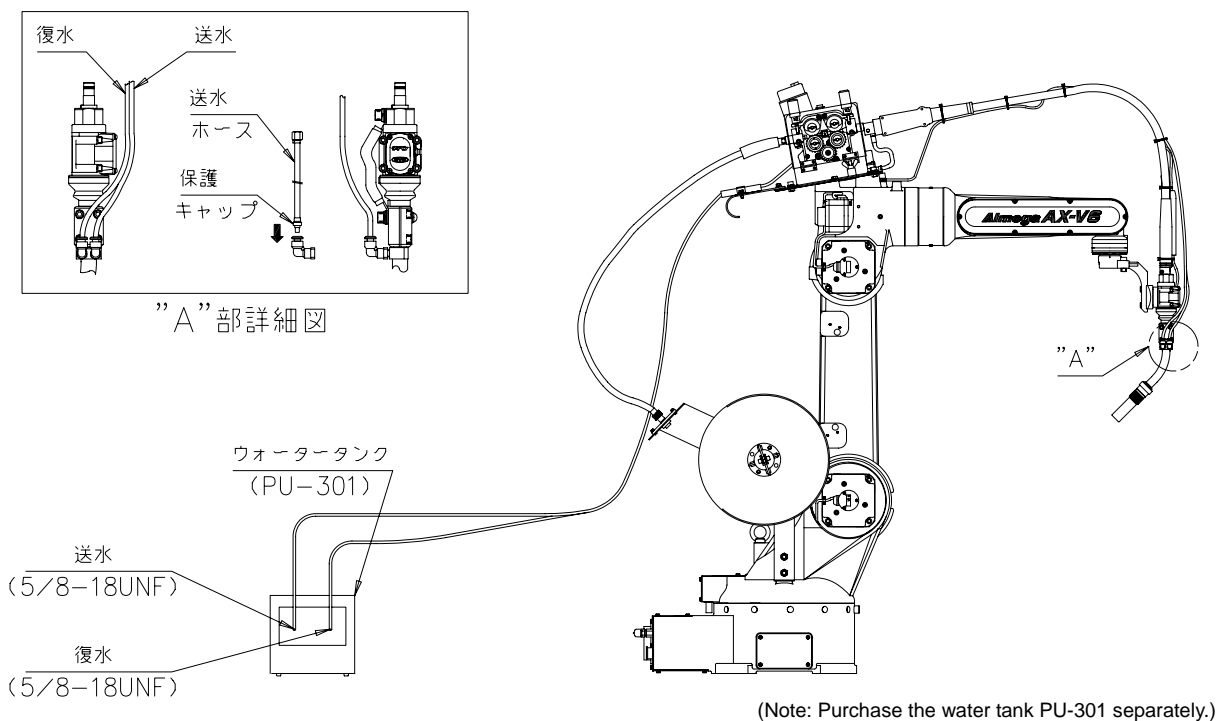

Fig. 3.15 Connection procedure of water-cooled torch

3.4.2 For AX-V4AP

To connect the water-cooled torch to AX-V4AP, the hose installation KIT (L7898P) is separately required.

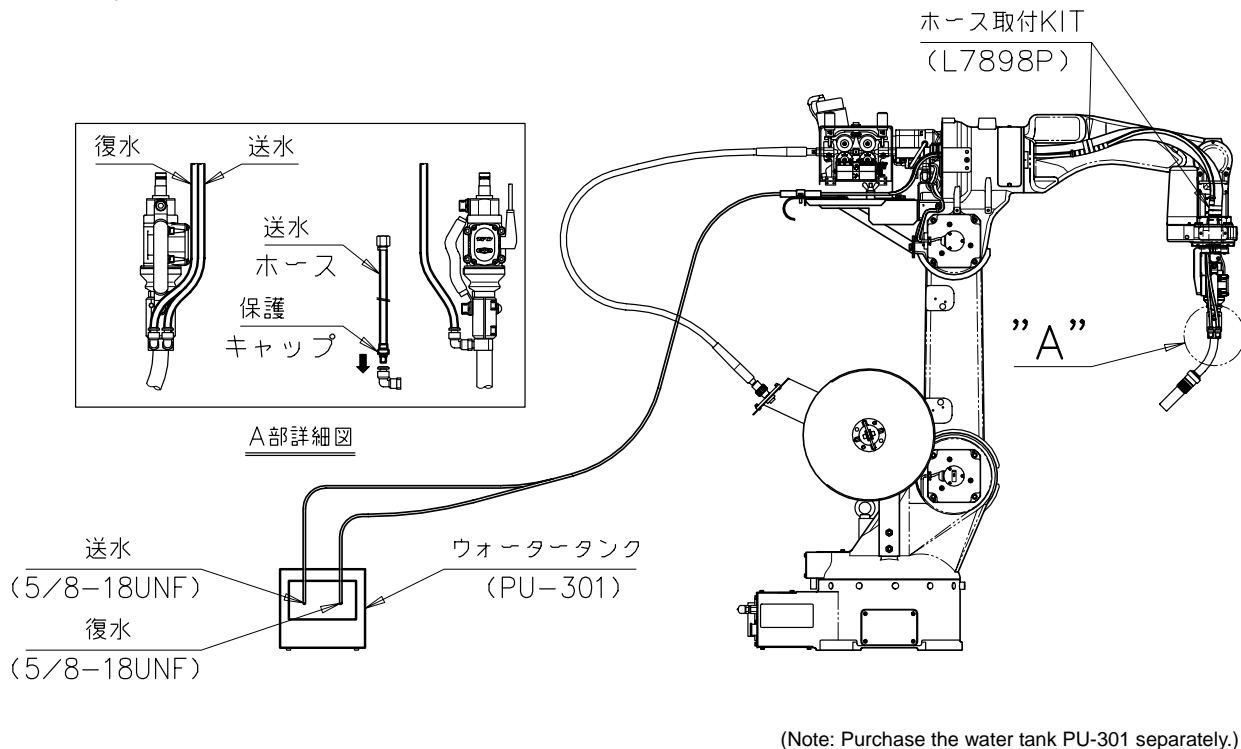

Fig. 3.16 Connection of water-cooled torch (For AX-V4AP)

3.5 Connecting the Air-blow Unit (Torch)

The model of manipulator determines a type of air-blow unit to be used. Choose a proper one according to the manipulator that you apply.

- ・ DR 4000/4200/4200L/4300/4400/3000/3200 : L6607A
- ・ Almega AX/EX series : L7470A
- ・ Almega AX-V4AP : L10121A

3.5.1 For other than AX-V4AP/V4L4P

(Applicable torch : MTXB-3531, MTXCB-3531, MTXB-5031, MTXCB-5031)

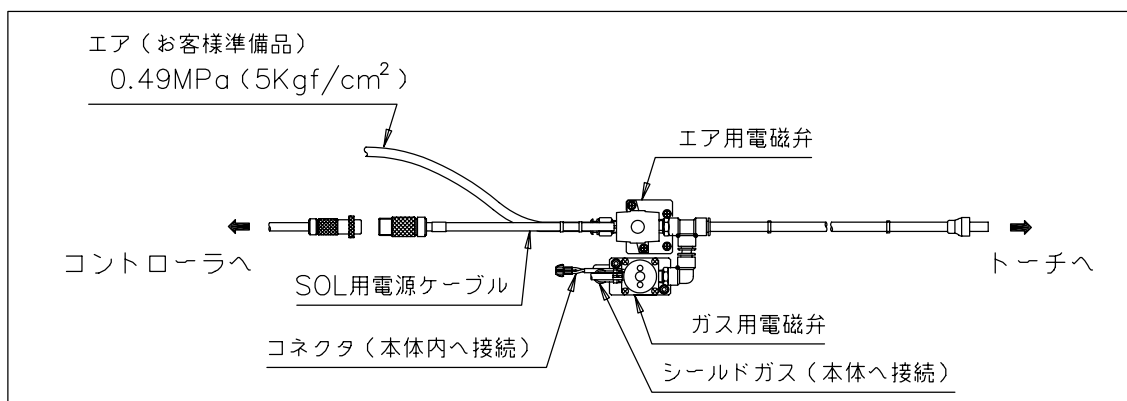

構成図（マニピュレータ上部）

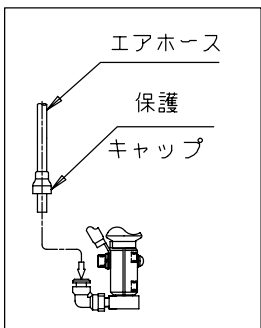
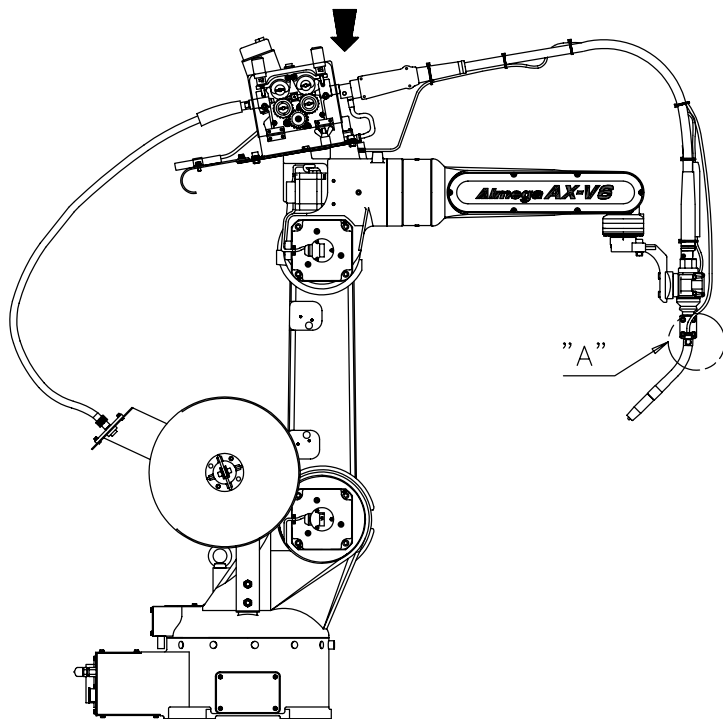

”A”部詳細図

(Note: Purchase the air-blow unit separately.)

Fig. 3.17 Connection of air-blow unit (torch) [Almega AX/EX series]

3.5.2 For AX-V4AP

(Applicable torch : MTXCB-3531, MTXCB-5031)

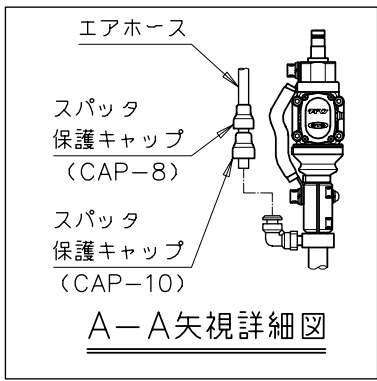
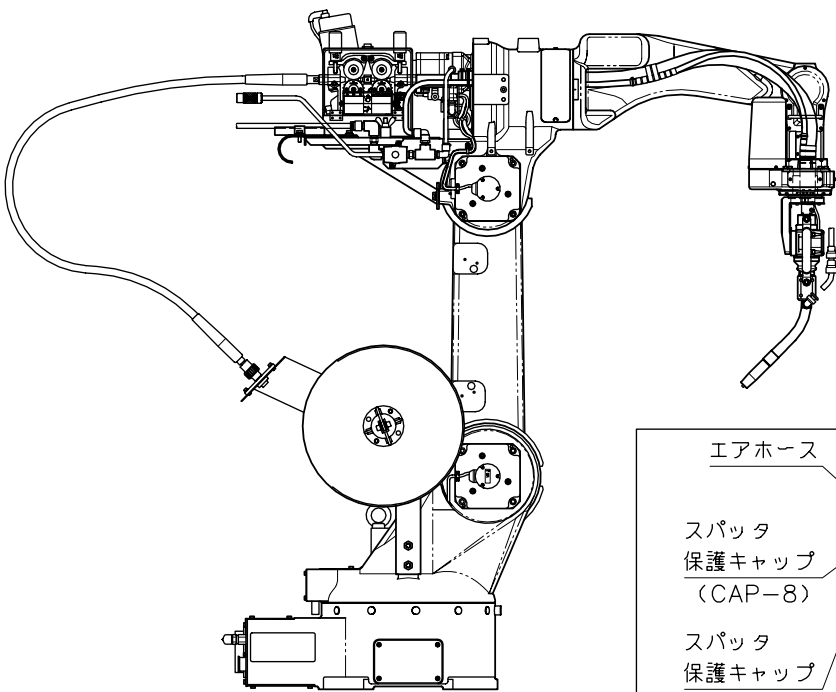
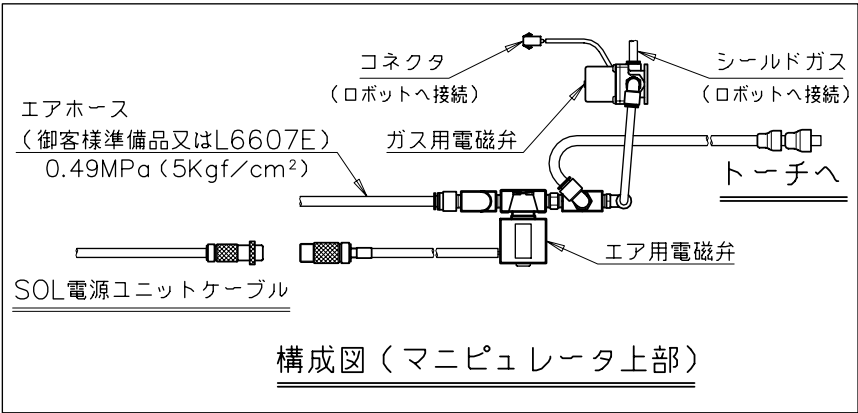

(Note: Purchase the air-blow unit separately.)

Fig. 3.18 Connection of air-blow unit (torch) [Almega AX-V4AP]

i IMPORTANT

When connecting the water-cooled/air-blow hose to AX-V4AP, refer to the section 3.6. (Check the condition of hose with the robot in motion.) Neglect of the instruction described in the section 3.6 may cause a failure while the robot is in motion to result in a poor welding performance.

3.6 Connecting the Hose (water-cooled/air-blow) to AX-V4AP

1. Remove the power cable guide.
2. Arrange the hose along the coaxial power cable.
3. Connect the hose to the torch arranging along the coaxial power cable. (Lead the hose in the location as shown in Fig. 3.19.)
4. Bind up the hose and coaxial power cable with a spiral tube.
 - (1) Bind the spiral tube from the torch side as shown in *1 ~ *2.
 - (2) Bind the spiral tube from the W/F side as shown in *3 ~ *5.

[Note] Have enough slack in the section (*) in Fig.3.20.

5. Adjust the slack in the tube.
 - (1) Make the robot posture upright and horizontal.
 - (2) Rotate the 6th axis to the maximum (soft limit), and check that no stress is applied to the hose. [Both +/- side]
 - (3) Rotate the 6th axis to the maximum (soft limit) in either + or - side, and 4th axis in the other side of the 6th axis to the maximum (soft limit), and then check that no stress is applied to the hose.
 - (4) Rotate both the 4th and 6th axis to the maximum (soft limit) respectively in the other side of the above operation (3), and check that no stress is applied to the hose.
6. Check the slack of hose, and secure the spiral tube at its end with a binding band.
7. Bind the hose and coaxial power cable on the W/F side with a binding band.

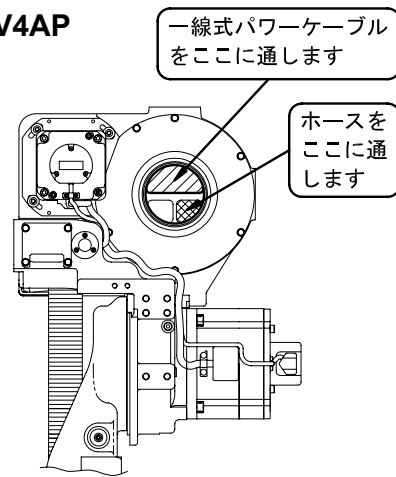

Fig. 3.19 Location to lead hose

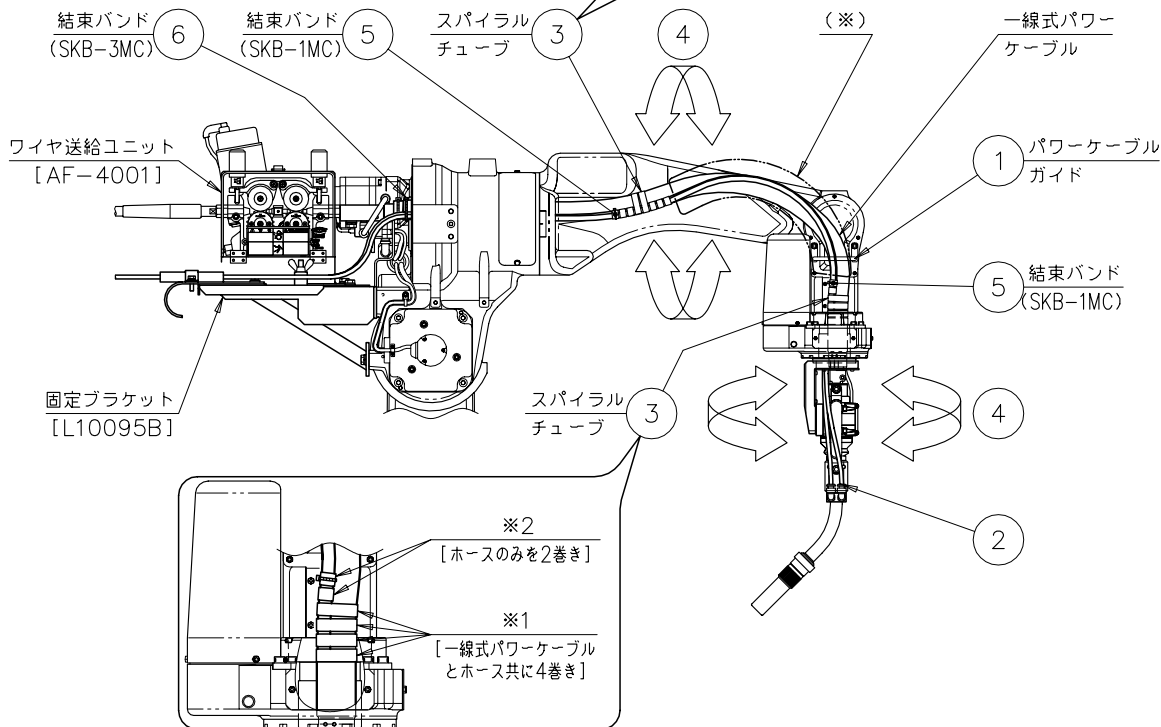
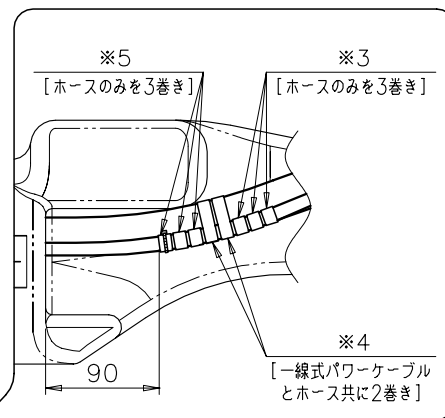

Fig. 3.20 Connection of hose [Almega AX-V4AP]

3.7 Handling Instructions for Torch

- (1) Be sure to install an orifice. Installation of the orifice is essential, which prevents the short circuit likely to happen between the nozzle and torch body, and also avoids turbulence of the shield gas.
- (2) Remove the spatter adhered to the nozzle and contact tip before it gets deposited.
- (3) Be sure to use the DAIHEN genuine tip. Use of a worn-out tip with an enlarged diameter causes conduction defect and wire deflection, which results in unstable Arc and aiming deviation. Therefore, replace the tip accordingly before it gets used up.
- (4) Gas flow shall be 15 l/min or more..
- (5) Clean up the inside of liner (included in the coaxial power cable) and of outlet guide with compressed air or others once in 10 days. Otherwise, deposit of sludge and dust will cause defective wire feeding, which leads to poor welding performance.
- (6) When the wire is stuck at the tip end, the wire will buckle in the liner or be cut in the feed roll. If keeping wire feed performance under such a condition, feeding failure or Arc shortage may occur. To prevent this, remove the wire between the feed roll and tip end first, and then insert a new wire.
- (7) For the teaching program that lets the torch evacuated from the workpiece after welding performance, teach it to pull up the torch obliquely upward so that the shock sensor can work even if the wire sticks on the workpiece.

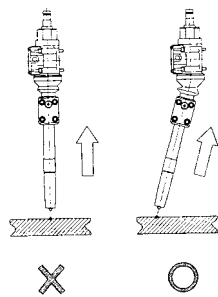

Fig. 3.21 Evacuating direction

- (8) The shock sensor is the mechanism to protect the torch and manipulator in the case of collision between the torch and workpiece, but does not guarantee the accuracy of the torch tip teaching point (torch aiming point) afterward. After the shock sensor has worked, check the aiming point of torch again with the torch gauge.
- (9) When replacing the O-ring of water-cooled torch, take enough care not to hurt the O-ring inside the insulating bush by the screw part of tip body. Blemish made in the O-ring will cause water leaks.

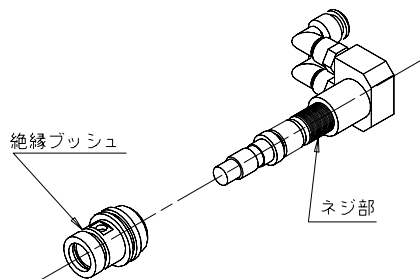

Fig. 3.22 Replacement of O-ring

Coaxial Power Cable for Robot

4.1 Type of Coaxial Power Cables

The coaxial power cable is to lead the wire and shield gas from the wire feeding unit, shock sensor cable, and voltage detection cable (when DL W.P.S used) to the torch. Refer to the table below to choose the coaxial power cable according to the manipulator that you use.

Table 4.1 Type of coaxial power cables

Type	Nominal cable length	Applicable manipulator	Remarks
L-6611	1.1 m	AX(EX)-V6, 16	●
L-6612	1.2 m	DR4000/4200/4300/4400	●
L-6613	1.3 m		●
L-6614	1.4 m	AX(EX)-V6L	●
L-6615	1.5 m	DR4200L/606/610	●
L-6616	1.6 m		●
L-6617	1.7 m		△
L-6618	1.8 m	AX(EX)-S3/H3/P3/R3, DR503SP/503SR	●
L-6619	1.9 m		△
L-6620	2.0 m		△
L-6621	2.1 m	DR3000/3200, AX(EX)-G3	●
L-6625	2.5 m	AX(EX)-S3, DR503S/603	●
L-10110	1.0m	For V4AP exclusive use	●
L-10113	1.25m	For V4LAP exclusive use	●
L-10140	1.0m	For V4AP DL W.P.S exclusive use	●
L-10143	1.25m	For V4LAP DL W.P.S exclusive use	●

● : Standard, △ : Build-to-order

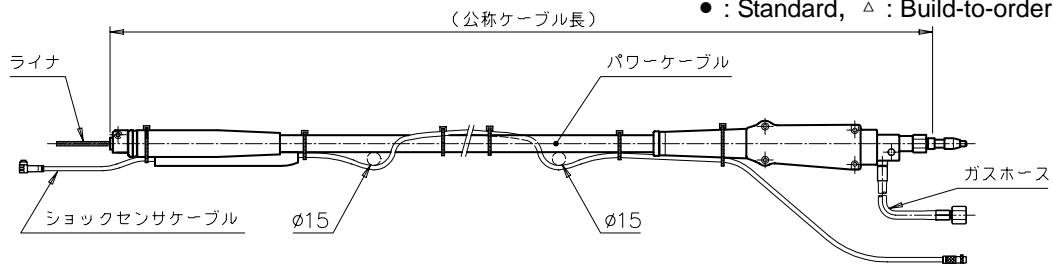

Fig. 4.1 Outline drawing of the coaxial power cable (Other than V4AP)

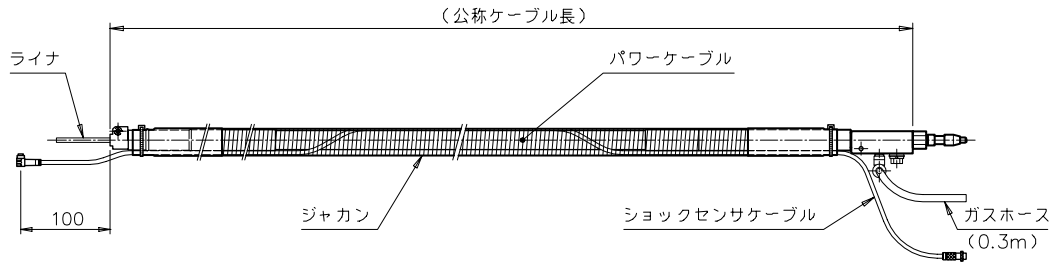

Fig. 4.2 Outline drawing of the coaxial power cable (For V4AP/V4LAP exclusive use)

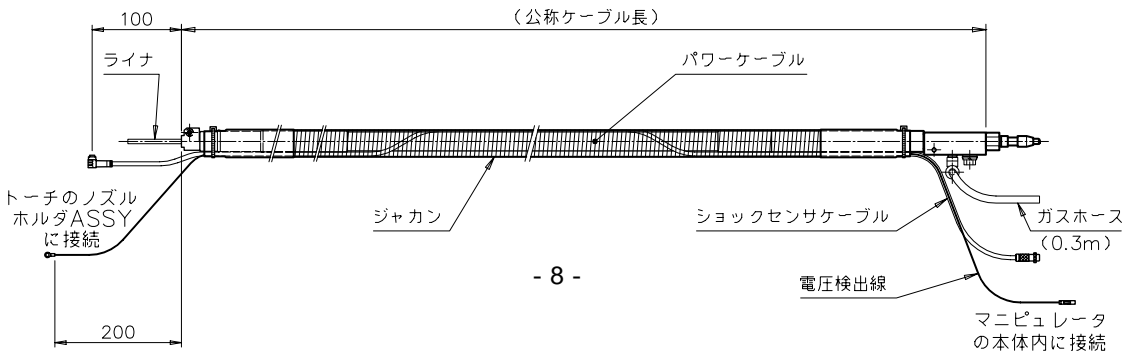

Fig. 4.3 Outline drawing of the coaxial power cable (For V4AP/V4LAP DL W.P.S. exclusive use)

4.2 When Using the DL Welding Power Supply

To use the DL welding power supply with the manipulator other than AX-V4AP/V4LAP, the voltage detection cable is required in addition to the coaxial power cable as described in Table 4.1.

(If you use AX-V4AP/AX-V4LAP, see Table 4.1 and choose a suitable coaxial power cable (for DL W.P.S exclusive use) accordingly.)

4.2.1 Type of voltage detection cables

To use the DL welding power supply with the manipulator other than AX-V4AP/V4LAP, refer to the table below and separately purchase the DL-dedicated voltage detection cable suitable for each manipulator.

Table 4.2 Type of DL W.P.S-dedicated voltage detection cable

No.	Nominal cable length	Applicable coaxial power cable	Applicable manipulator	Remarks
L10140C	1.6 m	L-6611	AX(EX)-V6, 16	
L10140D	1.7 m	L-6612	DR4000/4200/4300/4400	
L10140F	1.9 m	L-6614	AX(EX)-V6L	
L10140G	2.0 m	L-6615	DR4200L, DR606/610	
L10140K	2.3 m	L-6618	AX(EX)-S3/H3/P3/R3, DR503SP/503SR	
L10140N	2.6 m	L-6621	DR3000/3200, AX(EX)-G3	
L10140S	3.0 m	L-6625	AX(EX)-S3, DR503S/603	

Note) Contact us for more of the voltage detection cables not listed in the above.

4.2.2 Assembling the voltage detection cable

A voltage detection cable shall be connected with the coaxial power cable laid along the shock sensor cable. Turn the shock sensor cable and voltage detection cable around the coaxial power cable, and then fix the cables with a binding band, referring to Table 4.3 and Fig.4.4.

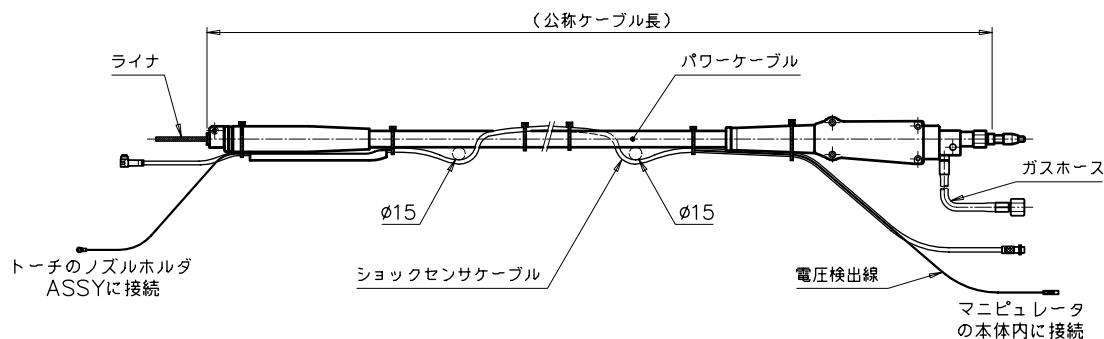

Fig. 4.4 Connection of voltage detection cable (for DL W.P.S)

Table 4.3 Turns of shock sensor cable/voltage detection cable

Coaxial power cable	Turns and slack of φ 15	Remarks
L-6611	2 turns	
L-6612	2 turns	
L-6614	3 turns	
L-6615	3 turns	
L-6618	3 turns	
L-6621	4 turns	
L-6625	4 turns	

IMPORTANT

When connecting the shock sensor cable and voltage detection cable to the coaxial power cable, be sure to follow the specified turns (See Table 4.3) and slack of φ 15 (See Fig.4.4). Shortage of the turns or insufficient slack may lead to the snapping of shock sensor cable and voltage detection cable, resulting in poor welding performance.

4.3 Connection of Coaxial Power Cable

4.3.1 For other than AX-V4AP

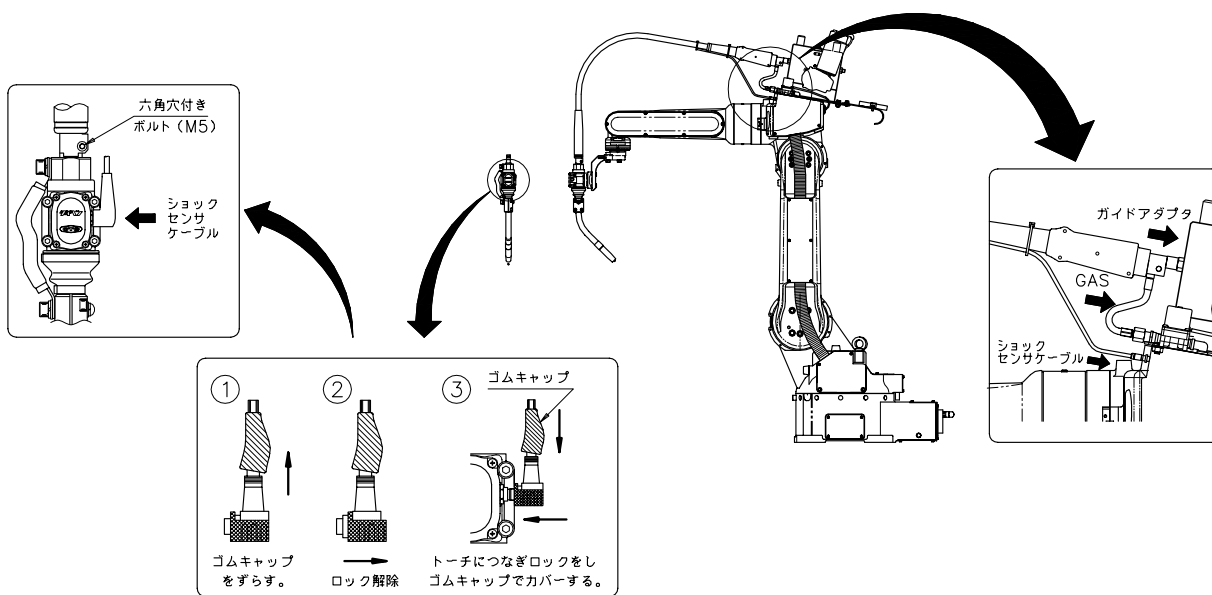

Fig. 4.5 Connection of the coaxial power cable (Except V4AP)

4.3.2 For AX-V4AP

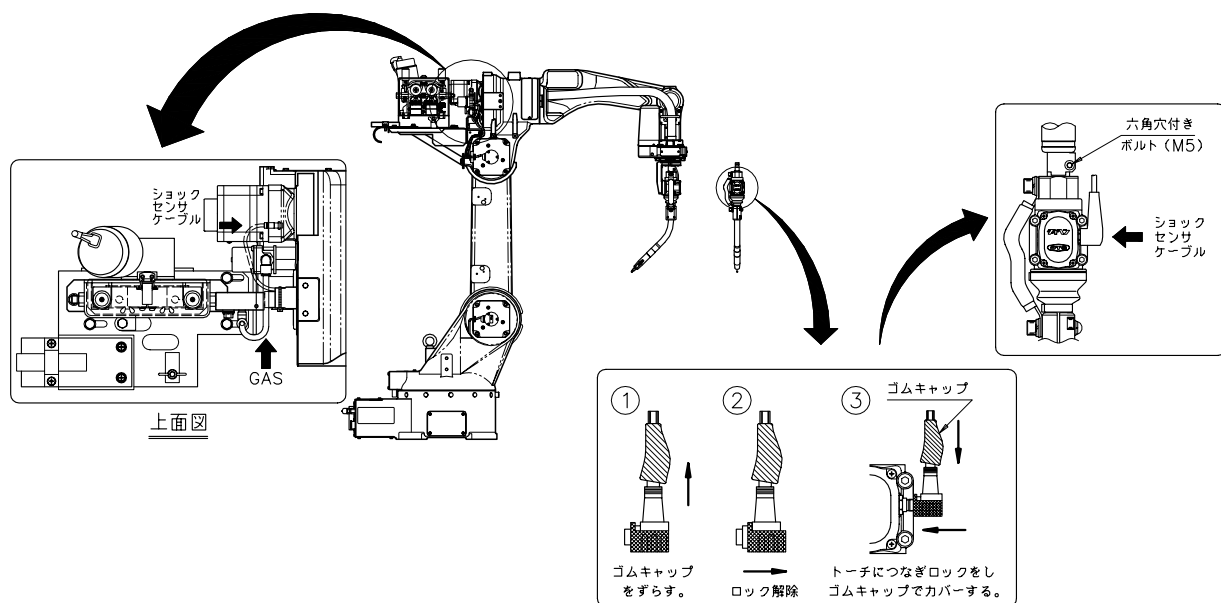

Fig. 4.6 Connection of the coaxial power cable (V4AP)

4.3.3 Adjustment of the coaxial power cable (V4AP)

- (1) Mount a torch, wire feeding unit (fixing bracket), and coaxial power cable.
- (2) Operate the 5th axis to the maximum (soft limit) toward the manipulator's inner side as shown in Fig. 4.7.
- (3) Operate the 6th axis to the maximum (soft limit). (Either in the + or – side.)
- (4) Adjust the fixing bracket in the above posture so that the coaxial power cable does not collide with the cover (see Fig. 4.5).

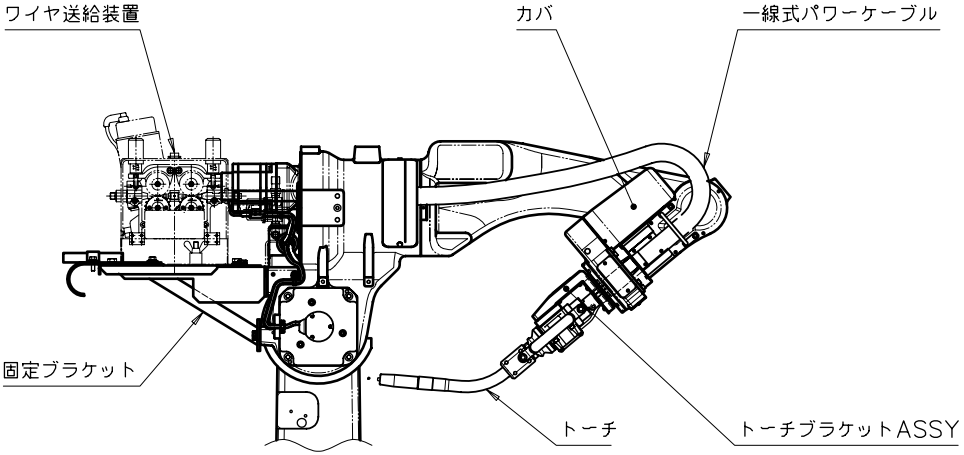

Fig. 4.7 Adjustment of the coaxial power cable

4.4 Cutting the Liner

Cut the liner according to the length of each torch, referring to Fig. 4.8 and Table 4.4.
 Rasp the edge of the liner's cut section to eliminate burrs.
 Also, take enough care not to bend a liner or burr the hole when cutting.

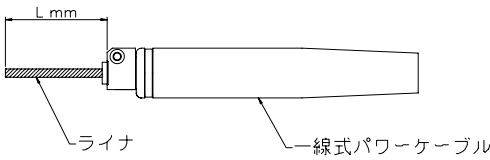

Fig. 4.8 Cutting the liner

Table 4.4 Length of liner (Rough measure)

Torch model	L (mm)
MTX-3531	278
MTXC-3531	345
MTXB-3531	145
MTXCB-3531	145
MTX-5031	266
MTXC-5031	345
MTXB-5031	145
MTXCB-5031	145
MTXW-5031	275
MTXCW-5031	355

5. Setting the Robot Controller

5.1 Checking the Tool Parameter

On delivery of the robot, the data of the welding torch (tool parameter) in use are not set. Then, specify the tool parameter depending on the type of robot and torch as described below.

For the installation posture of torch, see Fig. 5.1 in the next page.

Table 5.1 Tool parameter (for AX series)

V series	Length			Angle			Center of G			Weight	Moment of inertia			Dia.	Fig.
	X	Y	Z	Rx	Ry	Rz	Gx	Gy	Gz	Mass	Ix	Iy	Iz	r	
	[mm]			[deg]			[mm]			[kg]	kgm ²			mm	
MTX-3531	140.0	0.0	385.0	180.0	0.0	0.0	116.0	0.0	107.0	1.9	0.0	0.0	0.0	0.0	①
MTXB-3531										2.0					
MTX-5031										2.0					
MTXB-5031										2.2					
MTXW-5031										2.1					
MTXC-3531	0.0	0.0	400.0	180.0	-45.0	0.0	109.0	0.0	123.0	2.0	0.0	0.0	0.0	0.0	②
MTXCB-3531										2.1					
MTXC-5031										2.3					
MTXCB-5031										2.1					
MTXCW-5031										2.2					

G series	Length			Angle			Center of G			Weight	Moment of inertia			Dia.	Fig.
	X	Y	Z	Rx	Ry	Rz	Gx	Gy	Gz	Mass	Ix	Iy	Iz	r	
	[mm]			[deg]			[mm]			[kg]	kgm ²			mm	
MTX-3531	0.0	-285.0	29.5	-90.0	0.0	0.0	0.0	-51.0	21.0	1.9	0.0	0.0	0.0	0.0	③
MTXB-3531										2.0					
MTX-5031										2.2					
MTXB-5031										2.0					
MTXW-5031										2.2					

V series	Length			Angle			Center of G			Weight	Moment of inertia			Dia.	Fig.
	X	Y	Z	Rx	Ry	Rz	Gx	Gy	Gz	Mass	Ix	Iy	Iz	r	
	[mm]			[deg]			[mm]			[kg]	kgm ²			mm	
MTX-3531	0.0	0.0	350.0	180.0	-45.0	0.0	143.0	0.0	195.0	1.9	0.0	0.0	0.0	0.0	④
MTXB-3531										2.0					
MTX-5031										2.0					
MTXB-5031										2.2					
MTXW-5031										2.2					

V series - AP type	Length			Angle			Center of G			Weight	Moment of inertia			Dia.	Fig.
	X	Y	Z	Rx	Ry	Rz	Gx	Gy	Gz	Mass	Ix	Iy	Iz	r	
	[mm]			[deg]			[mm]			[kg]	kgm ²			mm	
MTXC-3531	-137.0	0.0	390.0	180.0	-45.0	0.0	-13	0.0	117	2.2	0.0	0.0	0.0	0.0	⑤
MTXCB-3531										2.3					
MTXCB-5031										2.4					
MTXC-5031										2.3					
MTXCW-5031			2.4												

Note) The third table from the top is the exclusive use of straight torch (aiming the center of 6th axis). Each weight includes that of torch fixing bracket. The above data are for AX series exclusive use. For the other kinds of manipulators, see the following section.

(There are no tool parameters for the center of gravity, weight, moment of inertia, and diameter.)

Table 5.2 Tool parameter (for DR/EX series)

V series	Length			Angle			Fig.	Length			Angle			Fig.
	1 [mm]	2 [mm]	3 [mm]	4 [deg]	5 [deg]	6 [deg]		1 [mm]	2 [mm]	3 [mm]	4 [deg]	5 [deg]	6 [deg]	
MTX-3531	140.0	0.0	385.0	0.0	0.0	180	①	0.0	0.0	350.0	-45.0	0.0	180.0	④
MTXB-3531														
MTX-5031														
MTXB-5031														
MTXW-5031														
MTXC-3531	0.0	0.0	400.0	-45.0	0.0	180.0	②	Note) The above table is the exclusive use of straight torch (aiming the center of 6 th axis).						
MTXCB-3531														
MTXC-5031														
MTXCB-5031														
MTXCW-5031														

G series	Length			Angle			Fig.
	1 [mm]	2 [mm]	3 [mm]	4 [deg]	5 [deg]	6 [deg]	
MTX-3531	-285.0	0.0	29.0	-90.0	-90.0	180.0	③
MTXB-3531							
MTX-5031							
MTXB-5031							
MTXW-5031							

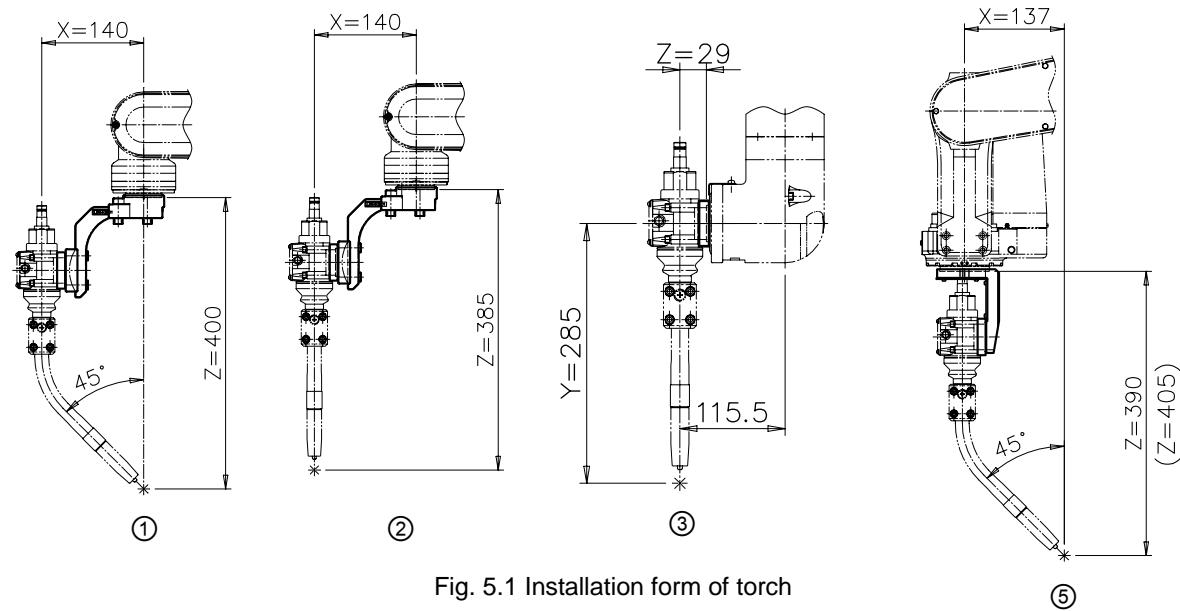
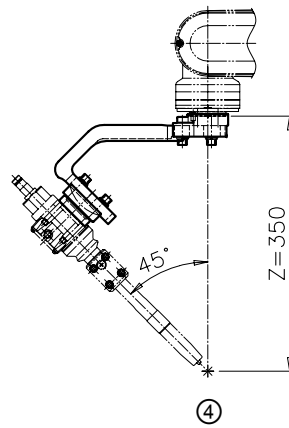

Fig. 5.1 Installation form of torch

Refer to the instruction manual for each manipulator if the data in Table 5.1 and 5.2 have not been set.

Type	Reference instruction manual
DR series	Chapter 4, INSTALLATION & MAINTENANCE (1L5000A-J-*)
EX series	Chapter 7, UTILIZING FEATURES and FUNCTIONS (1L8300G-J-*)

5.2 Checking the Shock Sensor Operation

5.2.1 External force for actuating the shock sensor

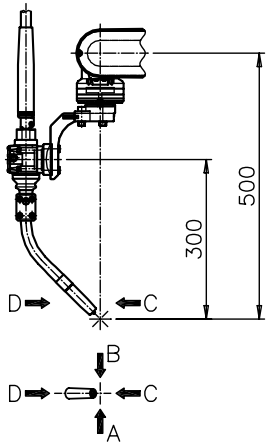

Direction	External force (kg)
A	3.0
B	3.0
C	3.0
D	3.0

The left table shows the rough standard load to actuate the shock sensor when the external force is applied on the torch tip. These values depend on the shape and length of the torch.

Fig. 5.2 Direction of the external force

5.2 Checking the shock sensor operation

- EX/DR manipulator

Check if the message “I 10002-0100 mechanism shock sensor” appears in Teach mode when pressing the torch tip in by hand.

(With EX series manipulator)

The message “I 00201-0101 shock sensor” appears with DR series manipulator.

The message will disappear by unhanding the torch.

Note that the shock sensor cable may be short-circuited if no message appears, while it is possibly disconnected or come down if the message does not disappear.

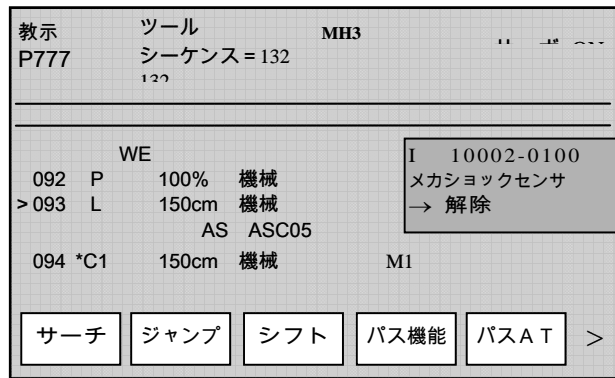

Fig. 5.3 TP screen (EX manipulator)

- AX manipulator

Press the torch tip in by hand and check that the following message appears on [2] Error monitor screen (See Fig. 5.4).

Error category : Emergency stop error
Error code : A4920

The message will disappear by unhanding the torch.

Note that the shock sensor cable may be short-circuited if no message appears, while it is possibly disconnected or come down if the message does not disappear.



Fig. 5.4 TP screen (AX manipulator)

* For details of the error monitor screen, refer to Chapter 8 in the Instruction Manual for Manipulator "BASIC OPERATION (1L8800C-J-*)".

6. Troubleshooting

Phenomena	Possible cause
No arc generation	Contact failure or breaking of welding cable
No smooth wire feeding Unstable welding performance	<ul style="list-style-type: none"> • Shortage of wire pressure in the feed roll • Tip wear • Outlet guide wear • Wire waste powder has deposited in a wire feeding path.
Wire contact on tip	<ul style="list-style-type: none"> • No smooth wire feeding • The hole on the tip became larger. • The distance between tip and workpiece is too short.
Shock sensor cannot be released.	<ul style="list-style-type: none"> • Contact failure or breaking of shock sensor cable • Nozzle is bent. <p>⊗ When a contact accident occurs and the robot operation stops by the shock sensor's detection signal, first investigate the cause of the accident. Pay close attention while operating the robot or restoring the power without known cause. It may be hazardous.</p> <p>To release the contact, see the instruction manual for robot controller "BASIC OPERATIONS" and "TEACHING".</p>
Aim deviation	<p>No orifice is mounted.</p> <p>⊗ If an orifice is not mounted, spatter will be deposited inside to lead conduction between the nozzle and tip body. This will result in anomalous arc discharge and bending in the tip body.</p>
Poor shielding	<ul style="list-style-type: none"> • A designated tip and nozzle are not mounted. • Breaking in the hose (with the air-blow torch)

Replacement Parts for Various Wire Diameters

7.1 Replacement Parts for Various Wire Diameters of Torch

Following parts shall be changed depending on the wire diameter in use.

【Torch related】

- ① Tip

【Coaxial power cable】

- ② Coil liner
- ③ Outlet guide

【Wire feeding unit】

- ④ Feeding roll
- ⑤ Inlet guide

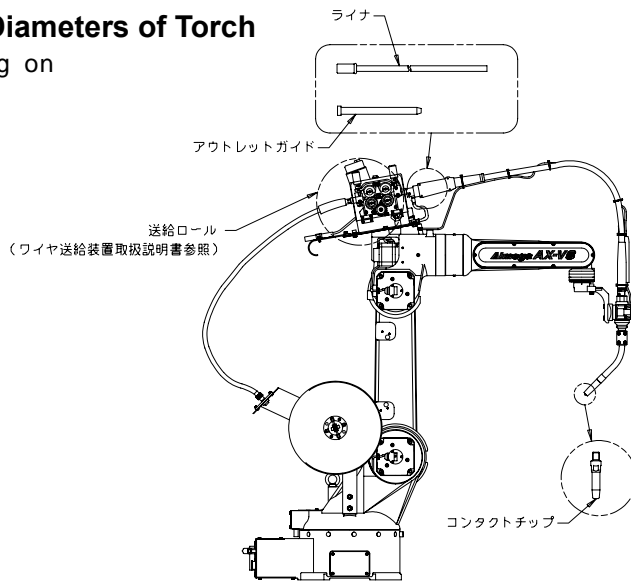

Use the parts suitable for each wire diameter when changing the welding wire. The parts are listed as follows.

Fig.7.1. Replacement parts for various wire diameters of torch

Note) For the feeding roll, see the instruction manual for wire feeding unit.

We provide options for the nozzle. See the Table 7.4 for more details.

- Standard
- △ Option

Table 7.1 Combination of contact tip

Wire dia.	φ 0.8	φ 0.9	φ 1.0	φ 1.2	φ 1.4	φ 1.6
Torch model						
Design No.	L7250B01	L7250B02	L7250B03	L7250B04	L7250B05	L7250B06
Outline drawing						
MTX-3531	△	△	△	●	△	△
MTXC-3531	△	△	△	●	△	△
MTXB-3531	△	△	△	●	△	△
MTXCB-3531	△	△	△	●	△	△
MTX-5031	△	△	△	●	△	△
MTXC-5031	△	△	△	●	△	△
MTXB-5031	△	△	△	●	△	△
MTXCB-5031	△	△	△	●	△	△
MTXW-5031	△	△	△	△	△	●
MTXCW-5031	△	△	△	△	△	●

Table 7.2 Combination of nozzles

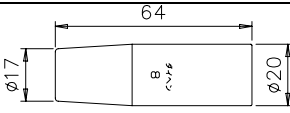
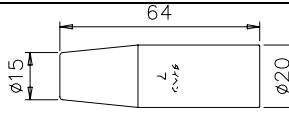
Nozzle dia.	φ 17	φ 15
Torch model		
Design No.	L6380F03	L6380F04
Outline drawing		
MTX-3531	●	△
MTXC-3531	●	△
MTXB-3531	●	△
MTXCB-3531	●	△

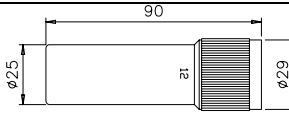
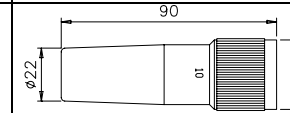
Nozzle dia.	φ 25	φ 19
Torch model		
Design No.	U724E01	U724E02
Outline drawing		
MTXW-5031	●	△
MTXCW-5031	●	△

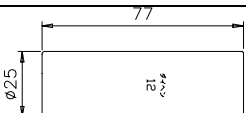
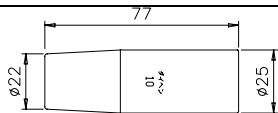
Nozzle dia.	φ 25	φ 22
Torch model		
Design No.	U2774E01	U2774E04
Outline drawing		
MTX-5031	●	△
MTXC-5031	●	△
MTXB-5031	●	△
MTXCB-5031	●	△

7.2 Replacement Parts for Various Wire Diameters of Coaxial Power Cable

Table7.3 Combination of the outlet guide

● Standard
△ Option

Wire dia.	φ 0.8	φ 0.9 ~ 1.2	φ 1.2 ~ 1.6
Torch model			
Design No.	U2770K01	U69B34	U69B35
Outline drawing			
L-6611 / 1.1M	△	●	△
L-6611 / 1.2M	△	●	△
L-6611 / 1.3M	△	●	△
L-6611 / 1.4M	△	●	△
L-6611 / 1.5M	△	●	△
L-6611 / 1.6M	△	●	△
L-6611 / 1.7M	△	●	△
L-6611 / 1.8M	△	●	△
L-6611 / 2.1M	△	●	△
L-6611 / 2.5M	△	●	△
L-10110 / 1.0M	△	●	△
L-10113 / 1.25M	△	●	△
L-10140 / 1.0M	△	●	△
L-10143 / 1.25M	△	●	△

Table7.4 Combination of the liners

● Standard
△ Option

Wire dia.	φ 0.8 ~ 0.9		φ 0.9 ~ 1.2		φ 1.2 ~ 1.6	
Coaxial power cable						
Design No.	L6611D03	U4353G01	L6611D02	U4170H02	L6611D01	U4173G04
Outline drawing						
L-6611 / 1.1M	△		●		△	
L-6611 / 1.2M	△		●		△	
L-6611 / 1.3M	△		●		△	
L-6611 / 1.4M		△		●		△
L-6611 / 1.5M		△		●		△
L-6611 / 1.6M		△		●		△
L-6611 / 1.7M		△		●		△
L-6611 / 1.8M		△		●		△
L-6611 / 2.1M		△		●		△
L-6611 / 2.5M		△		●		△
L-10110 / 1.0M	△		●		△	
L-10113 / 1.25M	△		●		△	

L-10140 / 1.0M	△		●		△	
L-10143 / 1.25M	△		●		△	

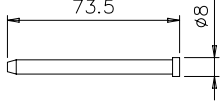
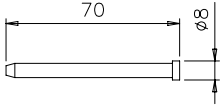
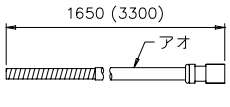
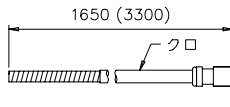
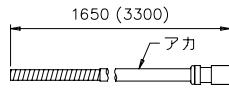
Note) The liner (length: 3300mm) is used when the coaxial power cable is 1.4m or longer.

8. Parts List

For this torch, a shock sensor unit, hood ASSY, nozzle holder, and power-feeding cable are the common parts. A nozzle fitting part is interchangeable for all the models.

- Note) 1. When interchanging the nozzle ASSY, also change the torch gauge, tool parameter and others.
 2. Note that the built-in parts (liner, tip, etc.) may also need to be interchanged.

If the components are worn out or damaged while using this torch, see the following table and contact our sales agent. When ordering, be sure to provide the item name and part No. (or the specification).

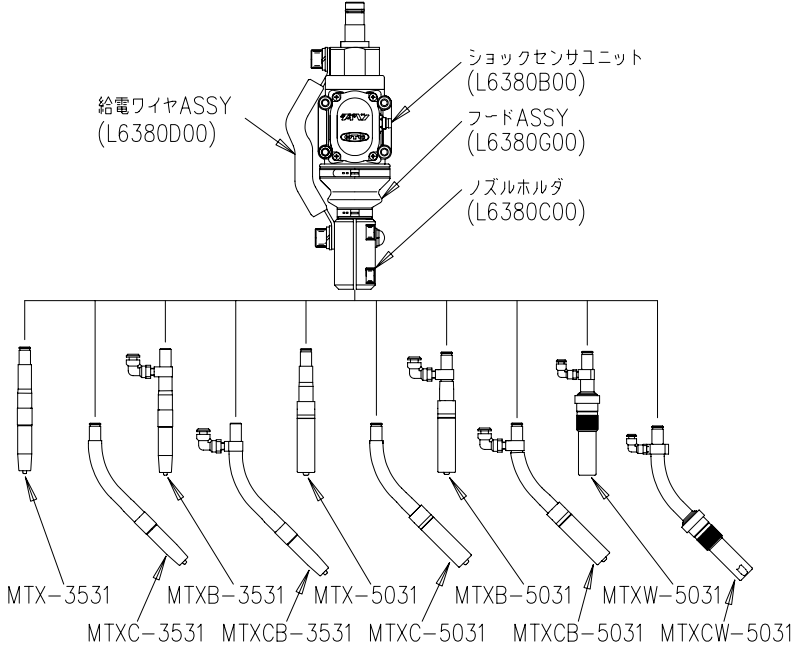

Fig. 8.1 Combination of the shock sensor and nozzle fitting part

Table 8.1 Parts list for MTX-3531

No	Part No.	Item	Qt.	Remarks
1	L6380B00	Shock sensor unit	1	
2	L6380D00	Power-feeding wire ASSY	1	
3	L6380C00	Nozzle holder ASSY	1	
4	L6380E00	Nozzle ASSY	1	
5	L6380G00	Hood ASSY	1	
6	3574-017	" O " - r i n g	1	
7	3574-007	" O " - r i n g	1	
8	L6380F02	T i p b o d y	1	
9	L7250B01	Contact tip (0.8)	(1)	Option
10	L7250B02	Contact tip (0.9)	(1)	Option
11	L7250B03	Contact tip (1.0)	(1)	Option
12	L7250B04	Contact tip (1.2)	1	
13	L7250B05	Contact tip (1.4)	(1)	Option
14	L7250B06	Contact tip (1.6)	(1)	Option
15	U608T00	I n s u l a t o r	1	
16	L6380F01	S p r i n g w a s h e r	1	
17	U2437H01	O r i f i c e	1	
18	L6380F03	N o z z l e (N o . 8)	1	
19	L6380F04	N o z z l e (N o . 7)	(1)	Option

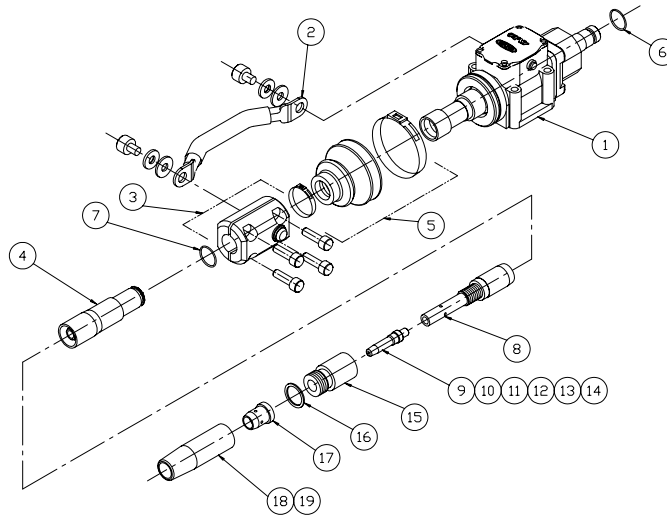

Fig. 8.2 Exploded diagram for MTX-3531

Table 8.2 Parts list for MTXC-3531

No	Part No.	Item	Qt.	Remarks
1	L6380B00	Shock sensor unit	1	
2	L6380D00	Power-feeding wire ASSY	1	
3	L6380C00	Nozzle holder ASSY	1	
4	L6550B00	Nozzle ASSY	1	
5	L6380G00	Hood ASSY	1	
6	3574-017	" O " - r i n g	1	
7	3574-007	" O " - r i n g	1	
8	L6380F02	T i p b o d y	1	
9	L7250B01	Contact tip (0.8)	(1)	Option
10	L7250B02	Contact tip (0.9)	(1)	Option
11	L7250B03	Contact tip (1.0)	(1)	Option
12	L7250B04	Contact tip (1.2)	1	
13	L7250B05	Contact tip (1.4)	(1)	Option
14	L7250B06	Contact tip (1.6)	(1)	Option
15	U608T00	I n s u l a t o r	1	
16	L6380F01	S p r i n g w a s h e r	1	
17	U2437H01	O r i f i c e	1	
18	L6380F03	N o z z l e (N o . 8)	1	
19	L6380F04	N o z z l e (N o . 7)	(1)	Option

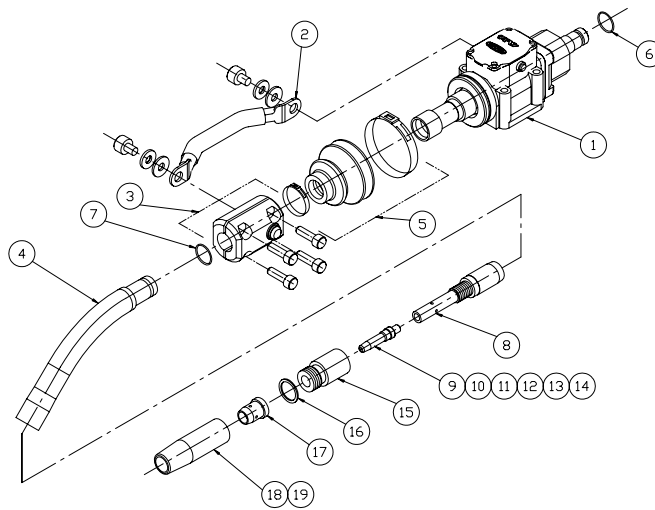

Fig. 8.3 Exploded diagram for MTXC-3531

Table 8.3 Parts list for MTXB-3531

Part No.	Item	Qt.	Remarks
L6380B00	Shock sensor unit	1	
L6380D00	Power-feeding wire ASSY	1	
L6380C00	Nozzle holder ASSY	1	
L6586B00	Nozzle ASSY	1	
L6380G00	Hood ASSY	1	
3574-017	" O " - ring	1	
3574-007	" O " - ring	1	
L6586C01	Tip body	1	
L7250B01	Contact tip (0.8)	(1)	Option
L7250B02	Contact tip (0.9)	(1)	Option
L7250B03	Contact tip (1.0)	(1)	Option
L7250B04	Contact tip (1.2)	1	
L7250B05	Contact tip (1.4)	(1)	Option
L7250B06	Contact tip (1.6)	(1)	Option
U608T00	Insulator	1	
L6380F01	Spring washer	1	
L6380F03	Nozzle (No.8)	1	
L6380F04	Nozzle (No.7)	(1)	Option
U2467G02	O r i f i c e	1	

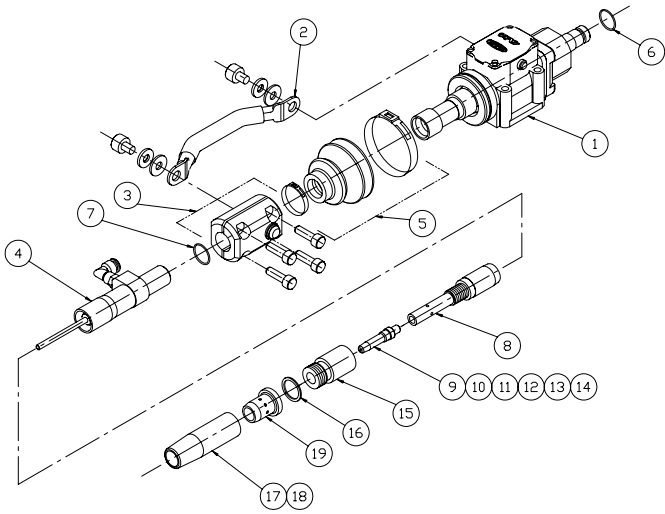

Fig. 8.4 Exploded diagram for MTXB-3531

Table 8.4 Parts list for MTXCB-3531

Part No.	Item	Qt.	Remarks
L6380B00	Shock sensor unit	1	
L6380D00	Power-feeding wire ASSY	1	
L6380C00	Nozzle holder ASSY	1	
L6587D00	Nozzle ASSY	1	
L6380G00	Hood ASSY	1	
3574-017	" O " - ring	1	
3574-007	" O " - ring	1	
L6586C01	Tip body	1	
L7250B01	Contact tip (0.8)	(1)	Option
L7250B02	Contact tip (0.9)	(1)	Option
L7250B03	Contact tip (1.0)	(1)	Option
L7250B04	Contact tip (1.2)	1	
L7250B05	Contact tip (1.4)	(1)	Option
L7250B06	Contact tip (1.6)	(1)	Option
U608T00	Insulator	1	
L6380F01	Spring washer	1	
L6380F03	Nozzle (No.8)	1	
L6380F04	Nozzle (No.7)	(1)	Option
U2467G02	O r i f i c e	1	

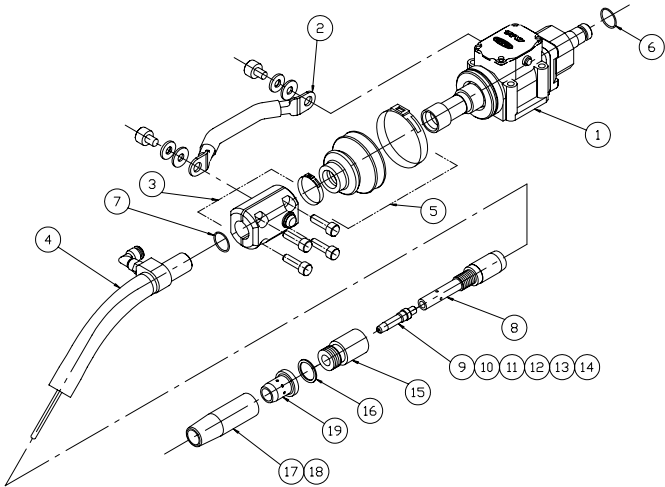

Fig. 8.5 Exploded diagram for MTXCB-3531

Table 8.5 Parts list for MTX-5031

No	Part No.	Item	Qt.	Remarks
1	L6380B00	Shock sensor unit	1	
2	L6380D00	Power-feeding wire ASSY	1	
3	L6380C00	Nozzle holder ASSY	1	
4	L6573B00	Nozzle ASSY	1	
5	L6380G00	Hood ASSY	1	
6	3574-017	" O " - ring	1	
7	3574-007	" O " - ring	1	
8	K1769C01	Tip body	1	
9	U2774F00	Insulator	1	
10	U2774E03	Orifice	1	
11	L6218C01	Tip holder	1	
12	L7250B01	Contact tip (0.8)	(1)	Option
13	L7250B02	Contact tip (0.9)	(1)	Option
14	L7250B03	Contact tip (1.0)	(1)	Option
15	L7250B04	Contact tip (1.2)	1	
16	L7250B05	Contact tip (1.4)	(1)	Option
17	L7250B06	Contact tip (1.6)	(1)	Option
18	U2774E01	Nozzle (No.12)	1	
19	U2774E04	Nozzle (No.10)	(1)	Option
20	L6573C02	Spring washer	1	

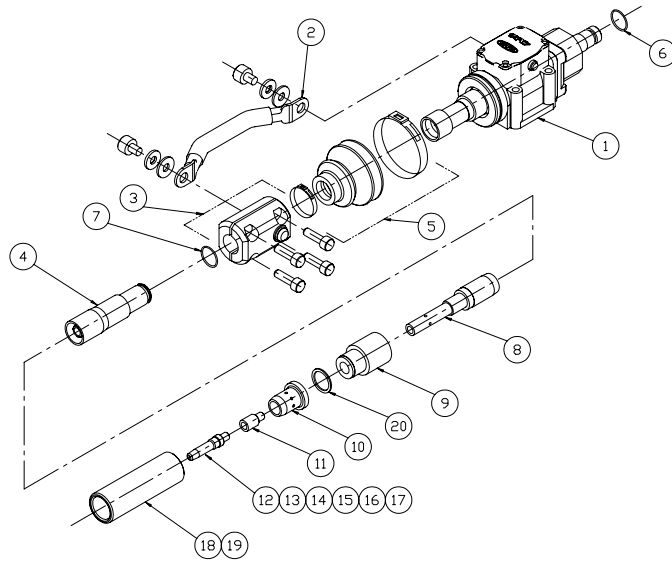

Fig.8.6 Exploded diagram for MTX-5031

Table 8.6 Parts list for MTXC-5031

No	Part No.	Item	Qt.	Remarks
1	L6380B00	Shock sensor unit	1	
2	L6380D00	Power-feeding wire ASSY	1	
3	L6380C00	Nozzle holder ASSY	1	
4	L6574B00	Nozzle ASSY	1	
5	L6380G00	Hood ASSY	1	
6	3574-017	" O " - ring	1	
7	3574-007	" O " - ring	1	
8	K1769C01	Tip body	1	
9	U2774F00	Insulator	1	
10	U2774E03	Orifice	1	
11	L6218C01	Tip holder	1	
12	L7250B01	Contact tip (0.8)	(1)	Option
13	L7250B02	Contact tip (0.9)	(1)	Option
14	L7250B03	Contact tip (1.0)	(1)	Option
15	L7250B04	Contact tip (1.2)	1	
16	L7250B05	Contact tip (1.4)	(1)	Option
17	L7250B06	Contact tip (1.6)	(1)	Option
18	U2774E01	Nozzle (No.12)	1	
19	U2774E04	Nozzle (No.10)	(1)	Option
20	L6573C02	Spring washer	1	

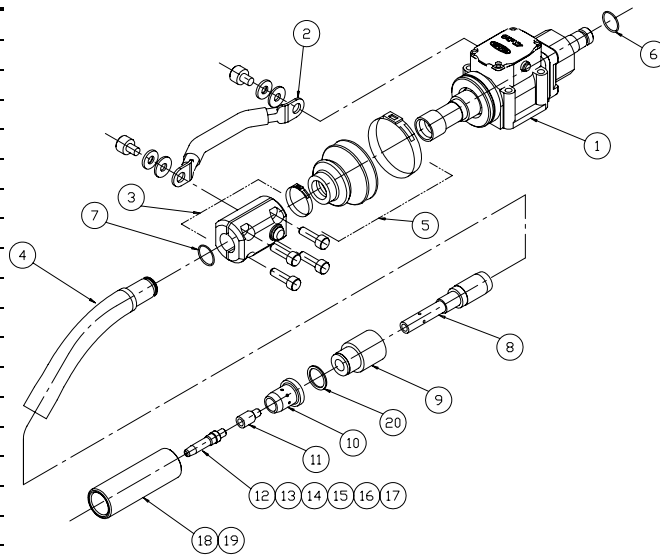

Fig. 8.7 Exploded diagram for MTXC-5031

Table 8.7 Parts list for MTXB-5031

Part No.	Item	Qt.	Remarks
L6380B00	Shock sensor unit	1	
L6380D00	Power-feeding wire ASSY	1	
L6380C00	Nozzle holder ASSY	1	
L7064B00	Nozzle ASSY	1	
L6380G00	Hood ASSY	1	
3574-017	" O " - r i n g	1	
3574-007	" O " - r i n g	1	
L6586C01	T i p b o d y	1	
U2774F00	I n s u l a t o r	1	
U2774E03	O r i f i c e	1	
L6218C01	T i p h o l d e r	1	
L7250B01	Contact tip (0.8)	(1)	Option
L7250B02	Contact tip (0.9)	(1)	Option
L7250B03	Contact tip (1.0)	(1)	Option
L7250B04	Contact tip (1.2)	1	
L7250B05	Contact tip (1.4)	(1)	Option
L7250B06	Contact tip (1.6)	(1)	Option
U2774E01	Nozzle (No.12)	1	
U2774E04	Nozzle (No.10)	(1)	Option
L6573C02	Spring washer	1	

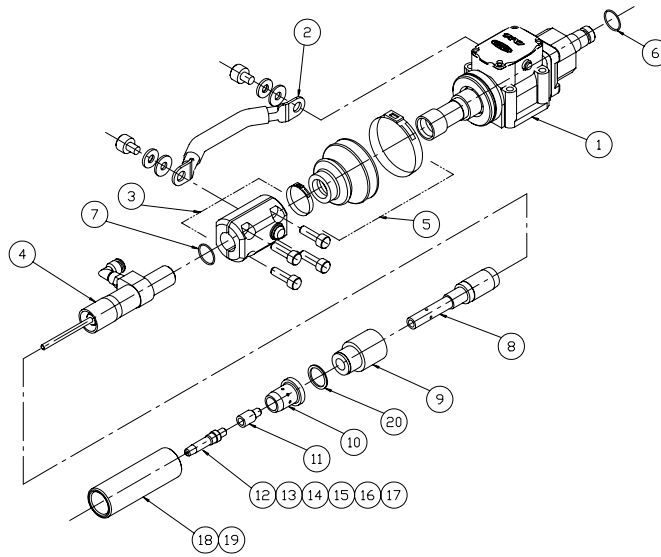

Fig. 8.8 Exploded diagram for MTXB-5031

Table 8.8 Parts list for MTXCB-5031

Part No.	Item	Qt.	Remarks
L6380B00	Shock sensor unit	1	
L6380D00	Power-feeding wire ASSY	1	
L6380C00	Nozzle holder ASSY	1	
L7065B00	Nozzle ASSY	1	
L6380G00	Hood ASSY	1	
3574-017	" O " - r i n g	1	
3574-007	" O " - r i n g	1	
L6586C01	T i p b o d y	1	
U2774F00	I n s u l a t o r	1	
U2774E03	O r i f i c e	1	
L6218C01	T i p h o l d e r	1	
L7250B01	Contact tip (0.8)	(1)	Option
L7250B02	Contact tip (0.9)	(1)	Option
L7250B03	Contact tip (1.0)	(1)	Option
L7250B04	Contact tip (1.2)	1	
L7250B05	Contact tip (1.4)	(1)	Option
L7250B06	Contact tip (1.6)	(1)	Option
U2774E01	Nozzle (No.12)	1	
U2774E04	Nozzle (No.10)	(1)	Option
L6573C02	Spring washer	1	

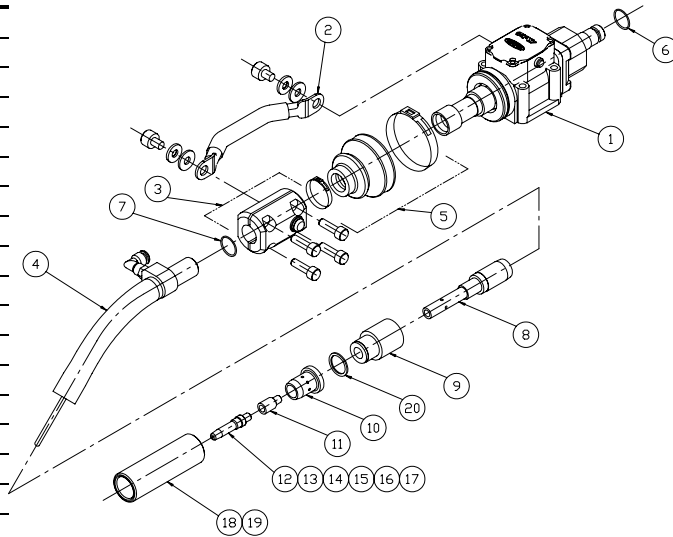

Fig. 8.9 Exploded diagram for MTXCB-5031

Table 8.9 Parts list for MTXW-5031

No	Part No.	Item	Qt.	Remarks
1	L6380B00	Shock sensor unit	1	
2	L6380D00	Power-feeding wire ASSY	1	
3	L6380C00	Nozzle holder ASSY	1	
4	L6571B00	Nozzle ASSY	1	
5	L6380G00	Hood ASSY	1	
6	3574-017	" O " - r i n g	1	
7	3574-007	" O " - r i n g	1	
8	L6571C01	Insulating bush	1	
9	L6571C02	Front body	1	
10	L6571C03	N u t	1	
11	K2585B06	Tip body (1)	1	
12	U2969K03	C a p n u t	1	
13	U3766K01	O r i f i c e	1	
14	3574-006	" O " - r i n g	1	
15	3574-003	" O " - r i n g	1	
16	L7250B01	Contact tip (0.8)	(1)	Option
17	L7250B02	Contact tip (0.9)	(1)	Option
18	L7250B03	Contact tip (1.0)	(1)	Option
19	L7250B04	Contact tip (1.2)	1	
20	L7250B05	Contact tip (1.4)	(1)	Option
21	L7250B06	Contact tip (1.6)	(1)	Option
22	U724E01	Nozzle (No.12)	1	
23	U724E02	Nozzle (No.8)	(1)	Option
24	U2559P05	W r e n c h	1	Standard
25	L6571D00	Cooling hose (1)	2	6m
26	L6571E00	Cooling hose (2)	(2)	8m
27	L6571F00	Cooling hose (3)	(2)	10m
28	3574-002	" O " - r i n g	2	

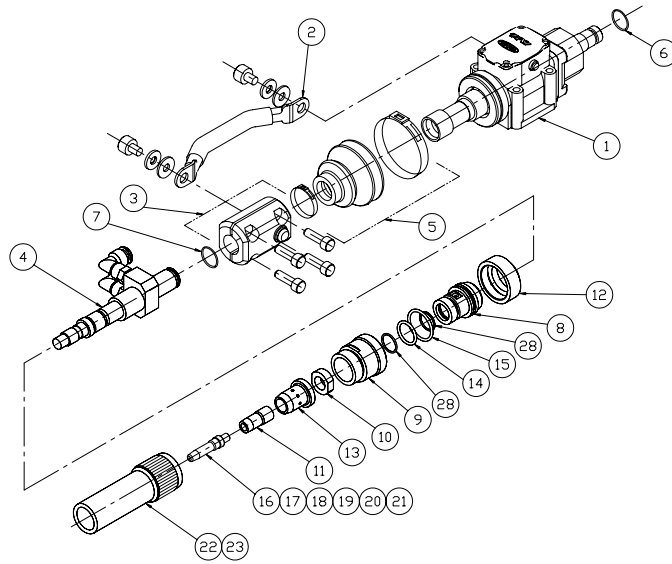

Fig. 8.10 Exploded diagram for MTXW-5031

Table 8.10 Parts list for MTXCW-5031

No	Part No.	Item	Qt.	Remarks
1	L6380B00	Shock sensor unit	1	
2	L6380D00	Power-feeding wire ASSY	1	
3	L6380C00	Nozzle holder ASSY	1	
4	L6572B00	Nozzle ASSY	1	
5	L6380G00	Hood ASSY	1	
6	3574-017	" O " - r i n g	1	
7	3574-007	" O " - r i n g	1	
8	L6571C01	Insulating bush	1	
9	L6571C02	Front body	1	
10	L6571C03	N u t	1	
11	K2585B06	Tip body (1)	1	
12	U2969K03	C a p n u t	1	
13	U3766K01	O r i f i c e	1	
14	3574-006	" O " - r i n g	1	
15	3574-003	" O " - r i n g	1	
16	L7250B01	Contact tip (0.8)	(1)	Option
17	L7250B02	Contact tip (0.9)	(1)	Option
18	L7250B03	Contact tip (1.0)	(1)	Option
19	L7250B04	Contact tip (1.2)	1	
20	L7250B05	Contact tip (1.4)	(1)	Option
21	L7250B06	Contact tip (1.6)	(1)	Option
22	U724E01	Nozzle (No.12)	1	
23	U724E02	Nozzle (No.8)	(1)	Option
24	U2559P05	W r e n c h	1	Standard
25	L6571D00	Cooling hose (1)	2	6m
26	L6571E00	Cooling hose (2)	(2)	8m
27	L6571F00	Cooling hose (3)	(2)	10m
28	3574-002	" O " - r i n g	2	

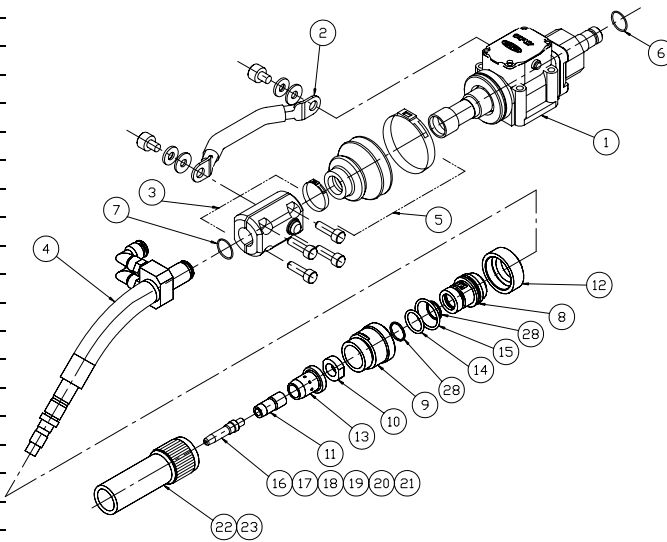

Fig. 8.11 Exploded diagram for MTXCW-5031

Table 8.11 Parts list for the coaxial power cable

No.	Part No.	Item	Qt.	Remarks	No.	Part No.	Item	Qt.	Remarks
	L6580B~K	Power cable ASSY	1		【List of shock sensor cable】				
2	See Fig. below.	Shock sensor cable	1		2	L 6 5 7 7 B	Shock sensor cable (1.1M)	1	
3	L 6 6 1 1 B	Gas hose ASSY	1			L 6 5 7 7 C	Shock sensor cable (1.2M)	1	
4	L6611C01	Power adaptor	1			L 6 5 7 7 D	Shock sensor cable (1.3M)	1	
5	U4167F01	Cable clamp (1)	1			L 6 5 7 7 E	Shock sensor cable (1.4M)	1	
6	U4167F02	Cable clamp (2)	1			L 6 5 7 7 F	Shock sensor cable (1.5M)	1	
7	M 4 × 1 6	Phillips round head screw	1			L 6 5 7 7 G	Shock sensor cable (1.6M)	1	
8	M 4 × 1 6	Hexagon socket nut	1			L 6 5 7 7 H	Shock sensor cable (1.8M)	1	
9	M 4 × 8	Phillips round head screw	1			L 6 5 7 7 J	Shock sensor cable (2.1M)	1	
10	U785C13	Guide adaptor	1			L 6 5 7 7 K	Shock sensor cable (2.5M)	1	
11	U 6 9 B 3 4	Outlet guide (0.9~1.2)	1						
12	U 6 9 B 3 5	Outlet guide (1.2~1.6)	(1)	Option					
13	U2770K01	Outlet guide (0.8)	(1)	Option					
14	L6611D02	Liner (0.9 ~ 1.2)	1	For L-6611~L-6613					
15	U4170H02	Liner (0.9 ~ 1.2)	1	For L-6614~L-6625					
16	L6611D01	Liner (1.2 ~ 1.6)	(1)	For L-6611~L-6613					
17	U4173G04	Liner (1.2 ~ 1.6)	(1)	For L-6614~L-6625					
18	L6611D03	Liner (0.8 ~ 0.9)	(1)	For L-6611~L-6613					
19	U4353G01	Liner (0.8 ~ 0.9)	(1)	For L-6614~L-6625					
20	L6577B01	C a p	1						

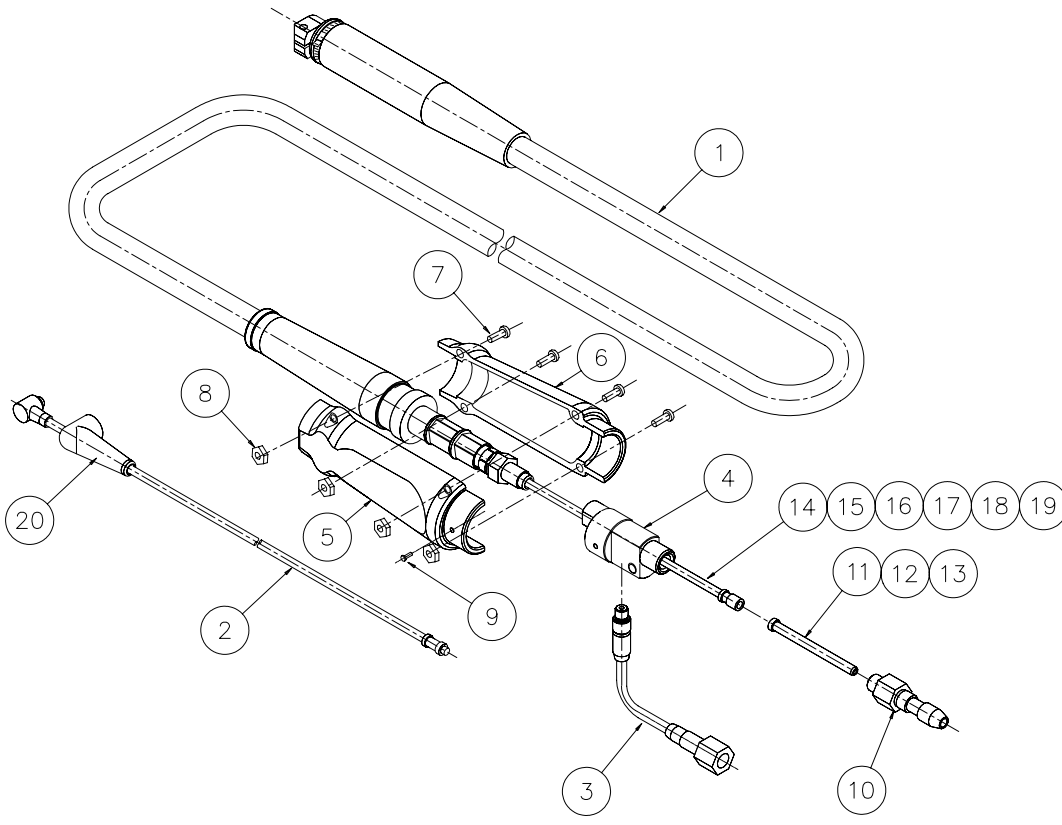

Fig.8.12 Exploded diagram for the coaxial power cable

Table 8.12 Parts list for the coaxial power cable (For AX-V4AP/V4LAP exclusive)

No.	Part No.	Item	Qt.	Remarks	No.	Part No.	Item	Qt.	Remarks
	See the right table	Power cable ASSY	1st		11	See the table below.	Shock sensor cable	1st	
1	3574-017	"O" - ring	(2)		11-1	L6577B01	Cap	(1)	
2	L10110C	Connection ASSY	1st		【List of power cable ASSY】				
1	L10110C01	Connection	(1)		1	L10110B	Power cable ASSY	1st	For V4AP
2	KQ2L08-01S	Elbow	(1)			L10113B	Power cable ASSY	1st	For V4LAP
3	TE-8-AF-BK	Spatter tube	(0.3m)	Manufactured by SMC	【List of shock sensor cable】				
4	M8×12	Hexagon head screw	(1)	Manufactured by CHIYODA	11	L6577B	Shock sensor cable	1st	For V4AP
5	M8	Washer	(1)	With spring washer		L6577D	Shock sensor cable	1st	For V4LAP
6	M5×14	Hexagon socket head bolt	(1)		【For the maintenance of shock sensor cable】				
7	L10110D	Cable cover ASSY	1st		For V4AP	L10110F	Shock sensor cable	1st	
1	L10110D01	Cable cover	(1)			L6577B	Shock sensor cable	(1)	
2	40×0.5	SUMITUBE F	(0.1m)		For V4LAP	40×0.5	SUMITUBE F	(0.25m)	Divide into; 0.1m + 0.15m
3	40×0.5	SUMITUBE F	(0.15m)			L10113D	Shock sensor cable	1st	
4	U785C13	Guide adaptor	1st		For V4LAP	L6577D	Shock sensor cable	(1)	
5	U69B34	Outlet guide (0.9~1.2)	1st			40×0.5	SUMITUBE F	(0.25m)	Divide into; 0.1m + 0.15m
6	U69B35	Outlet guide (1.2~1.6)	(1)			L10113D	Shock sensor cable	1st	
7	U2770K01	Outlet guide (0.8)	(1)	Option		L6577D	Shock sensor cable	(1)	
8	L6611D02	Liner (0.9 ~ 1.2)	1st	Option		40×0.5	SUMITUBE F	(0.25m)	Divide into; 0.1m + 0.15m
9	L6611D01	Liner(1.2 ~ 1.6)	(1)						
10	L6611D03	Liner(0.8 ~ 0.9)	(1)						

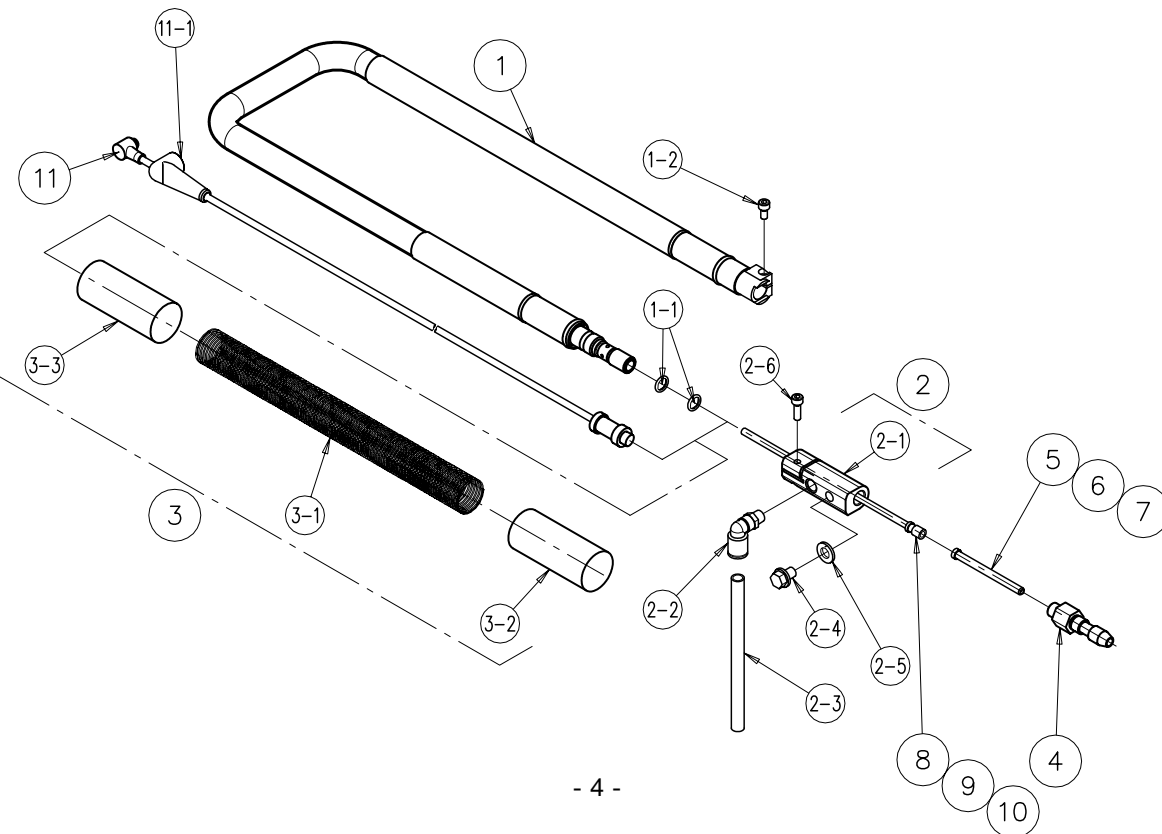

Fig. 8.13 Exploded diagram for the coaxial power cable (For AX-V4AP exclusive)

Table 8.14 Parts list for the coaxial power cable (For AX-V4AP/V4LAP exclusive [DL W.P.S])

No	Part No.	Item	Qt.	Remarks	No	Part No.	Item	Qt.	Remarks
	See the right table	Power cable ASSY	1st		【List of power cable ASSY】				
1	3574-017	"O" - ring	(2)		1	L 1 0 1 1 0 B	Power cable ASSY	1st	For V4AP
2	L 1 0 1 1 0 C	Connection ASSY	1st			L 1 0 1 1 3 B	Power cable ASSY	1st	For V4LAP
1	L10110C01	Connection	(1)		【List of shock sensor cable】				
2	KQ2L08-01S	E l b o w	(1)	From SMC	11	L 6 5 7 7 B	Shock sensor cable	1st	For V4AP
3	TE-8-AF-BK	Spatter tube	(0.3m)	From CHIYODA		L 6 5 7 7 D	Shock sensor cable	1st	For V4LAP
4	M 8 × 1 2	Hexagon head s c r e w	(1)	With spring washer	【List of voltage detection cable】				
5	M 8	W a s h e r	(1)		12	L 1 0 1 4 0 C	Voltage detection cable	1st	For V4AP
6	M 5 × 1 4	Hexagon socket head bolt	(1)			L 1 0 1 4 3 B	Voltage detection cable	1st	For V4LAP
3	L 1 0 1 1 0 D	Cable cover ASSY	1st		【For the maintenance of shock sensor cable】				
1	L10110D01	Cable cover	(1)		For V4 AP	L 1 0 1 1 0 F	Shock sensor cable	1st	
2	4 0 × 0 . 5	SUMITUBE F	(0.1m)			L 6 5 7 7 B	Shock sensor cable	(1)	
3	4 0 × 0 . 5	SUMITUBE F	(0.15m)			4 0 × 0 . 5	SUMITUBE F	(0.25m)	
4	U785C13	Guide adaptor	1st		For V4L AP	L 1 0 1 1 3 D	Shock sensor cable	1st	
5	U 6 9 B 3 4	Outlet guide (0.9~1.2)	1st			L 6 5 7 7 D	Shock sensor cable	(1)	
6	U 6 9 B 3 5	Outlet guide (1.2~1.6)	(1)	Option		4 0 × 0 . 5	SUMITUBE F	(0.25m)	
7	U2770K01	Outlet guide (0.8)	(1)	Option	【For the maintenance of voltage detection cable】				
8	L6611D02	Liner (0.9 ~ 1.2)	1st		For V4 AP	L 1 0 1 4 0 C	Voltage detection cable	1st	
9	L6611D01	Liner(1.2 ~ 1.6)	(1)	Option		L 6 5 7 7 B	Shock sensor cable	(1)	
10	L6611D03	Liner(0.8 ~ 0.9)	(1)	Option		4 0 × 0 . 5	SUMITUBE F	(0.25m)	
11	See the right table	Shock sensor cable	1st		For V4L AP	L 1 0 1 4 3 B	Voltage detection cable	1st	
11-1	L6577B01	C a p	(1)			L 6 5 7 7 D	Shock sensor cable	(1)	
12	See the right table	Voltage detection cable	1st			4 0 × 0 . 5	SUMITUBE F	(0.25m)	

Note) Before using the SUMITUBE F [40 * 0.5] (0.25m), cut it into 0.1m and 0.15m.

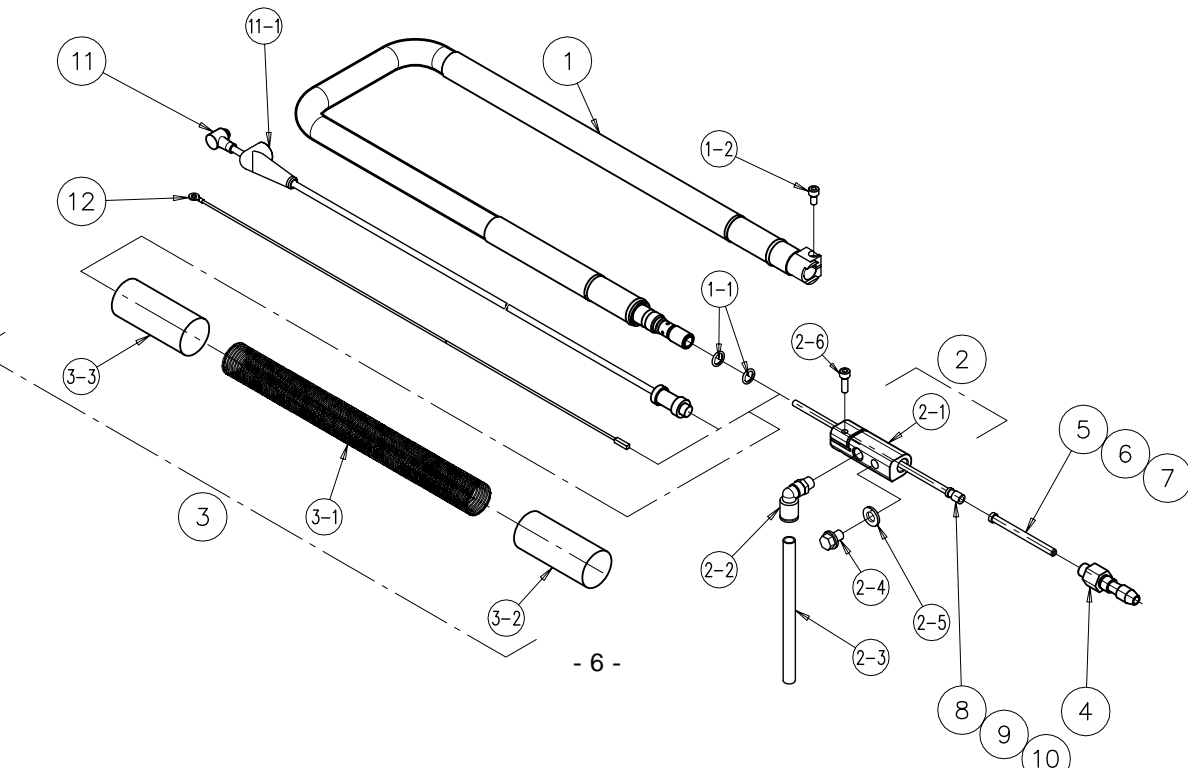

Fig. 8.14 Exploded diagram for the coaxial power cable (For AX-V4AP/DL W.P.S exclusive)