



CAT. NO. A446C

# ADVANCED WELDING & ROBOTIC SYSTEMS

**DP-400/DP-500/DM-350/DM-500 Digital Controlled DC Inverter Arc Welding Machines**

Simple Operation and Perfect Welds from Arc Start to End

## **D** Inverter **SERIES**

Total Solutions from the  
Single Source Provider

**DP-400 and DP-500**  
PULSED MAG - PULSED MIG  
CO<sub>2</sub> - MAG - MIG - FCAW

**DM-350 and DM-500**  
CO<sub>2</sub> - MAG - MIG - FCAW

**CM-741U**  
SEMI-AUTOMATIC  
WIRE FEEDER

Smaller & Lighter  
80 kHz IGBT  
Digital Inverters



# WIRE FEEDERS

## D-SERIES WIRE FEEDERS

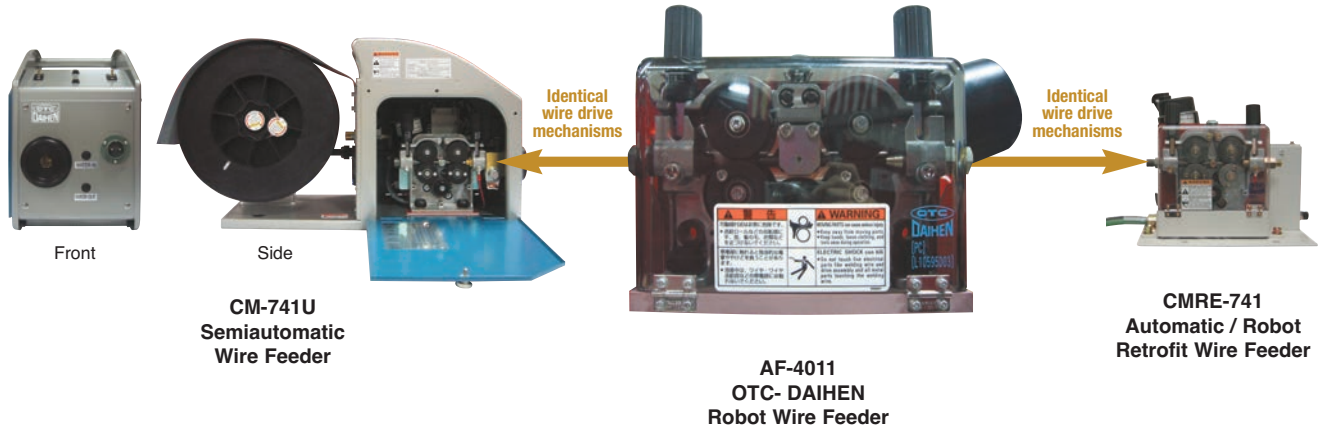

- All wire feeders feature 4-feed rolls for increased drive force for any wire alloy including soft aluminum
- All control circuits are built-in the power source offering incredible durability
- Fully enclosed wire drive mechanism keeps out dirt and grime
- Standard wire cover flap keeps dirt and grime away from the welding wire
- Fully enclosed wire reel cover available as an option
- Suitable for OTC-DAIHEN MIG guns or any other major brand

**OTC-DAIHEN wire feeders come set up for hard wires and air cooled torches as standard features. The following items are available as options...**

- K5735E00 Aluminum Wire Kit
- K5439E00 Fully Enclosed Wire Reel Cover
- K5735000 Water Cooled Hardware Kit

Wire Feeders			
ITEM	CM-741U	CMRE-741	AF-4011
Style	Semiautomatic	Auto & Robot Retrofit	OTC-DAIHEN Robots
Wire Feed Speed	866 in. / min. (22 m/min.)		
Usable Wire Diameters	Mild Steel	inch (.030), .035, .040, .045, (.052), (1/16); mm (0.8), .09, 1.0, 1.2, (1.4), (1.6)	
	Stainless Steel	inch (.030), .035, .040, .045, (.052), (1/16); mm (0.8), .09, 1.0, 1.2, (1.4), (1.6)	
	Hard Alum (AL/MG)	.040, 3/64, 1/16 in. (1.0, 1.2, 1.6 mm)	
	Soft Aluminum	3/64, 1/16 in. (1.2, 1.6 mm)	
Weight	28.6 lb (13 kg)	15.4 lb (7 kg)	9.3 lb (4.2 kg)
External Dimensions (W x D x H)	8.5 x 21.4 x 13.6 inches (215 x 543 x 350 mm)	N/A	N/A

Specifications subject to change without notice.

For more information on  brand products from DAIHEN INC. visit our web site at [daihen-usa.com](http://daihen-usa.com), or send us E-mail at [sales@daihen-usa.com](mailto:sales@daihen-usa.com)



OTC DAIHEN INC.  
(Headquarters)  
1400 Blausler Drive  
Tipp City, OH 45371  
Ph: 937-667-0800  
Fax: 937-667-0885

OTC DAIHEN INC.  
(Charlotte Branch)  
5311 W. T. Harris Blvd., West  
Charlotte, NC 28269

OTC DAIHEN INC.  
(Atlanta Branch)  
2964 Northeast Parkway NW  
Atlanta, GA 30360

OTC DAIHEN INC.  
(Detroit Branch)  
22241 Roethel Drive,  
Suite A  
Novi, MI 48375

# DP-400 / DP-500

## DP-400 / DP-500 ULTRA HIGH QUALITY PULSE & CV GMAW

- DP-400 rated 400A, 50% duty cycle  
DP-500 rated 500A, 60% duty cycle / 350A, 100% duty cycle
- 100 Job memory
- Digital CAN buss interface with OTC DAIHEN robots
- Smaller & lighter 80 kHz IGBT digital inverter
- Three phase automatic input voltage selection
- Factory optimized pulse waveforms
- Adjustable pulse waveform via function key
- Synergic or individual control of voltage and wire feed speed
- Wave Pulse function for TIG like welds on aluminum
- Large 7 segment digital LED numeric display
- Function key for advanced programming
- Cooling fan control: High, Low, and Off
- Very stable pulsed arc as low as 25 amp
- Digital Turbo start and digital burn-back control improves arc starting
- Consistent arc length despite changes in wire extension
- Industrial HMI (Key Pad) operation panel
- Optional pre-set modes available for a variety of wire alloys
- Tool-Free Dinse twist lock connectors for secondary output

### Digital Meters are Easy to Read in Dim Areas

Both Current and Voltage are displayed during welding, with the average current and voltage being displayed after welding is terminated. Additionally, Digital Diagnostics or error codes are displayed to assist troubleshooting.

### Welding Condition Memory

Storage Function (100 conditions)  
Welding Memory Play Back Function of welding conditions can be accessed by one-touch control to repeat or recall weld conditions.

### Function Key

Front Panel Control allows setting of special functions by the operator without having to go inside the Welding Power Source.

### Choice of Welding Modes

Setting of weld conditions such as weld-wire type and wire diameter are easily accomplished by the Touch Panel and reading the LED indications.

### Operators Can Easily Set Conditions

Precise setting of Amps and Volts can be accurately achieved to 1.0 Amp and 0.1 Volt, in addition to other parameters.

### Arc Characteristics

Hard to soft arc characteristics can be chosen for a variety of applications.

### A Variety of Functions

Touch panel control for various user-friendly functions to achieve high quality welding.

### Optional Modes

Software is available for exotic alloys or special applications.



DP-400 Key Pad Operation Panel

### Constant Penetration Control for Hard Wire Applications

Simply switch it on and it keeps the depth of penetration at a constant level even when tip-to-work distance fluctuates as shown. (Not applicable for aluminum.) Conventional GMAW machines typically incorporate only constant voltage (CV) characteristics. When tip-to-work distance fluctuates amperage will fluctuate causing changes in penetration.

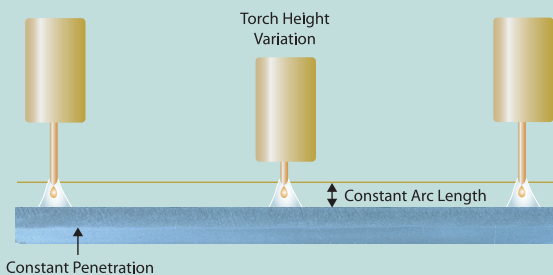

### Newly Developed T-MAC System Supports Multiple Arc Length Characteristic Controls

#### Tailor Made Arc Control

Complete digitalization delivers four (4) types of arc length control for every welding process. Select the welding process on the front panel and the microcomputer automatically selects the ideal arc length control.

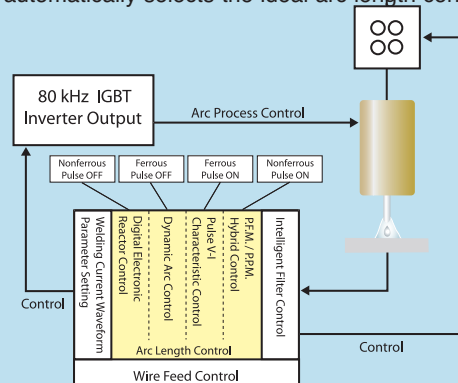





**DM-350**



**DM-500**

DM-350		DM-500	
CV			
Three Phase	Single Phase	Three Phase	
50/60 Hz			
208V / 230V / 460V	230V / 460V	460V	
187-253V, 414-506V	207-253V, 414-506V	414-506V	
16.3	11.6	24.7	
13.8	8.6	22.5	
40.8A / 36.9A / 20.5A	45.2A / 25.3A	31A	
350A	250A	500A	470A
31.5V	26.5V	39V	37.5V
30-350A	30-250A	30-500A	
12-36V	12-31V	12-45V	
59/65/56V	65/56V	87V	
60%		80%	100%
30			
+320°F (+160°C)			
+14 ~ 104°F (-10 ~ +40°C)			
9.8 in x 25.2 in. x 21.6 in. (250 mm x 640 mm x 544 mm)		11.8 in x 24.8 in x 25.8 in (300 mm x 655 mm x 630 mm)	
85.8 lb (39 kg)		123 lb (56 kg)	

# D-SERIES SPECIFICATIONS



**DP-400**



**DP-500**

ITEM	DP-400		DP-500
Mode	Pulse CV (Standard CV Ratings not shown)		
Number of Phases	Three Phase		
Rated Frequency	50/60 Hz		
Rated Input Voltage (Auto Select)	208V / 230V	460V	460V
Input Voltage Range	208/230 ±10%	460 ±10%	460 ±10%
Rated Input kVA	21.4	23.6	23.8
Rated Input kW	19.5	21.5	22.2
Rated Input Current	53.7A	29.6A	29.9A
Rated Output Current	400A		500A
Rated Load Voltage	34V		39.0V
Rated Output Current Range	30-400A		30-500A
Rated Output Voltage Range	12-38V		12-45V
Max. No-Load Voltage	92V		99V
Rated Duty Cycle	50% (60% Standard CV)		100% @ 350A / 60% @ 500A
Max. Program Storage	100		
Temperature Rise	+320°F (+160°C)		
Usable Temperature Range	+14 ~ 104°F (-10 ~ +40°C)		
External Dimensions (W x D x H without handles)	9.8 in. x 25.2 in x 21.4 in. (250 mm x 640 mm x 544 mm)		11.8 in. x 25.7 in. x 23.4 in. (300 mm x 653mm x 595mm)
Weight	99.2 lb (45 kg)		119 lb (54kg)

Specifications subject to change without notice.

DM-350 / DM-500 CV GMAW WITH REDUCED SPATTER

- DM-350 rated 350A, 60% duty cycle  
DM-500 rated 500A, 80% duty cycle / 470A, 100% duty cycle
- 30 program memory
- Digital CAN buss interface with OTC - DAIHEN robots
- Smaller & lighter 80 kHz IGBT digital inverter
- Single & three phase automatic voltage selection
- High speed digital reactor drastically reduces spatter
- Cooling fan: High, Low, and Off
- Industrial HMI (Key Pad) operation panel
- Synergic or individual control of voltage and current (wire feed speed)
- Combination of digital start and digital burn-back control function improves arc starting
- Large 7 segment digital LED numeric display
- Simple push buttons for JOB storage/call-up, and process programming
- Function key for advanced programming
- Consistent arc length despite changes in wire extension
- Tool-Free Dinse twist lock connectors for secondary output



DM-350 Key Pad Operation Panel

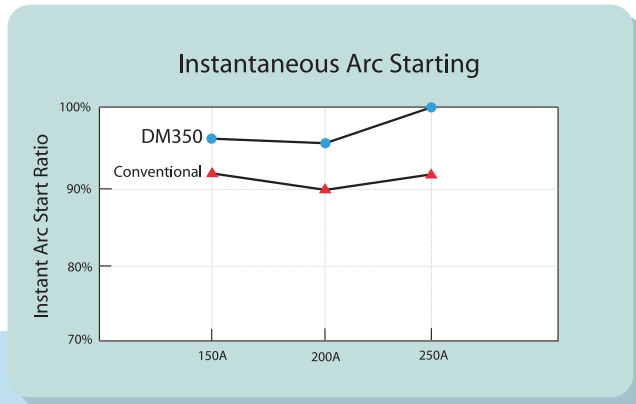

Newly Developed Digital Reactor

Precisely controlled output current and waveform are very effective for reducing spatter.

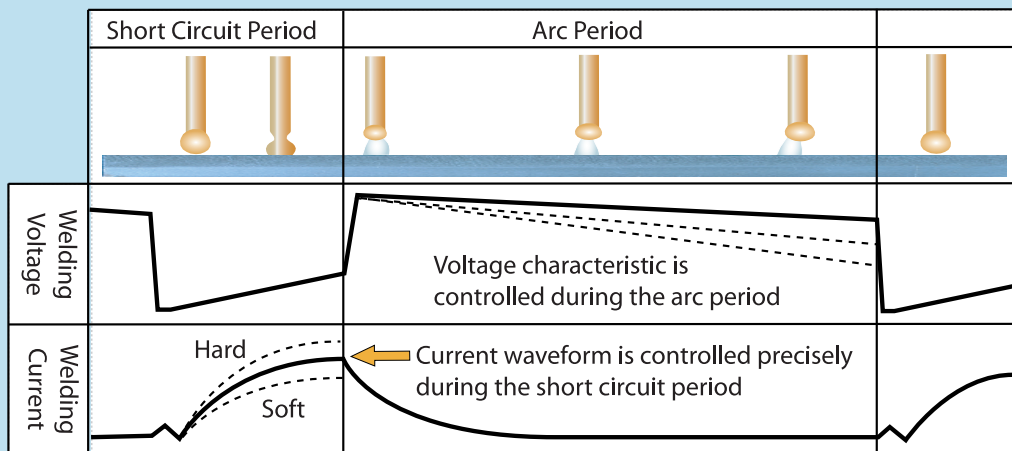

# Advancing the Science of GMAW Applications

## Synchro Short-Pulse Control for Hard Wire Applications

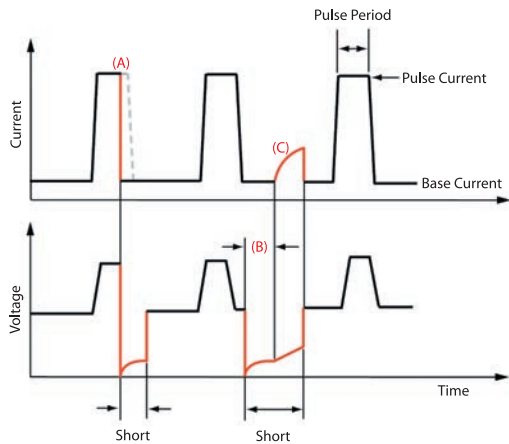

### Synchro Short-Pulse Waveform

- (A) Current control at pulse period short-circuit time
- (B) Instantaneous short-circuit current control
- (C) Automatic digital reactor control

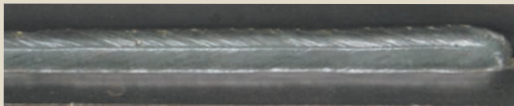

1/8" (3.2 mm) Mild Steel Fillet Weld with .045" (1.2 mm) E70S-3 Mild Steel Wire at 64 in./min.

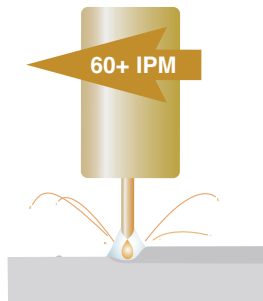

### Synchro Short-Pulse

Allows the use of a very short and rigid arc length enabling very high travel speeds with minimal spatter and consistent droplet transfer

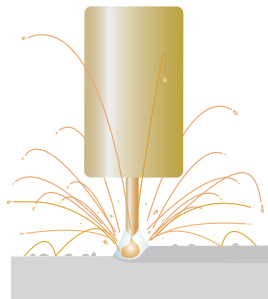

### Conventional Pulsed GMAW

**Reduced arc length**  
Conventional machines cannot control the intrinsic short circuiting spikes that occur with a reduced arc length, thereby creating excessive spatter with irregular droplet size and transfer.

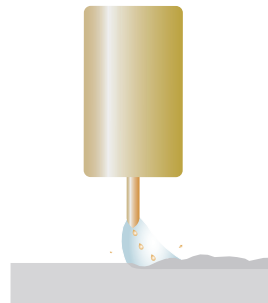

### Increased arc length

The use of a longer arc length minimizes spatter, however the arc becomes softer and tends to drag creating inconsistent bead profiles and penetration

## Wave Pulse for Aluminum

- Wave Pulse utilizes a superimposed low frequency pulse for hard and soft aluminum
- The most obvious benefit is the TIG bead appearance as shown in the weld photo below
- Wave frequency is adjustable from 0.5 to 30 Hz
- Proven to reduce porosity and crack susceptibility



16 gauge (1.6 mm) A5052 Aluminum Plate Butt Welded With 3/64" (1.2 mm) A5356 Aluminum Wire

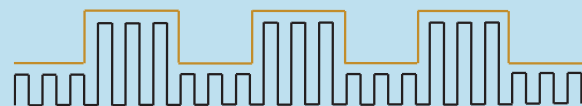

Superimposed low frequency pulse waveform



# Robotic Welding Solutions

## OTC DAIHEN Arc Welding Robot Package

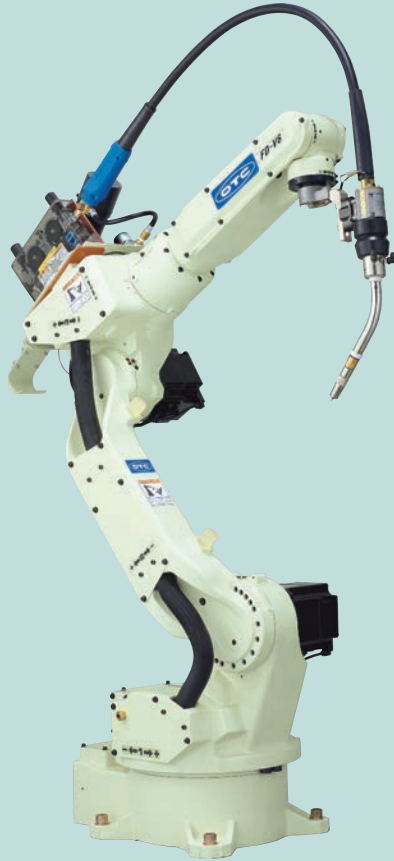

FD Series Robot



AX21 -Series Controller



D-Series Power Source



AF-4011 Wire Feeder

## Existing Robot Retrofit Packages



CMRE-741 Wire Feeder



D-Series Power Source

Get the total robotic welding solution by combining the D-Series with one of our FD Series arc welding robots offering seamless integration and advanced features such as Retract start, Synchro MIG & TIG, Feed Control MIG, networking, arc data monitoring and much more.

The D-Series can also easily adapt to a multitude of other manufacturers robots. Our universal interface and retrofit wire feeder options make combining any D-Series Inverter welding machine a snap.

Call and ask how we can integrate a system for you.

## D SERIES HARDWARE OPTIONS

### Analog Remote Pendant

Takes priority over the HMI key pad on the power source for setting weld current (WFS), arc voltage, and wire inching. 10 ft. cable with optional extensions.



### Digital Remote Pendant

Provides the ability to set all welding parameters from this unit or the front panel of the power source. 10 ft. cable with optional extensions.

(DM-350 pendants shown)