



OWNER'S MANUAL

FOR

PLASMA CUTTING TORCH

MODEL: CT-0351 H999
 CTL-0351 H1000

DO NOT DESTROY

IMPORTANT: Read and understand the entire contents of this manual, with special emphasis on the safety material throughout the manual, before installing, operating, or maintaining this equipment. This equipment and this manual are for use only by persons trained and experienced in the safety operation of cutting equipment. Do not allow untrained persons to install, operate or maintain this equipment. Contact your distributor if you do not fully understand this manual.

DAIHEN Corporation WELDING PRODUCTS DIVISION

June 29, 1999

Upon contact, advise MODEL and MANUAL NO.

CONTENTS

1. SAFETY INFORMATION	2
2. PLASMA ARC CUTTING SAFETY PRECAUTIONS	2
3. ACCESSORIES	8
4. TORCH DRAWING	8
5. NOTICE AT OPERATION	9
6. MAINTENANCE AND TROUBLESHOOTING	12
7. PARTS LIST	16
8. SPECIFICATIONS	17

1. SAFETY INFORMATION

The following safety alert symbols and signal words are used throughout this manual to identify various hazards and special instructions.

 WARNING	WARNING gives information regarding possible personal injury or loss of life.
--	--

 CAUTION	CAUTION refers to minor personal injury or possible equipment damage.
--	--

2. PLASMA ARC CUTTING SAFETY PRECAUTIONS

 WARNING
PLASMA ARC CUTTING can be hazardous.
<p>◆ PROTECT YOURSELF AND OTHERS FROM POSSIBLE SERIOUS INJURY OR DEATH. Be sure to:</p> <ul style="list-style-type: none"> • Keep children away. • Keep pacemaker wearers away until consulting a doctor.
<p>◆ Read and understand the summarized safety information given below and the original principal information that will be found in the PRINCIPAL SAFETY STANDARDS.</p>
<p>◆ Have only trained and experienced persons perform installation, operation, and maintenance of this equipment.</p>
<p>◆ Use only well maintained equipment. Repair or replace damaged parts at once.</p>
PLASMA ARC CUTTING is safe when precautions are taken.



ELECTRIC SHOCK can kill.

Touching live electrical parts can cause fatal shocks or severe burns. The electrode and work circuits are electrically live whenever the output is on. The power line and internal circuits of this equipment are also live when the line disconnect switch is on. When plasma cutting all metal components in the torch and work circuits are electrically live.

1. Do not touch live electrical parts.
2. Wear dry insulating gloves and other body protection that are free of holes.
3. Insulate yourself from work and ground using dry insulating mats or covers.
4. Be sure to turn off the line disconnect switch before installing, changing torch parts or maintaining this equipment.
5. Properly install and ground this equipment according to its Owner's Manual and national, state, and local codes.
6. Ground the base metal to a good electrical earth ground.
7. Keep all panels and covers of this equipment securely in place.
8. Do not use worn, damaged, undersized, or poorly spliced cables.
9. Do not touch electrode and any metal object if POWER switch is ON.
10. Do not wrap cables around your body.
11. Turn off POWER switch when not in use.
12. Keep away from torch tip and pilot arc when trigger is pressed.

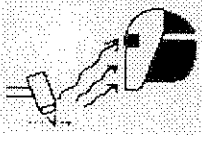

ARC RAYS can burn eyes and skin. NOISE can damage hearing.

Arc rays from the cutting process produce intense heat and strong ultraviolet rays that can burn eyes and skin.

Noise from some plasma arc cutting applications can damage hearing.

1. Wear face shield with a proper shade of filter (See ANSI Z 49.1 listed in PRINCIPAL SAFETY STANDARDS) to protect your face and eyes when cutting or watching a cutter work.
2. Wear approved safety goggles. Side shields recommended.
3. Use protective screens or barriers to protect others from flash and glare: warn others not to look at the arc.
4. Wear protective clothing made from durable, flame-resistant material (wool and leather) and foot protection.
5. Use approved earplugs or earmuffs if noise level is high.

	FUMES AND GASES can be hazardous to your health.
<p>Cutting produces fumes and gases. Breathing these fumes and gases can be hazardous to your health.</p> <ol style="list-style-type: none">1. Keep your head out of the fumes. Do not breathe the fumes.2. Ventilate the area and / or use exhaust at the arc to remove cutting fumes and gases.3. If ventilation is poor, use an approved air-supplied respirator.4. Read the Material Safety Data Sheets (MSDS) and the manufacturer 's instructions on metals to be cut, consumables, coatings, and cleaners.5. Do not cut in locations near degreasing, cleaning, or spraying operations. The heat and rays of the arc can react with vapors to form highly toxic and irritating gases.	

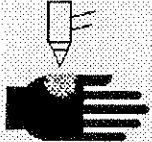
	PLASMA ARC can cause injury
<ol style="list-style-type: none">1. Keep away from the torch tip.2. Do not grip material near the cutting path.3. The pilot arc can cause burns. Keep away from tip when trigger is pressed.4. Wear proper flame-retardant clothing covering all exposed body areas.5. Point torch away from your body and toward work when pressing the torch trigger.6. Turn off the line disconnect switch and POWER switch on the front panel before disassembling torch or changing torch parts.7. Use only torch('s) specified in the Owner's Manual.	

	FLYING SPARKS AND HOT METAL can cause injury.
<p>Chipping and grinding can cause flying metal.</p> <ol style="list-style-type: none">1. Wear approved face shield or safety goggles with side shields.2. Wear proper body protection to protect skin.3. Wear flame-resistant earplugs or earmuffs to prevent sparks from entering ears.	



CYLINDER can explode if damaged.

A shielding gas cylinder contains high-pressure gas. If damaged, a cylinder can explode. Since gas cylinders are normally part of the cutting process, be sure to treat them carefully.

1. Use only correct shielding gas cylinders, regulators, hoses, and fittings designed for the specific application; maintain them in good condition.
2. Protect compressed gas cylinders from excessive heat, mechanical shock, and arcs.
3. Keep the cylinder upright and securely chained to a stationary support or a rack to prevent falling or tipping.
4. Keep cylinders away from any cutting or other electrical circuit.
5. Never touch cylinder with cutting electrode.
6. Read and follow instructions on compressed gas cylinders, associated equipment, and the CGA publication P-1 listed in PRINCIPAL SAFETY STANDARDS.
7. Turn face away from valve outlet when opening cylinder valve.
8. Keep protective cap in place over valve except when gas cylinder is in use or connected for use.

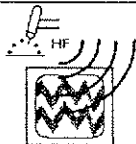

This equipment uses high frequency for arc starting.

High-frequency may enter nearby units as shown below, causing electromagnetic trouble.

- * Input cables, signal cables, telephone cables
- * Radio sets, TV sets
- * Computers and other control equipment
- * Industrial detectors and safety units
- * Pacemakers, hearing-aid sets

For preventing electromagnetic trouble,

1. Make the cable as shortest as possible.
2. Install cables along the floor or the ground as close as possible.
3. Put the base metal side cable together with the torch side cable.
4. Do not use a common base metal ground with other machines.
5. Tightly close all of the doors and covers of this equipment, and secure them.
6. Do not press the torch switch other than when ready to start the arc.
7. When electromagnetic trouble occurs, take the measures shown in this instruction manual until trouble is corrected.
Please contact OTC-DAIHEN, when necessary.
8. Pacemaker wearers must not come near this equipment during operation until consulting your doctor.
Operation of the pacemakers will be affected badly by high frequency.



Rotating parts may cause injuries. Be sure to observe the following.

If hands, fingers, hair or clothes are put near the fan's rotating parts, injuries may occur.

1. Do not use this equipment if the case and the cover are removed.
2. When the case is removed for maintenance/inspection and repair, certified or experienced operators must perform the work. Erect a fence, etc. around the cutting machine to keep others away from it.
3. Do not put hands, fingers, hair or clothes near the rotating fans.

PLASMA ARC CUTTING work areas are potentially hazardous.

FALLING or MOVING machine can cause serious injury.

- ◆ Use both eyebolts, if installed, to lift the cutting power source.
- ◆ Put this equipment solidly on a flat surface.
- ◆ Do not pull this equipment across a floor laid with cables and hoses.

PRINCIPAL SAFETY STANDARDS

Safety in Welding and Cutting, ANSI Standard Z49.1, from American Welding Society.

Safety and Health Standards, OSHA 29 CFR 1910, from Superintendent of Documents, U.S. Government Printing Office.

Recommended Practices for Plasma Arc Cutting, American Welding Society Standard AWS C5.2, from American Welding Society.

Recommended Safe Practices for the Preparation for Welding and Cutting of Containers That Have Held Hazardous Substances, American Welding Society Standard AWS F4.1, from American Welding Society.

National Electrical Code, NFPA Standard 70, from National Fire Protection Association.

Safe Handling of Compressed Gases in Cylinders, CGA Pamphlet P-1, from Compressed Gas Association.





Code for Safety in Welding and Cutting, CSA Standard W117.2, from Canadian Standards Association, Standards Sales.

Safe Practices For Occupation And Educational Eye And Face Protection, ANSI Standard Z87.1, from American National Standards Institute.

Cutting And Welding Processes, NFPA Standard 51B, from National Fire Protection Association.

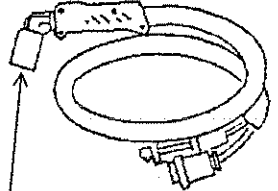
3. ACCESSORIES

● Check the quantity at open



Plasma cutting torch	Accessories											
 <p>Vinyl cup (Take this off when used.)</p>												
			<table border="1"> <thead> <tr> <th>Description</th> <th>Q'ty</th> </tr> </thead> <tbody> <tr> <td>① Shield Cup</td> <td>1</td> </tr> <tr> <td>② Tip</td> <td>3</td> </tr> <tr> <td>③ Electrode</td> <td>3</td> </tr> <tr> <td>④ Wrench</td> <td>1</td> </tr> </tbody> </table>	Description	Q'ty	① Shield Cup	1	② Tip	3	③ Electrode	3	④ Wrench
Description	Q'ty											
① Shield Cup	1											
② Tip	3											
③ Electrode	3											
④ Wrench	1											

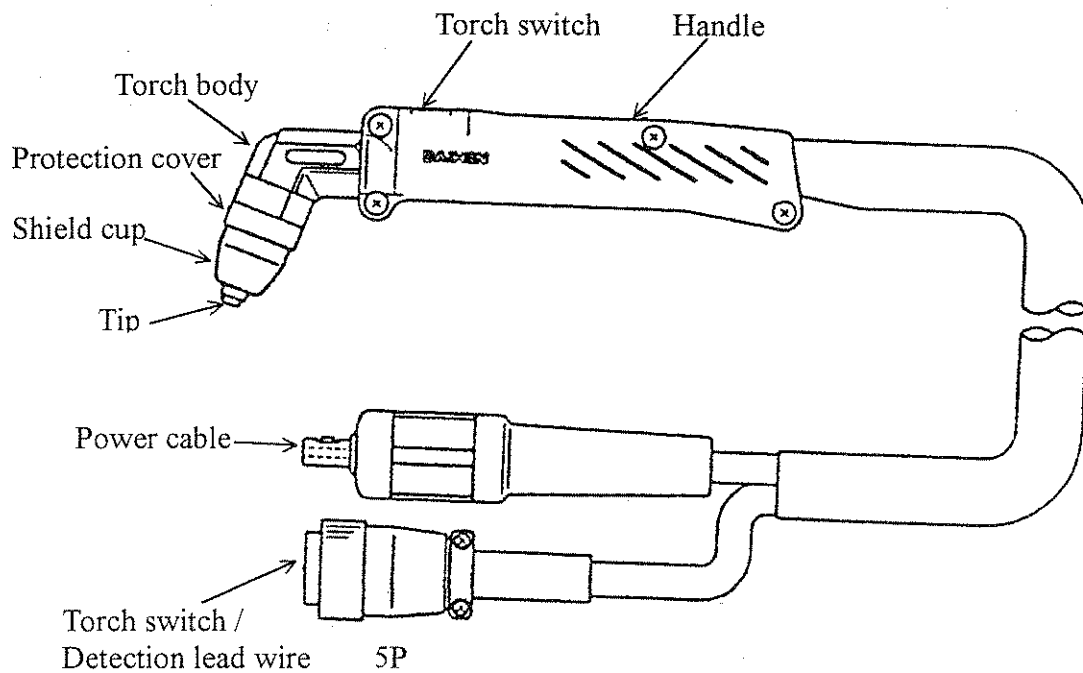

4. TORCH DRAWING



CT(L)-0351 type cutting torch

5. NOTICE AT OPERATION

 WARNING	
	Observe the followings to prevent the electrical shock.
<ul style="list-style-type: none">● Do not touch live electrical parts.● Do not touch tip, when power source is on.● Be sure to turn off the line disconnection switch before checking torch and exchanging parts● Operate the maintenance check periodically, and be sure to troubleshoot and repair immediately.● This cutting torch must be operated by persons who understand contents of this instruction manual and have knowledge and skills for cutting torch safety.	

 CAUTION	
	If you touch plasma arc or pilot arc, you will be burned.
<ul style="list-style-type: none">● Do not point torch in direction of personnel.● If you put torch down during operation, do not put torch switch downward, put torch at unstable place or turn torch switch on carelessly.	

5.1 Rated duty cycle

 CAUTION	
<ul style="list-style-type: none">● Use at the rated duty cycle or less. If exceeding the rated duty cycle, the torch may be deteriorated and burned.● Rated duty cycle : 35A 60%● The duty cycle is expressed in 10 minutes cycles. A duty cycle of 60% is rated with output current for six minutes and off for four minutes, so that the temperature rise inside the torch will not exceed the allowable value.	

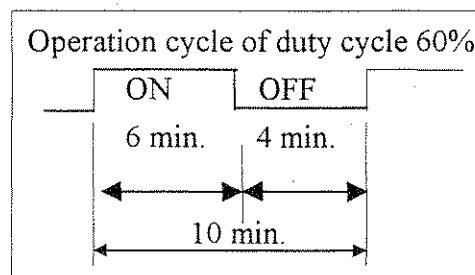

- If exceeding the rated duty cycle, temperature rise of cutting power source and torch exceed the allowable temperature, and it can be cause of burning.

5.2 Precautions for cutting operation

 **CAUTION**
Observe followings when you use torch.

(1) Starting



Do not touch the side of tip to the edge of base metal when starting. Strong arc generates and the hole of tip might be deformed outright.

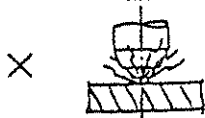

Do not start with touching tip to base metal vertically. Arc generates inside of tip, and tip might be burned.

(2) During cutting



For cutting down, move torch to cutting direction with touching tip to the base metal slightly.

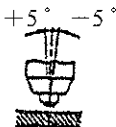

The proper torch angle to base metal should be within $\pm 5^\circ$.
If forward angle is too large, upwash occurs forward of cutting direction.



If torch leans to the right against cutting direction, spatters to the left, and spatters to the right, if torch leans to the left against cutting direction.

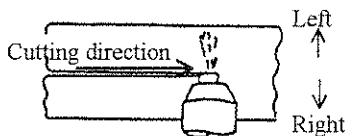

Keep the correct torch angle to prevent spatter.



Plasma arc flows slightly backward with correct cutting speed, so dross can be easily taken off from base metal.

If it is too fast, upwash occurs forward of cutting direction.

(3) Ending

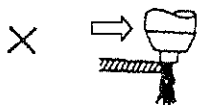

Do not cut down with touching tip to base metal. Strong arc generates, and a hole of tip can be deformed.



At cutting terminal, keep tip away from base metal for 1mm, then cut down.

5.3 Insulating cover

High frequency can leak if the backing plate is a conductive material.

Do not use conductive material.

The insulating cover serves to protect the detective pin. Careless handling of the torch body may cause damage to the insulating cover. If the insulating cover has been removed, high frequency is emitted from the detective pin and may cause damage to the torch body. If the insulating cover is damaged, replace it.

5.4 Clamping the torch for at automatic cutting

- With automatic cutting operation with mounting the torch on a carriage, clamp as follows.

Clamping enable range	Caution				
<p>Angle type torch Clamping recommend zone</p> <table border="1" style="margin-top: 10px; width: 100%; border-collapse: collapse;"> <thead> <tr> <th style="width: 50%;">Description</th> <th style="width: 50%;">Part No.</th> </tr> </thead> <tbody> <tr> <td>Insulating sleeve</td> <td>H705H01</td> </tr> </tbody> </table>	Description	Part No.	Insulating sleeve	H705H01	<p>If clamping recommend zone can not be used, clamp the torch body shown in left drawing. In such a case, insulating sleeve is needed. Refer to the left drawing, and order an insulating sleeve to branch office or nearest agent.</p>
Description	Part No.				
Insulating sleeve	H705H01				

6. MAINTENANCE AND TROUBLESHOOTING

⚠ WARNING	
	Observe followings to prevent electrical shock.
<ul style="list-style-type: none"> ● Do not touch live electrical parts. ● Do not touch tip, when power source is on. ● Be sure to turn off the line disconnection switch before checking torch and exchanging parts ● Operate the maintenance check periodically, and be sure to troubleshoot and repair immediately. ● This cutting torch must be operated by persons who understand contents of this instruction manual and have knowledge and skills for cutting torch safety. 	

⚠ CAUTION	
Observe the followings to prevent burning.	
<ul style="list-style-type: none"> ● When operating, do not touch high temperature parts (tip, shield cup, and base metal just after the operation). ● Use protectors (leather gloves, etc.) when operating. ● Exchanging torch tip parts must be done after cooling down. 	

⚠ CAUTION	
<ul style="list-style-type: none"> ● If parts are damaged, replace with new ones for safety and quality assurance. ● Only use OTC's genuine parts for replacing. 	

6.1 Replacing of shield cup, tip, and electrode

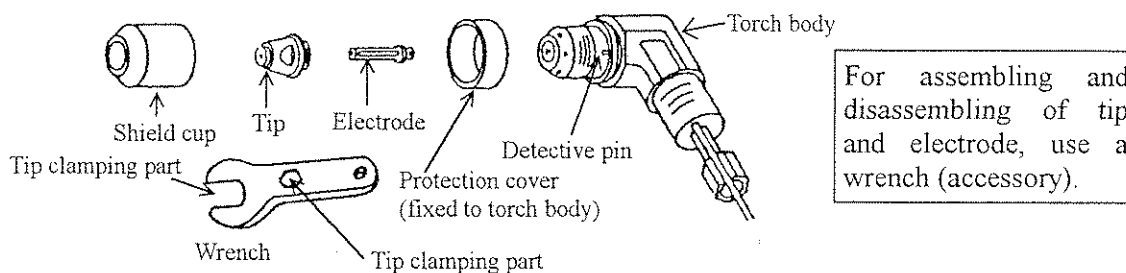

(1) Installation of cup

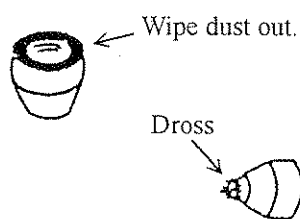

Before installing shield cup to torch body, wipe dusts out by a piece of dry cloth.

Turn cup until tight.





If dross sticks to shield cup, wipe them out as soon as possible, it can cause damage to shield cup.

(2) Replacement of electrode and tip

When the following conditions exist replacement of the electrode and/or tip may be necessary.

Conditions	Check part
<ul style="list-style-type: none"> Starting of pilot arc is impeded, and start is erratic. A loud popping sound is heard at time of starting. Soon after the tip is replaced the hole is deformed. The cut cut is excessively. Tip sticks to the base metal. 	Tip, Electrode Electrode Electrode Tip Tip

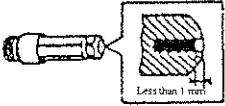
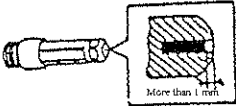

	Check item	Normal	Timing for replacing
Tip	Is the tip hole deformed? 	● The hole is round and not deform. 	● The hole became oval.  ↓ If you keep using this, cutting operation will not work well.
Electrode	Is the tip of electrode consumed? 	● Consumption of the electrode center is less than 1mm.  The sinkage of center is less than 1mm.	● Consumption of the electrode center is more than 1mm.  ↓ If you keep using this, it will be a cause of burn out.

6.2 How to exchange torch body

Disassembly

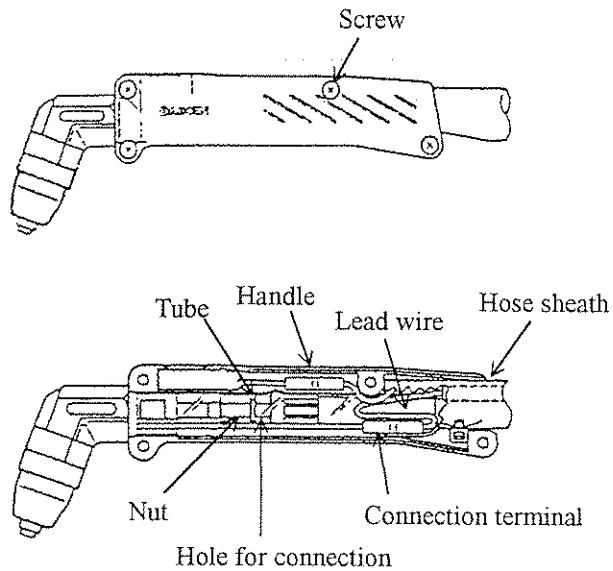

- (1) Unscrew four attaching screws from torch body and open handle.
- (2) Fix torch body, and move hose sheath backward until you see connection terminal of lead wire (about 30mm).
- (3) Cut lead wire at backward of Connection terminal.
- (4) For disassembling of power cable, move tube backward, fix spanner to a hole for spanner and turn nut of power cable to anti-clockwise.

Notices for assembling

1. Since high voltage with high frequency is applied on this torch, be sure to insulate each part.
2. Be sure to connect power cable properly.

Assembly Assembly is in reverse order of disassembly.

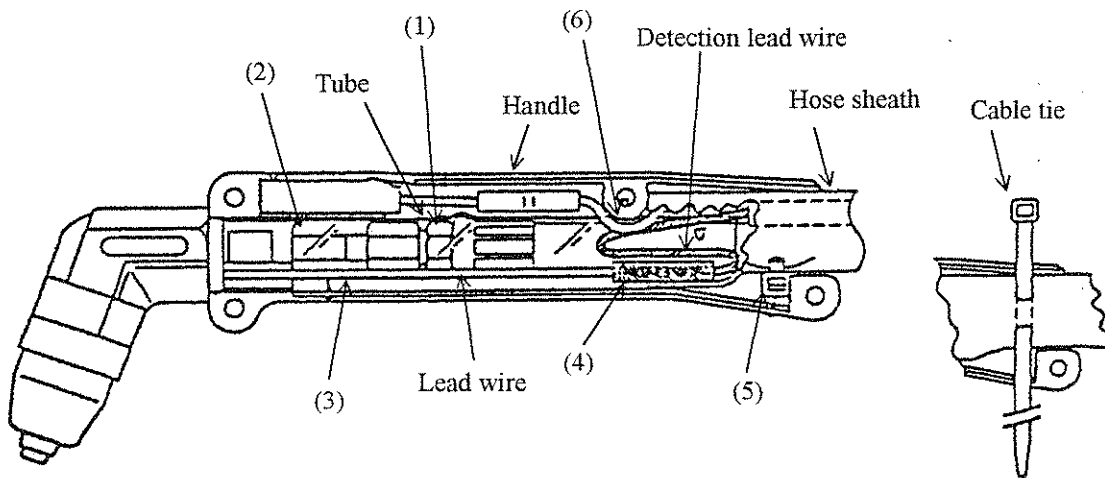

- (1) Connect power cable to torch body.
- (2) Move tube backward to the edge of torch body.
- (3) Tape lead wire together with tube to prevent from pulling into handle.
- (4) Insert black detection lead wire into black butt connect or in torch body and crimp with crimper. Connect and crimp the rest of wires with the same color butt connector.
- (5) Move hose sheath back in position per drawing and tie it with cable tie and put it into under handle. Do not tie power cable and lead wire together.
- (6) Adjust wires to prevent from squeezing into handle, then close and screw handle.

7. PARTS LIST

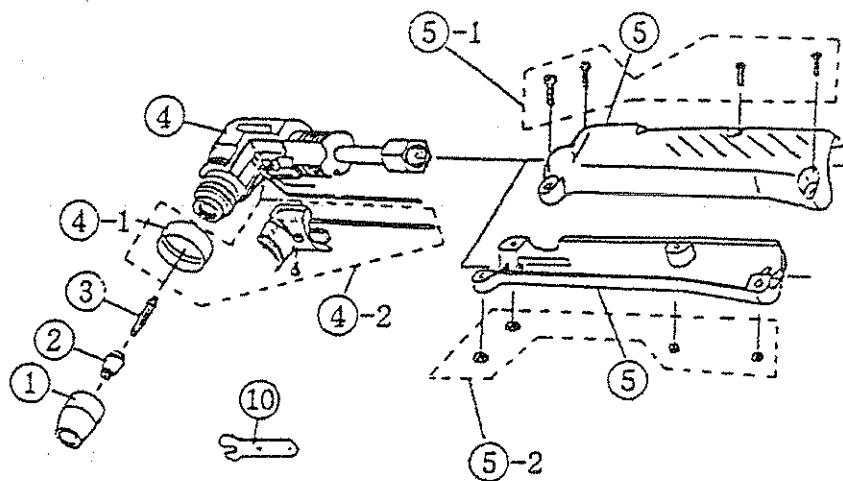

• Standard accessories

No.	Part No.		Description	Q'ty	Spare	Remarks
	CT-0351	CTL-0351				
1	H705F03		Shield cup	1	1	
2	H705F04		Tip	1	3	
3	H705F05		Electrode	1	3	
4	H1041B00		Torch body	1		Includes 4-1 and 4-2.
4-1	H690F01		Protection cover	(1)		
4-2	H999R00		Body cover kit	(1)		
5	H1040C00		Handle	1		Includes 5-1 and 5-2.
5-1	M4×12		Screw	(4)		
5-2	M4		Nut	(4)		
6	H999J00		Torch switch	1		
7	H999F01	H1000F01	Hose sheath	1		
8	H999D00	H1000D00	Power cable assembly	1		
9	H999E00	H1000E00	Control wire assembly	1		Includes 9-1.
9-1	4730-069		Plug socket	(1)		
10	H699G01		Wrench	—	1	

• Optional accessories

	Part No.		Description	Q'ty	Remarks
	CT-0351	CTL-0351			
	0302-001		Circle cutting compass	1	Not be usable with long tip and long electrode.
	0302-010		Easy torch guide	1	
	H705H01		Insulating sleeve	1	
	H999K01		Long tip	1	※ Must be used together
	H999K02		Long electrode	1	

8. SPECIFICATIONS

8.1 Specifications

	CT-0351	CTL-0351
Rated amperage	35A	
Rated duty cycle	60%	
Cooling method	Air-cooled	
Cable length	10m (33ft)	15m (50ft)
Use of gas	Air	
Mass (without cable)	170g (0.37lbs)	

8.2 External view

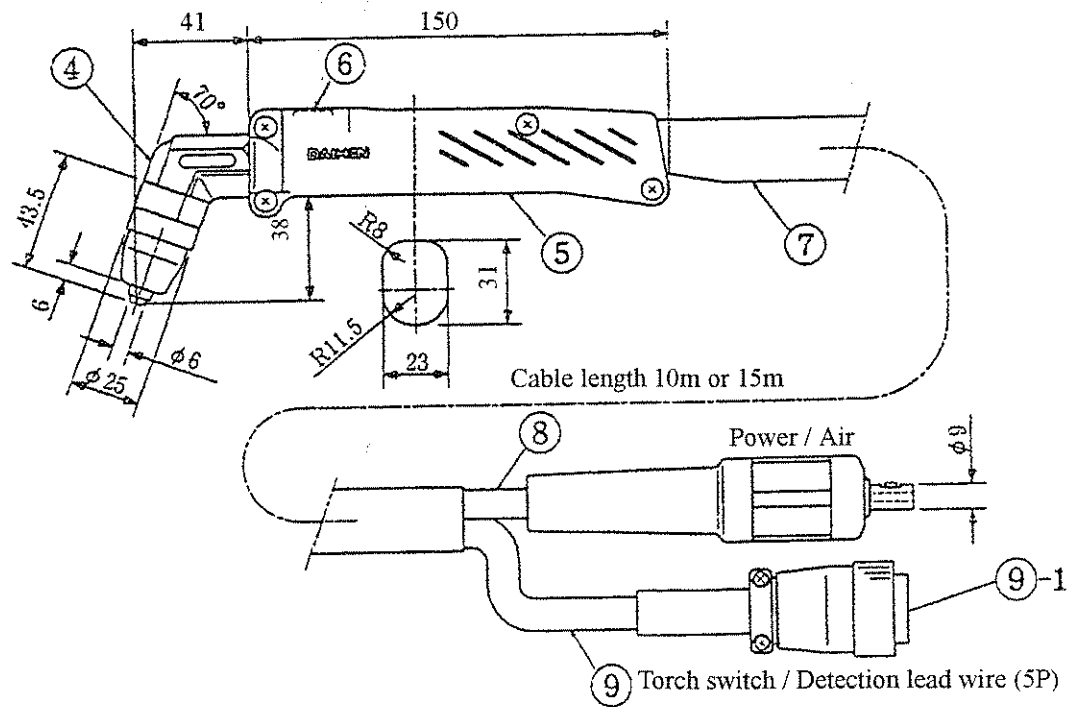

EXTERNAL VIEW

8.3 Combinable cutting power source

VRCM-35

VRCMC-35

