



OWNER'S MANUAL
FOR

MODEL: CMWH-231 U4448

DO NOT DESTROY

IMPORTANT: Read and understand the entire contents of this manual, with special emphasis on the safety material throughout the manual, before installing, operating, or maintaining this equipment. This equipment and this manual are for use only by persons trained and experienced in the safe operation of welding equipment. Do not allow untrained persons to install, operate or maintain this equipment. Contact your distributor if you do not fully understand this manual.

DAIHEN Corporation WELDING PRODUCTS DIVISION

1: February 16, 1998



Upon contact, advise MODEL and MANUAL NO.

CONTENTS

1. SAFETY INFORMATION	2
2. ARC WELDING SAFETY PRECAUTIONS	2
3. CHECKING OF PACKAGE CONTENTS	8
4. EACH DESIGNATION AND OPERATION	8
5. TRANSPORTATION AND INSTALLATION	9
6. CONNECTION	10
7. WELDING PREPARATION	11
8. MAINTENANCE AND REPAIR OF TROUBLES	14
9. PARTS LIST	16
10. SPECIFICATION	20

1. SAFETY INFORMATION

The following safety alert symbols and signal words are used throughout this manual to call attention to and identify different levels of hazard and special instructions.

 WARNING	WARNING gives information regarding possible personal injury or loss of life.
 CAUTION	CAUTION refers to minor personal injury or possible equipment damage.

2. ARC WELDING SAFETY PRECAUTIONS

 WARNING	
ARC WELDING can be hazardous.	
◆	PROTECT YOURSELF AND OTHERS FROM POSSIBLE SERIOUS INJURY OR DEATH. Especially: <ul style="list-style-type: none">• Keep children away.• Pacemaker wearers keep away until consulting a doctor.
◆	Read and understand <ul style="list-style-type: none">• the summarized safety information given below and the original principal information that will be found in the table SAFETY STANDARDS.
◆	Only trained and experienced persons perform installation, operation, and maintenance of this equipment.
◆	Use only well-maintained equipment. Repair or replace damaged parts at once.
ARC WELDING is safe when precautions are taken.	

	<p>ELECTRIC SHOCK can kill.</p>
<p>Touching live electrical parts can cause fatal shocks or severe burns. The electrode and welding circuit is electrically live whenever the output of the welding power source is on. The power line and internal circuit of the welding power source are also live when line disconnect switch is on. In semiautomatic or automatic wire welding, wire reel, drive assembly, and all metal parts touching the welding wire are electrically live.</p> <ol style="list-style-type: none"> 1. Do not touch live electrical parts. 2. Wear dry, hole-free insulating gloves and body protection. 3. Insulate yourself from work and ground using dry insulating mats or covers. 4. Disconnect line disconnect switch before installing, changing torch parts or maintaining this equipment. 5. Properly install and ground this equipment according to its Owner's Manual and national, state, and local codes. 6. Ground the workpiece. 7. Keep all panels and covers of this equipment securely in place. 8. Do not use worn, damaged, undersized, or poorly spliced cables. 9. Do not touch electrode and any metal object if POWER switch is ON. 10. Do not wrap weld cables around your body. 11. Turn off POWER switch when not in use. 	

	<p>ARC RAYS can burn eyes and skin: FLYING SPARKS AND HOT METAL can cause injury. NOISE can damage hearing.</p>
<p>Arc rays from the welding produce intense heat and strong ultraviolet rays that can burn eyes and skin.</p> <p>Noise from some arc welding can damage hearing.</p> <ol style="list-style-type: none"> 1. Wear a face protection with a proper shade of filter (See ANSI Z 49.1 listed in table SAFETY STANDARDS.) to protect your face and eyes when welding or watching. 2. Wear approved safety goggles. 3. Use protective screens or barriers to protect others from flash and glare: warn others not to watch the arc. 4. Wear protective clothing made from durable, flame-resistant material (wool and leather) and foot protection. 5. Use approved ear plugs or ear muffs if noise level is high. 	



WELDING can cause fire and explosion.

Sparks and spatter fly from the welding arc. The flying sparks and hot metal, spatter, hot workpiece, and hot equipment can cause fires and explosion.

1. Protect yourself and others from flying sparks and hot metal.
2. Do not weld where flying sparks can strike flammable material.
3. Remove all flammables within 35ft. (10.7m). If this is not possible, tightly, cover them with approved covers.
 - Be alert that welding sparks and hot metals from welding can easily go through small cracks and openings to adjacent areas.
4. Watch for fire, and keep a fire extinguisher nearby
 - Be aware that welding on a ceiling, floor, bulkhead, or partition can cause fire hidden side.
5. Do not weld on closed containers such as tanks or drums.

Accidental contact of electrode or welding wire to metal object can cause sparks, overheating, or fire.

6. Contact work cable to workpiece as close to the welding area as practical
 - to prevent welding current from traveling long, possibly unknown paths and causing electric shock and fire hazards.
7. Remove stick electrode from holder; cut off wire at contact tip when not in use.
8. Do not use the welding power source for other use than arc welding.
9. Wear oil-free protective garments such as leather gloves, heavy shirt, cuffless trousers, high shoes, and a cap. Loose weld cable connection can cause undesired sparks and excessive heating.
10. Tighten all weld cable connections.

Chipping and grinding cause flying metal. As welds cool, they can throw off slag.

11. Wear approved face shield or safety goggles. Side shield recommended.
12. Wear proper body protection to protect skin.



FUMES AND GASES can be hazardous to your health.

Arc welding may produce fumes and gases hazardous to health.

1. Keep your head out of the fumes; do not breath the fumes.
2. Ventilate the area and / or use exhaust at the arc to remove welding fumes and gases.
3. If ventilation is poor, use an approved air-supplied respirator.
4. Read the Material Safety Data Sheets (MSDSs) and the manufacture's instruction for metals, consumables, coatings, and cleaners.
5. Do not cut in locations near degreasing, cleaning, or spraying operations.

The heat and rays of the arc can react with vapors to form highly toxic and irritating gases.



CYLINDER can explode if damaged.

Shielding gas cylinder contain high pressure gas. If damaged, a cylinder can explode.

1. Use only correct gas cylinders, regulators, hoses, and fittings designed for the specific application; maintain them in good condition.
2. Protect gas cylinder from excessive heat, mechanical shock, and arcs.
3. Keep cylinder in an upright position securely chained to stationary support or rack to prevent falling or tipping.
4. Keep cylinders away from any welding or other electrical circuit.
5. Never touch cylinder with welding electrode.
6. Read and follow instructions on compressed gas cylinders, associate equipment, and CGA publication listed in table SAFETY STANDARDS.

Since gas cylinders are normally part of the welding process, be sure to treat carefully.

7. Turn face away from valve outlet when opening cylinder valve.
8. Keep protective cap in place over valve except when gas cylinder is in use or connected for use.



Rotating parts may cause injuries. Be sure to observe the followings.

If hands, fingers, hair and clothes are put near the rotating parts of wire feeding roll of the feeder, biting may occur, causing injuries.

1. Do not use the welding machine in removing the case and the cover.
2. When the case is removed in maintenance/inspection and repair, certified operators or operators knowing the welding machine well must perform the working. By providing a fence, etc. around the welding machine, do not let other persons come near the welding machine carelessly.
3. Do not put your hands, fingers, hair and cloths near the wire feeding roll rotating.

ARC WELDING WORKSHOP is potentially hazardous.

FALLING, FALLING DOWN and MOVING machine can cause serious injury.

- ◆ Do not lift the welding power source with one eyebolt.
Use two eyebolts to lift it.
- ◆ Put the welding power source and wire feeder solidly on a flat surface.
- ◆ Do not pull the welding power source on floor laid with cables and hoses.
- ◆ Do not put wire feeder on the welding power source.
- ◆ Do not put the welding power source and wire feeder where they will pit or fall.

WELDING WIRE can cause puncture wounds.

- ◆ Do not press gun trigger until instructed to do so.
- ◆ Do not point gun toward any part of the body, other people, or any metal when threading welding wire.

PRINCIPAL SAFETY STANDARDS

Safety in Welding and Cutting, ANSI Standard Z49.1, from American Welding Society, 550 N.W. Lejeune Rd, Miami FL 33126.

Safety and Health Standards, OSHA 29 CFR 1910, from Superintendent of Documents, U.S. Government Printing Office, Washington, D.C.20402.

Recommended Practices for Plasma Arc Cutting, American Welding Society Standard AWS C5.2, from American Welding Society, 550 N.W.Lejeune Rd, Miami, FL 33126.

Recommended Safe Practices for the Preparation for Welding and cutting of containers That Have Held Hazardous Substances, American Welding Society Standard AWS F4.1, from American Welding Society, 550 N.W.Lejeune Rd, Miami, FL 33126.

National Electrical Code, NFPA Standard 70, from National Fire Protection Association, Batterymarch Park, Quickly, MA02269.

Safe Handling of Compressed Gases in Cylinders, CGA Pamphlet P-1, from Compressed Gas Association, 1235 Jefferson Davis Highway, Suite 501, Arlington, VA 22202.

Code for Safety Welding and Cutting, CGA Standard W117.2, from Canadian Standards Association, Standards Sales, 178 Rexdale Boulevard, Rexdale, Ontario, Canada M9W 1R3.

Safe Practices For Occupation And Educational Eye And Face Protection, ANSI Standard Z87.1, from American National Standards Institute, 1430 Broadway, New York, NY10018.

Cutting And Welding Processes, NFPA Standard 51B, from National Fire Protection Association, Batterymarch Park, Quickly, MA 02269.

3. CHECKING OF PACKAGE CONTENTS

- Check of quantity at open the package.
- Wire feeder

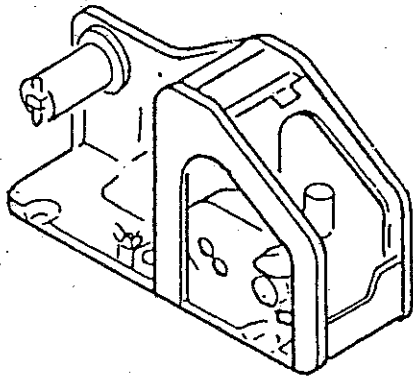

• Standard accessories

No.	Description	Specification	Q'ty
①	Welding cable(grounding)	.093 in ² × 5.25 ft	1
②	Welding cable(torch)	.093 in ² × 5.91 ft	1
③	Plug socket assembly	U3396E00	1

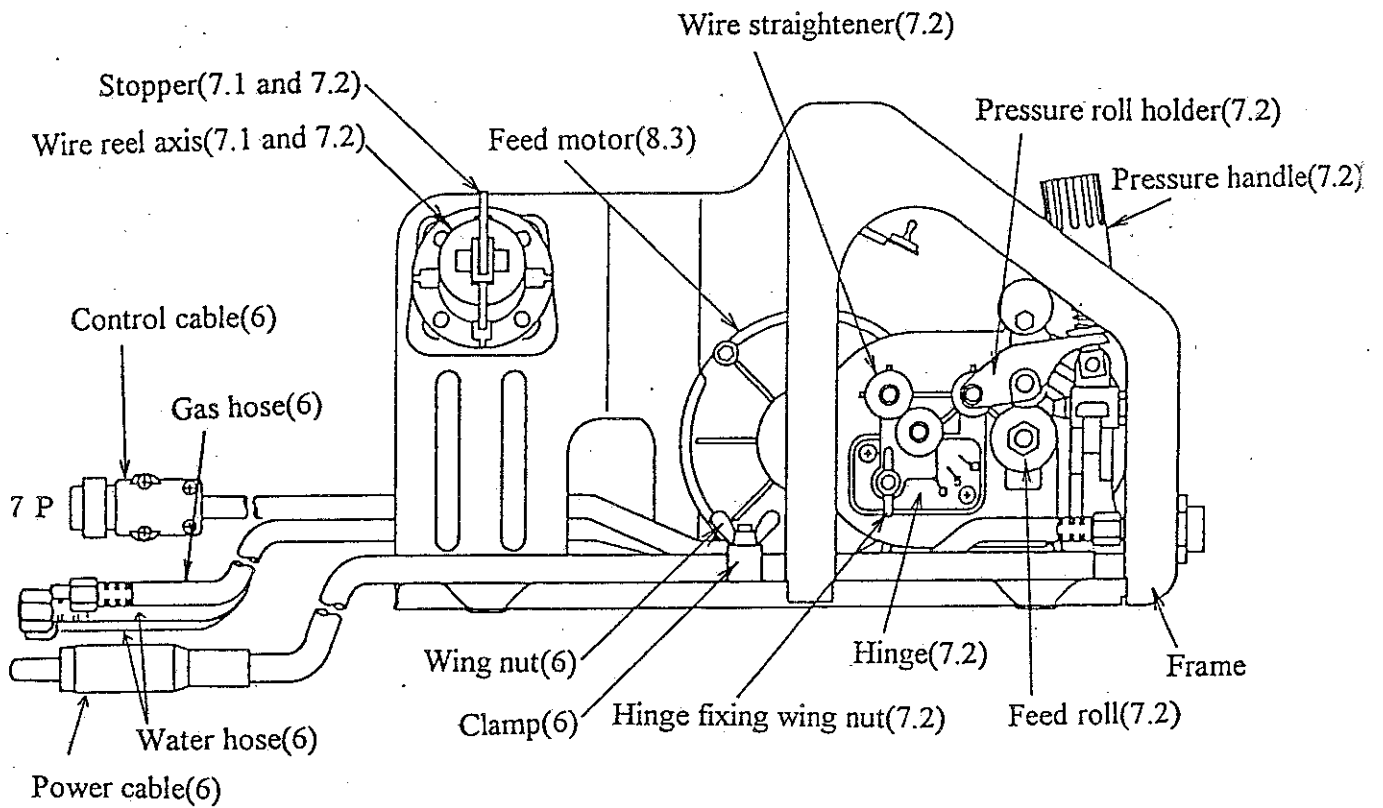

4. EACH DESIGNATION AND OPERATION

- () is indicated to remarks items.



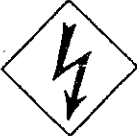

5. TRANSPORTATION AND INSTALLATION

5.1 Transportation

⚠ WARNING	
Observe the following to prevent troubles in running and breakage of the welding machine.	
	<ul style="list-style-type: none"> ● When carrying or transferring the wire feeder, be sure to turn OFF input power supply by the line disconnect switch.
	<ul style="list-style-type: none"> ● When carrying the wire feeder to height, remove the wire from wire feeder.

5.2 Installation

⚠ CAUTION	
In installing the welding machine, observe the following to prevent occurrence of fires by welding and physical damage by fume gas.	
	<ul style="list-style-type: none"> ● Do not install the welding machine near combustible materials and inflammable gas. ● Remove combustible materials not to attach the spatter to them. If not removed, cover combustible materials with the noncombustible cover.
	<ul style="list-style-type: none"> ● For preventing gas-poisoning at choking, use local exhaust equipment or use protectors for respiration. ● In welding at narrow space, ventilate the place sufficiently or wear the protectors for respiration, and work under supervision by a trained supervisor.

INSTALLATION PLACE

- Observe the following when selecting a installation place.
 - Less humidity, dirt and dust. And do not expose welding machine to direct sun light, wind and rain.
 - Ambient temperature is 14~72° F.
 - There is not window.
(Use a wind shield to protect arc from wind, otherwise blow hole may be caused.)

⚠ WARNING
● Be sure to turn OFF the line disconnect switch before connection.

⚠ CAUTION
● Securely tighten connecting parts of cables.

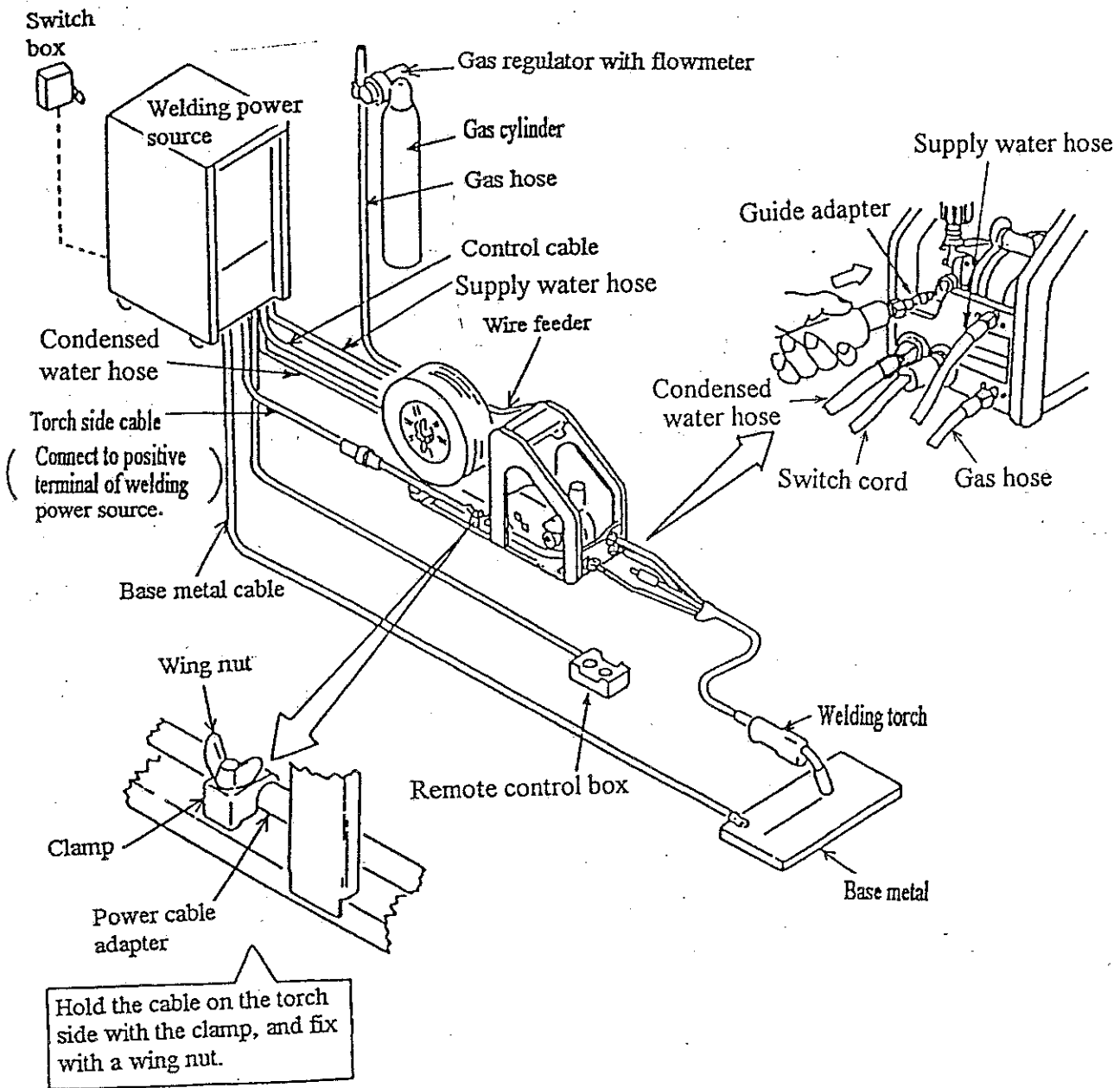

7. WELDING PREPARATION

7.1 Replace the wire reel axis at vertically installation

(When wire feeder is installed on horizontal space, this operation is not necessary)



CAUTION

- To prevent the wire dropping, be sure to observe the following at welding operation with hanging the wire feeder.

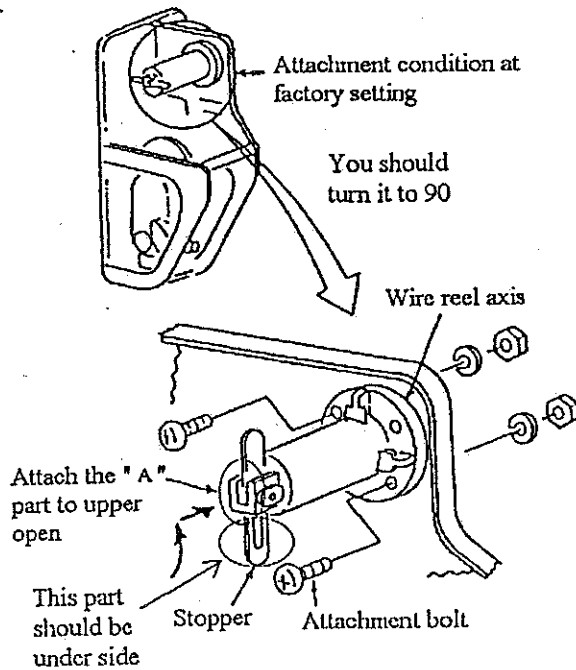

- Set "A" part side of the wire reel axis to upper open, and tighten bolts securely.

Commended tightening torque:
12 N · cm {122kg · cm}

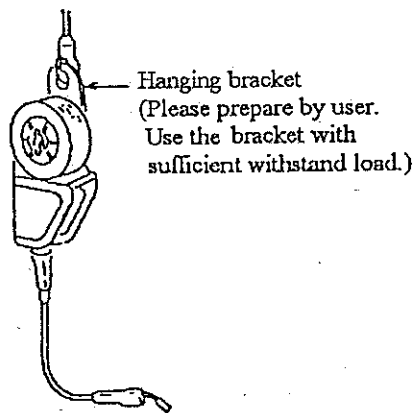

- Securely set the stopper as standing vertically to prevent the wire dropping of after the wire is attached.

7.2 Fitting of wire

Check of wire size of the feed roll and pressure roll

- ① Check that fitting of the feed roll and pressure roll matches with the welding wire size.

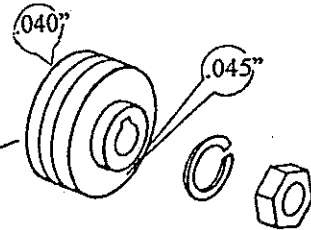
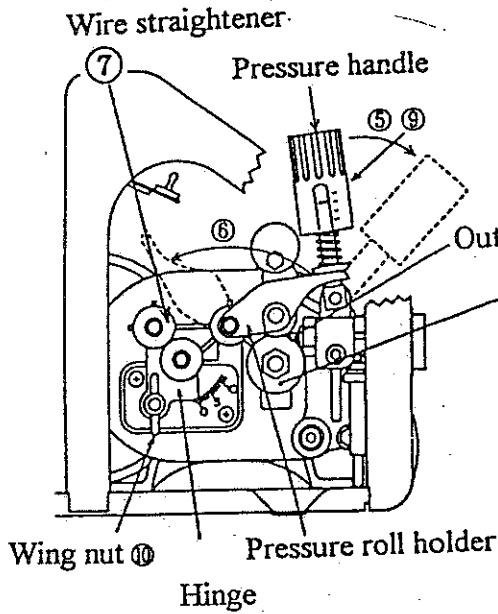

Fit the feed roll to be able to see the same marking numeric value as the wire size to be used.

Fitting of wire

- ② Raise the stopper and bring it down.
- ③ Fit the wire to the wire reel axis.
- ④ Return the stopper as it was to place vertically.

CAUTION

• Be sure to return the stopper vertically as it was to prevent dropping of the wire.

- ⑤ Bring down the pressure handle.
- ⑥ Raise the pressure roll holder.
- ⑦ Pull out the wire to let it through the wire straightener, and insert it into the outlet guide.
- ⑧ Return the pressure roll holder and the pressure handle, in this holder.

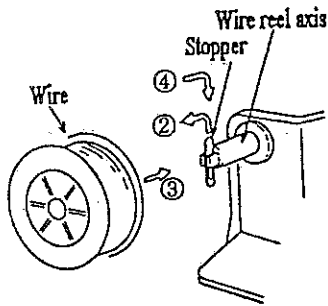





Adjusting of pressure and straightener

- ⑨ Rotate the pressure handle to set pressure force matching the wire diameter.
- ⑩ Loosen the wing nut, rotate the hinge and fix it at an appropriate position.



WIRE STRAIGHTENER ADJUSTMENT		WIRE PRESSURE HANDLE ADJUSTMENT	
WIRE	HINGE GRADUATION	WIRE	HANDLE GRADUATION
1/16	0~2	1/16	5~6
.045	1~3	.045	5~6
.035	2~4	.035	3~4
.030	3~5	.030	2~3

7.3 Wire feeding by inching operation

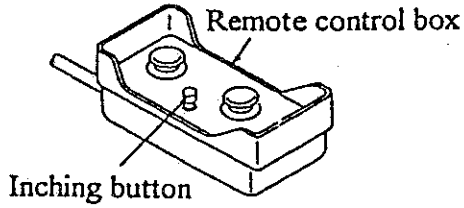
 WARNING	
	● Do not look into the chip hole to check on sending of the wire in inching.
 WARNING	
	● Do not put your hands, fingers, hair and clothes near the rotating parts of the feed roll, etc. in inching. Biting may occur, causing injuries.

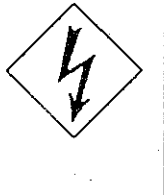

① Feed the wire while stretching the welding torch straight and pressing the inching button, and release from the button where the wire is projected from the welding torch tip by about 10mm.

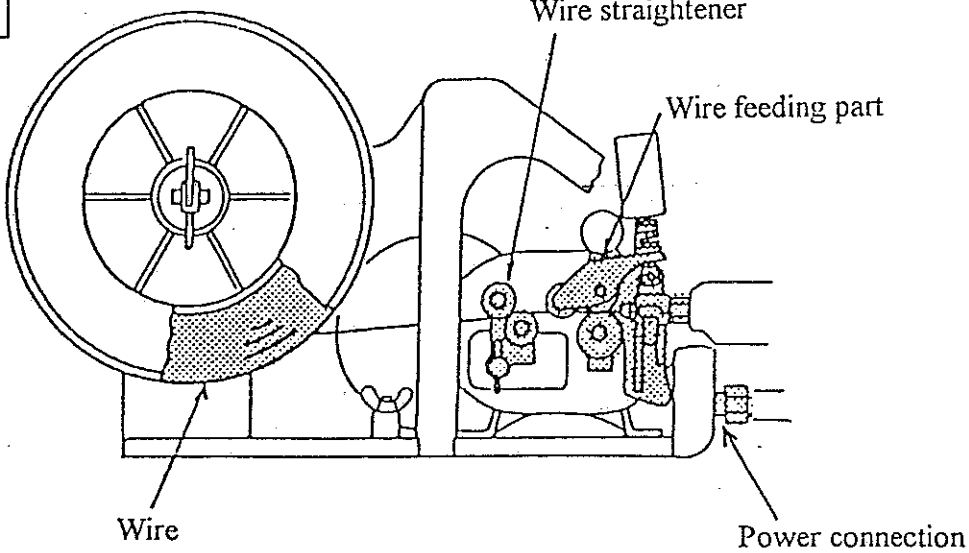
 WARNING	
※ Touching the electrification parts may cause fatal electric shock and burn.	
	● Never touch the charge parts of wire and wire feeder.  part is indicated to charging part at welding.
 <p>Wire straightener Wire feeding part Wire Power connection</p>	

8. MAINTENANCE AND REPAIR OF TROUBLES

8.1 Inspection in working

Parts	Inspection point	Trouble	Measures
Pressure scale	● Is pressure force matching with the wire diameter?	Pressure force is too weak or too strong.	Match pressure force with the value of wire pressure adjustment recommended in item 7.2.
Outlet guide	● Are not chips and dusts left around the inlet of the outlet guide and the feed roll?	Chips and dusts are left.	Remove chips and dusts.
Feed roll	● Are the wire diameter and the marking of the feed roll matching?	Wire diameter and the marking do not match.	Change to the feed roll matching with the wire diameter.
	● Wire touching surface condition.	The surface is worn.	Replace to new one.
Pressure roll	● Does the roll rotate smoothly.	The roll does not rotate smoothly.	Replace to new one
Wire straightener	● Are not chips and dusts left?	Chips and dusts are left.	Remove chips and dusts.
	● Does the roll rotate smoothly.	The roll does not rotate smoothly.	Remove chips and dusts, or replace to new one.
Cable	● Is not the cable coating broken, or is not the cable liable to be disconnected?	The coating is broken or the cable is likely to be disconnected.	Replace to new one.
	● Is not the connecting part loosened?	The connecting part is loosened.	Firmly tighten.
Gas hose	● Is not crazing formed?	Crazing is formed.	Replace to new one.

8.2 Yearly inspection

(1) Grease replacement of reduction gear

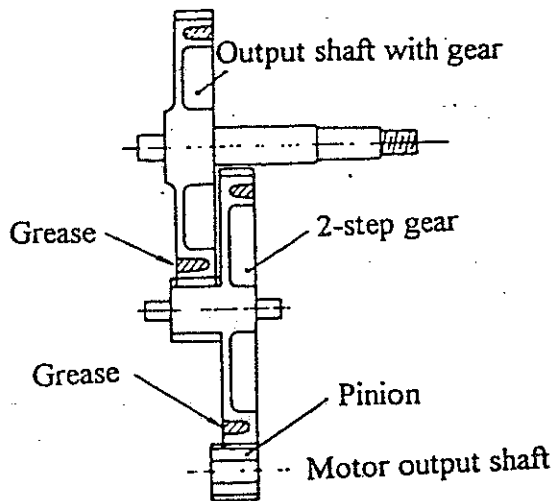

After removing aged grease, apply new one to the gear tooth surface and side faces as shown in figure.

Use the grease No.1 of each lithium type.

CAUTION

Never fill the gear box with grease, otherwise motor will be burnt.

(2) Replacement of feed motor

CAUTION

- Never disassemble the feed motor. It is caused in troubles.
- Never replace and check of brush.

Usually service life of brush is about 4,000 hours (about two years, if it works six hours a day).
Replace the feed motor periodically.

9. PARTS LIST

Please order parts necessary for repair from OTC or its agents, indicating description, item No., and part No..

9.1 Wire feeding reduction gear unit (Refer to Fig. 2)

Item	Part No.	Description	Q'ty	Remarks
1	K1123B01	Gear case	1	
2	4802-006	Print motor	1	
3		Screw (small)	4	M5-20
4		Spring washer	4	M5
5		Washer	4	M5
6		Nut	2	M5
7	U2057B01	Pinion	1	
8		Screw (M6 × 6)	1	
9	K1821B02	2-step gear	1	
10	K1123B05	Bush	2	
11	K1123B04	Output shaft with gear	1	
12	K1123B06	Insulating spacer	1	
13	3311-001	Radial ball bearing	1	No. 6000ZZ
14	3361-206	Key	1	4 × 4 × 8
15	3311-008	Radial ball bearing	1	No. 6001LL
16	K1200B01	Gear case	1	
16-1	K1200B04	Torch holder	(1)	
16-2	K1200B05	Gear case	(1)	
16-3	U1230B14	Insulating washer	(1)	
16-4		Hexagon rod bolt	(1)	M6-35
16-5		Hexagon rod bolt	(1)	M6-40
17	K1123B07	Spacer	1	
18	K1678H05	Feed roll (35/1000 - 45/1000)	1	
19		Washer	1	M10
20		Spring washer	1	M10
21		Nut	1	M10
22	K1200B02	Bolt fixing plate	1	
23		Screw (small)	2	M5-20
24		Spring washer	2	M5
25	K1123F00	Hinge assembly	1 set	
26	K1123C01	Pressure roll holder	1	
27	K1123C05	Pressure roll shaft	1	
28	3311-003	Radial ball bearing	1	No. 6200LL
29		Washer	2	M10
30	K1123C06	Straight roll (1)	1	with bush
31	K1123C07	Straight roll (2)	2	with bush
32	3361-402	Thrust washer	4	STW-FT-8.0 × 0.5
33	3361-403	E-type snap ring	4	for φ 6
34	3361-503	Cup square neck bolt	1	B type M8-40
35	3361-505	Wing nut	1	M8

Item	Part No.	Description	Q'ty	Remarks
36	3361-208	Spring roll pin	1	φ 3-20
37	U785C13	Guide adapter	1	
38	K1200B03	Spring plate	1	
39	U785C11	Protection cover	1	
40		Screw(small)	1	M4-8
41		Spring washer	1	M4
42		Nut	1	M4
43		Screw	1	M5-6
44		Spring washer	1	M5
45	K1123D00	Pressure handle assembly	1 set	
46		Hexagon rod bolt	2	M6-25
47		Spring washer	3	M6
48		Nut	1	M6
48-1		Loose fixing nut	1	M6
49	K1200B06	Remote stopper	1	

9.2 Others

Item	Part No.	Description	Q'ty	Remarks
50	U4179B00	Frame body	1	
51	4813-001	Gas solenoid valve	1	W-31156, DC25V
52	K476B00	Spindle type wire reel	1	
53	U3557C01	Wire reel cover	1	
54	U1997C01	Cable clamp	1	
55	U3403C00	Gas hose assembly	1	
56	U4379E00	Control cable assembly	1	
56-1	4730-619	Plug socket	(1)	7P
57	U2063D00	Cooling water hose(supply water)	1	2.5 m
58	U2063E00	Cooling water hose(condensed water)	1	2.5 m
59	U2879D00	Power connection	1	
60	U2063G00	Power cable	1	

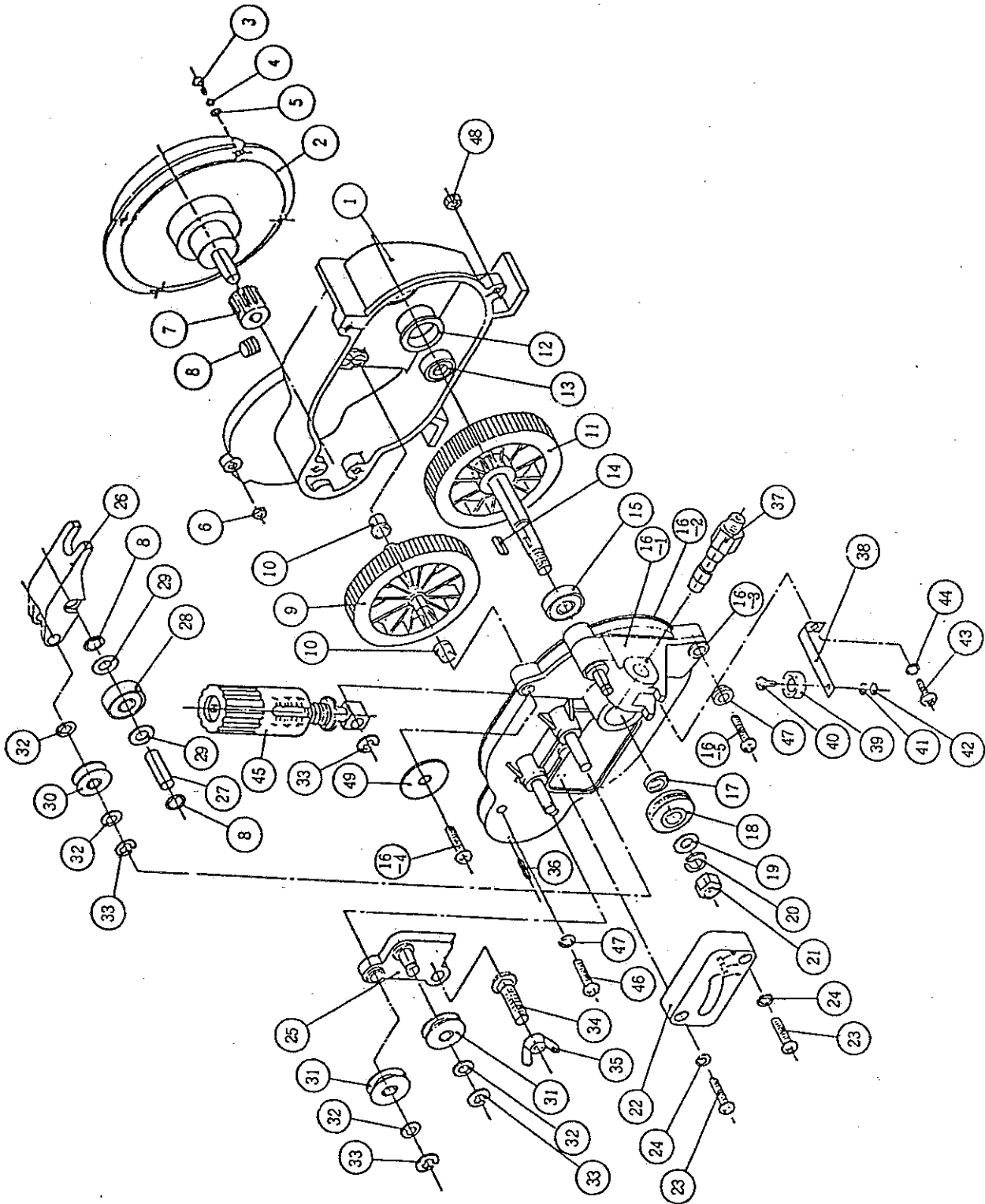

Fig.1 Disassembly drawing of wire feeder

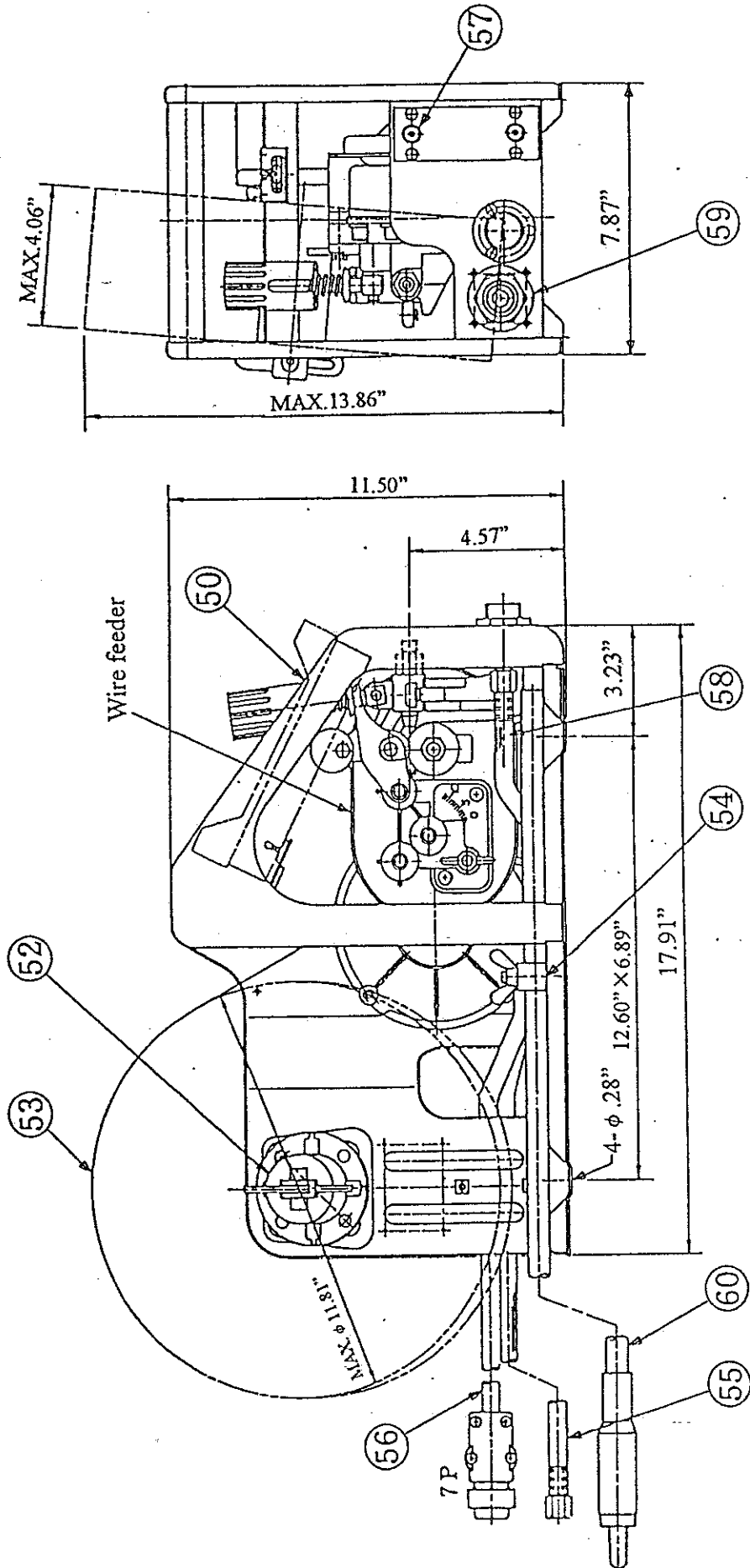

Fig.2 External view of wire feeder

10. SPECIFICATION

10.1 Specification

Model	CMWH-231	
Applicable wire size	35/1000 in, 45/1000 in	
Applicable wire	Solid wire, cored wire	
Wire feeding speed	Max. 59.1 ft / min	
Applicable wire reel	Shaft dia.	ϕ 1.97"
	Outer dia.	Max. ϕ 11.81"
	Width	4.06"
Applicable wire mass	Max. 11.34 lb	
Approximate mass	24 lbs	

10.2 Combination torch

WTCSW-5001 CO₂/MAG torch (500A water cooled curved type)

WTGSW-5001 CO₂/MAG torch (500A water cooled gun type)

10.3 Standard accessories

Description	Part No.	Q'ty	Remarks
Welding cable (torch)	U1997H00	1	.093 in ² × 5.25 ft
Welding cable (grounding)	U1997J00	1	.093 in ² × 5.91 ft
Plug socket	U3396E00	1	