

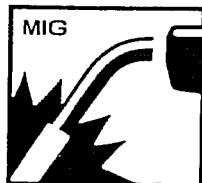

OWNER'S MANUAL

FOR



CMH - 147

MODEL: CMH-147 U4450

DO NOT DESTROY

IMPORTANT: Read and understand the entire contents of this manual, with special emphasis on the safety material throughout the manual, before installing, operating, or maintaining this equipment. This equipment and this manual are for use only by persons trained and experienced in the safe operation of welding equipment. Do not allow untrained persons to install, operate or maintain this equipment. Contact your distributor if you do not fully understand this manual.

DAIHEN Corporation WELDING PRODUCTS DIVISION

1: February 17, 1998

Upon contact, advise MODEL and MANUAL NO.

Notice : Machine export to Europe

This product does not meet the requirements specified in the EC Directives which are the EU safety ordinance that was enforced starting on January 1, 1995. Please make sure that this product is not allowed to bring into the EU after January 1, 1995 as it is. The same restriction is also applied to any country which has signed the EEA accord.

Please ask us before attempting to relocate or resell this product to or in any EU member country or any other country which has signed the EEA accord.

CONTENTS

1. SAFETY INFORMATION	2
2. ARC WELDING SAFETY PRECAUTIONS	2
3. CHECKING OF PACKAGE CONTENTS	8
4. EACH DESIGNATION AND OPERATION	8
5. TRANSPORTATION AND INSTALLATION	9
6. CONNECTION	10
7. WELDING OPERATION	11
8. MAINTENANCE AND REPAIR OF TROUBLES	13
9. PARTS LIST	15
10. SPECIFICATION	21

1. SAFETY INFORMATION

The following safety alert symbols and signal words are used throughout this manual to call attention and to identify different levels of hazard and special instructions.

	WARNING	WARNING gives information regarding possible personal injury or loss of life.
---	----------------	---

	CAUTION	CAUTION refers to minor personal injury or possible equipment damage.
---	----------------	---

2. ARC WELDING SAFETY PRECAUTIONS

 WARNING	
ARC WELDING can be hazardous.	
◆	<p>PROTECT YOURSELF AND OTHERS FROM POSSIBLE SERIOUS INJURY OR DEATH. Especially:</p> <ul style="list-style-type: none"> • Keep children away. • Pacemaker wearers keep away until consulting a doctor.
◆	<p>Read and understand</p> <ul style="list-style-type: none"> • the summarized safety information given below and the original principal information that will be found in the table SAFETY STANDARDS.
◆	<p>Have only trained and experienced persons perform installation, operation, and maintenance of this equipment.</p>
◆	<p>Use only well-maintained equipment. Repair or replace damaged parts at once.</p>
ARC WELDING is safe when precautions are taken.	



ELECTRIC SHOCK can kill.

Touching live electrical parts can cause fatal shocks or severe burns. The electrode and welding circuit is electrically live whenever the output of the welding power source is on. The power line and internal circuit of the welding power source are also live when line disconnect switch is on. In semiautomatic or automatic wire welding, wire reel, drive assembly, and all metal parts touching the welding wire are electrically live.

1. Do not touch live electrical parts.
2. Wear dry, hole-free insulating gloves and body protection.
3. Insulate yourself from work and ground using dry insulating mats or covers.
4. Disconnect line disconnect switch before installing, changing torch parts or maintaining this equipment.
5. Properly install and ground this equipment according to its Owner's Manual and national, state, and local codes.
6. Ground the base metal.
7. Keep all panels and covers of this equipment securely in place.
8. Do not use worn, damaged, undersized, or poorly spliced cables.
9. Do not touch electrode and any metal object if POWER switch is 'ON'.
10. Do not wrap weld cables around your body.
11. Turn off POWER switch when not in use.



ARC RAYS can burn eyes and skin: FLYING SPARKS AND HOT METAL can cause injury. NOISE can damage hearing.

Arc rays from the welding produce intense heat and strong ultraviolet rays that can burn eyes and skin. Noise from some arc welding can damage hearing.

1. Wear a face protection with a proper shade of filter (See ANSI Z 49.1 listed in table SAFETY STANDARDS.) to protect your face and eyes when welding or watching.
2. Wear approved safety goggles.
3. Use protective screens or barriers to protect others from flash and glare: warn others not to watch the arc.
4. Wear protective clothing made from durable, flame-resistant material (wool and leather) and foot protection.
5. Use approved ear plugs or ear muffs if noise level is high.



WELDING can cause fire and explosion.

Sparks and spatter fly from the welding arc. The flying sparks and hot metal, spatter, hot workpiece, and hot equipment can cause fires and explosion.

1. Protect yourself and others from flying sparks and hot metal.
2. Do not weld where flying sparks can strike flammable material.
3. Remove all flammables within 35ft. (10.7m). If this is not possible, tightly, cover them with approved covers.
 - Be alert that welding sparks and hot metals from welding can easily go through small cracks and openings to adjacent areas.
4. Watch for fire, and keep a fire extinguisher nearby
 - Be aware that welding on a ceiling, floor, bulkhead, or partition can cause fire hidden side.
5. Do not weld on closed containers such as tanks or drums.

Accidental contact of electrode or welding wire to metal object can cause sparks, overheating, or fire.

6. Contact work cable to base metal as close to the welding area as practical
 - to prevent welding current from traveling long, possibly unknown paths and causing electric shock and fire hazards.
7. Remove stick electrode from holder; cut off wire at contact tip when not in use.
8. Do not use the welding power source for other use than arc welding.
9. Wear oil-free protective garments such as leather gloves, heavy shirt, cuffless trousers, high shoes, and a cap. Loose weld cable connection can cause undesired sparks and excessive heating.
10. Tighten all weld cable connections.

Chipping and grinding cause flying metal. As welds cool, they can throw off slag.

11. Wear approved face shield or safety goggles. Side shield recommended.
12. Wear proper body protection to protect skin.



FUMES AND GASES can be hazardous to your health.

Arc welding may produce fumes and gases hazardous to health.

1. Keep your head out of the fumes; do not breathe the fumes.
2. Ventilate the area and / or use exhaust at the arc to remove welding fumes and gases.
3. If ventilation is poor, use an approved air-supplied respirator.
4. Read the Material Safety Data Sheets (MSDSs) and the manufacture's instruction for metals, consumables, coatings, and cleaners.
5. Do not cut in locations near degreasing, cleaning, or spraying operations.
The heat and rays of the arc can react with vapors to form highly toxic and irritating gases.



CYLINDER can explode if damaged.

Shielding gas cylinder contain high pressure gas. If damaged, a cylinder can explode.

1. Use only correct gas cylinders, regulators, hoses, and fittings designed for the specific application; maintain them in good condition.
2. Protect gas cylinder from excessive heat, mechanical shock, and arcs.
3. Keep cylinder in an upright position securely chained to stationary support or rack to prevent falling or tipping.
4. Keep cylinders away from any welding or other electrical circuit.
5. Never touch cylinder with welding electrode.
6. Read and follow instructions on compressed gas cylinders, associate equipment, and CGA publication listed in table SAFETY STANDARDS.

Since gas cylinders are normally part of the welding process, be sure to treat carefully.

7. Turn face away from valve outlet when opening cylinder valve.
8. Keep protective cap in place over valve except when gas cylinder is in use or connected for use.



Rotating parts may cause injuries. Be sure to observe the followings.

If hands, fingers, hair and clothes are put near the rotating parts of wire feeding roll of the feeder, biting may occur, causing injuries.

1. Do not use the welding machine in removing the case and the cover.
2. When the case is removed in maintenance/inspection and repair, certified operators or operators knowing the welding machine well must perform the working. By providing a fence, etc. around the welding machine, do not let other persons come near the welding machine carelessly.
3. Do not put your hands, fingers, hair ad cloths near the wire feeding roll rotating.

ARC WELDING WORKSHOP is potentially hazardous.

FALLING, FALLING DOWN and MOVING machine can cause serious injury.

- ◆ Do not lift the welding power source with one eyebolt.
Use two eyebolts to lift it.
- ◆ Put the welding power source and wire feeder solidly on a flat surface.
- ◆ Do not pull the welding power source on floor laid with cables and hoses.
- ◆ Do not put wire feeder on the welding power source.
- ◆ Do not put the welding power source and wire feeder where they will pit or fall.

WELDING WIRE can cause puncture wounds.

- ◆ Do not press gun trigger until instructed to do so.
- ◆ Do not point gun toward any part of the body, other people, or any metal when threading welding wire.

PRINCIPAL SAFETY STANDARDS

Safety in Welding and Cutting, ANSI Standard Z49.1, from American Welding Society, 550 N.W. Lejeune Rd, Miami FL 33126.

Safety and Health Standards, OSHA 29 CFR 1910, from Superintendent of Documents, U.S. Government Printing Office, Washington, D.C.20402.

Recommended Practices for Plasma Arc Cutting, American Welding Society Standard AWS C5.2, from American Welding Society, 550 N.W.Lejeune Rd, Miami, FL 33126.

Recommended Safe Practices for the Preparation for Welding and cutting of containers That Have Held Hazardous Substances, American Welding Society Standard AWS F4.1, from American Welding Society, 550 N.W.Lejeune Rd, Miami, FL 33126.

National Electrical Code, NFPA Standard 70, from National Fire Protection Association, Batterymarch Park, Quickly, MA02269.

Safe Handling of Compressed Gases in Cylinders, CGA Pamphlet P-1, from Compressed Gas Association, 1235 Jefferson Davis Highway, Suite 501, Arlington, VA 22202.

Code for Safety Welding and Cutting, CGA Standard W117.2, from Canadian Standards Association, Standards Sales, 178 Rexdale Boulevard, Rexdale, Ontario, Canada M9W 1R3.

Safe Practices For Occupation And Educational Eye And Face Protection, ANSI Standard Z87.1, from American National Standards Institute, 1430 Broadway, New York, NY10018.

Cutting And Welding Processes, NFPA Standard 51B, from National Fire Protection Association, Batterymarch Park, Quickly, MA 02269.

3. CHECKING OF PACKAGE CONTENTS

- Check of quantity at open the package.

Wire feeder

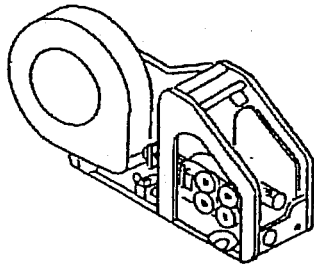

• Standard accessories

Description	Specification	Q'ty
Gas hose	9.84ft.	1
Welding cable(Torch side)	.093in ² × 5.25ft.	1
Welding cable (Base metal side)	.093in ² × 5.90ft.	1
Hexagon rod spanner	No. 6	1
Plug socket	2P	1

4. EACH DESIGNATION AND OPERATION

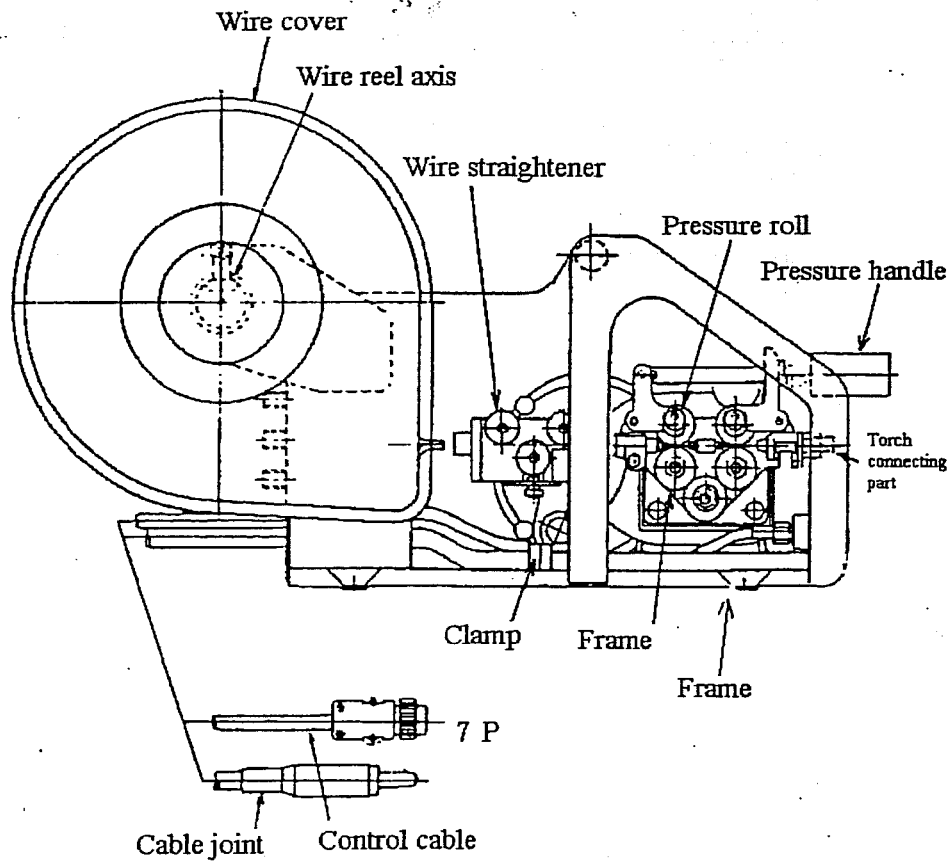

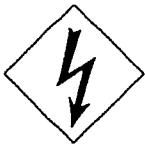
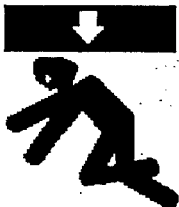

5. TRANSPORTATION AND INSTALLATION

5.1 Transportation

⚠ WARNING	
Observe the following to prevent troubles in running and breakage of the welding machine.	
	<ul style="list-style-type: none"> ● When carrying or transferring the wire feeder, be sure to turn OFF input power supply by the line disconnect switch.
	<ul style="list-style-type: none"> ● When carrying the wire feeder to height, remove the wire from wire feeder.

5.2 Installation

⚠ CAUTION	
In installing the welding machine, observe the following to prevent occurrence of fires by welding and physical damage by fume gas.	
	<ul style="list-style-type: none"> ● Do not install the welding machine near combustible materials and inflammable gas. ● Remove combustible materials not to attach the spatter to them. If not removed, cover combustible materials with the noncombustible cover.
	<ul style="list-style-type: none"> ● For preventing gas-poisoning at choking, use local exhaust equipment or use protectors for respiration. ● In welding at narrow space, ventilate the place sufficiently or wear the protectors for respiration, and work under supervision by a trained supervisor.

INSTALLATION PLACE

- Observe the followings when selecting a installation place.
 - Less humidity, dirt and dust. Do not expose welding machine to direct sun light, wind and rain.
 - Ambient temperature is 14~104° F.
 - There is not window.
 (Use a windshield to protect arc from wind, otherwise blowhole may be caused.)

6. CONNECTION

⚠ WARNING

● Be sure to turn OFF the line disconnect switch before connection.

⚠ CAUTION

● Securely tighten connecting parts of cables.

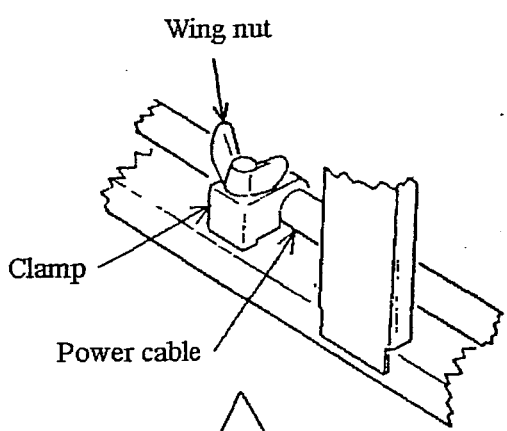
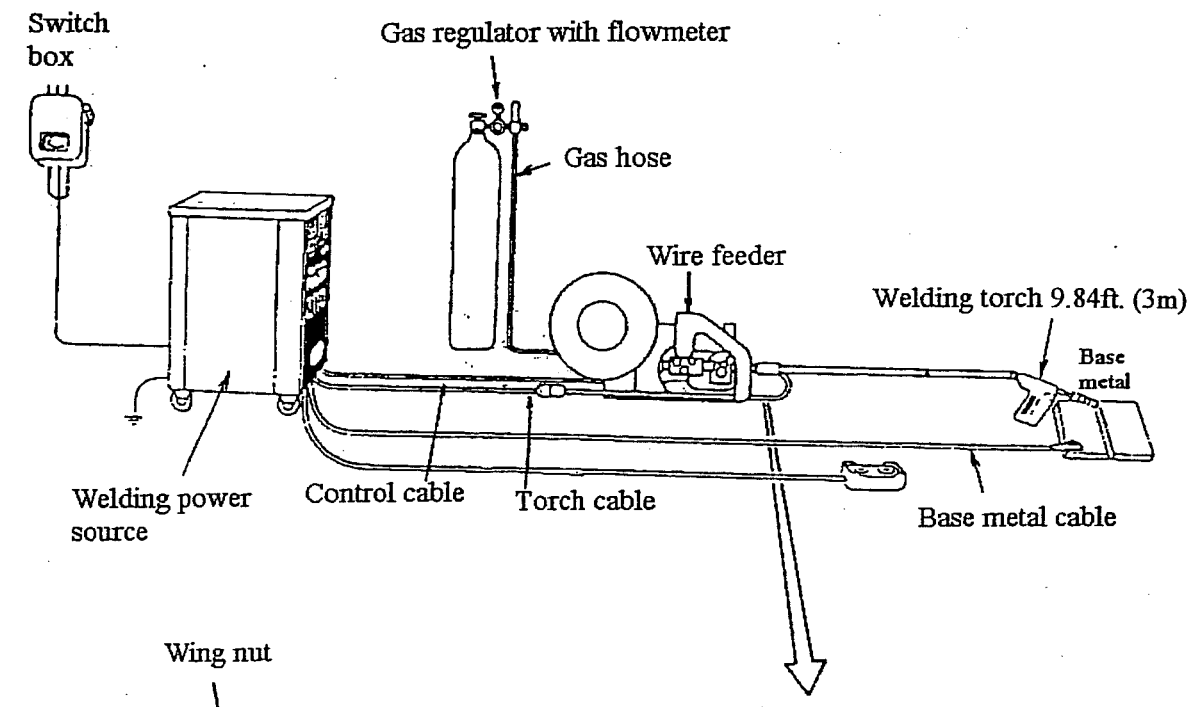

Hold the cable on the torch side with the clamp, and fix with a wing nut.

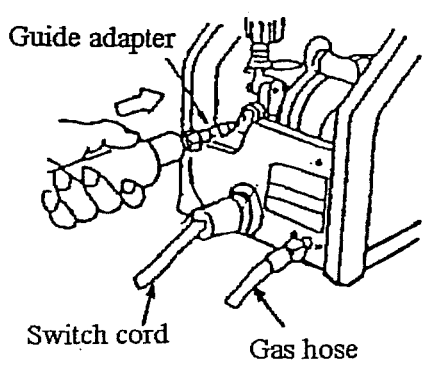

7. WELDING OPERATION

7.1 Fitting of wire

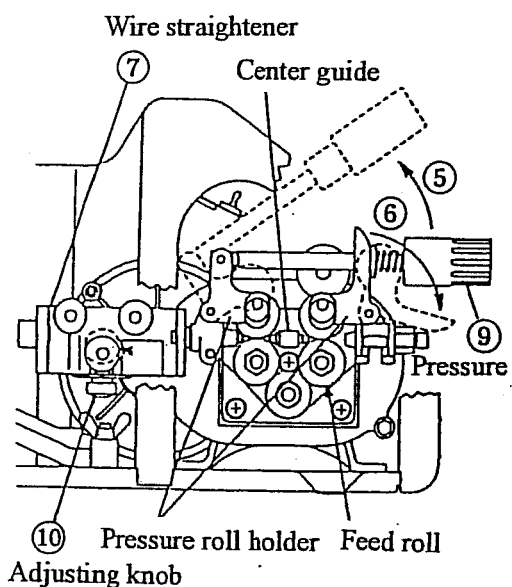

Check of wire size of the feed roll and pressure roll

- ① Check that fitting of the feed roll and pressure roll matches with the welding wire size.

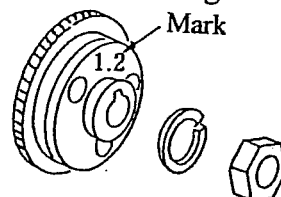

Fit the feed roll to be able to see the same marking numeric value as the wire size to be used.

Fitting of wire

- ② Raise the stopper and bring it down.
- ③ Fit the wire to the wire reel axis.
- ④ Return the stopper as it was to place vertically.

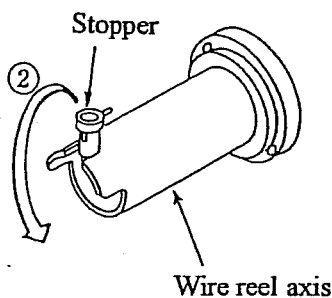

⚠ CAUTION

Be sure to return the stopper vertically as it was to prevent dropping of the wire.

- ⑤ Bring up the pressure handle.
- ⑥ Bring down the pressure roll holder.
- ⑦ Pull out the wire to let it through the wire straightener, and insert it into the outlet guide.
- ⑧ Return the pressure roll holder and the pressure handle, in this holder.





Adjusting of pressure and straightener

- ⑨ Rotate the pressure handle to set pressure force matching the wire diameter.
- ⑩ Loosen the wing nut, rotate the hinge and fix it at an appropriate position.

Adjustment of pressure



Aluminum		Stainless steel	Pressure handle scale
Hard	Mild	Mild steel	
1/16	—	.045	3~4
3/64	1/16	.035	2~3
.035	3/64	—	1~2

7.2 Wire feeding by inching operation

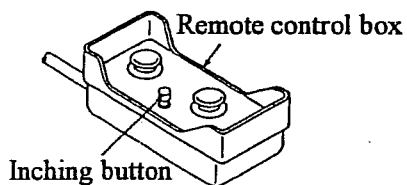
 WARNING	
	● Do not look into the chip hole to check on sending of the wire in inching.
 WARNING	
	● Do not put your hands, fingers, hair and clothes near the rotating parts of the feeding roll, etc. in inching. Biting may occur, causing injuries.

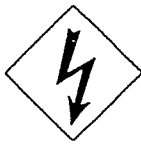

① Feed the wire while stretching the welding torch straight and pressing the inching button, and release from the button where the wire is projected from the welding torch tip by about .39".

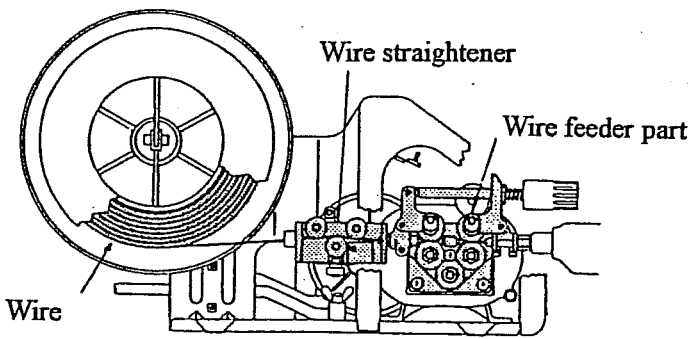
 WARNING	
※ Touching the electrification parts may cause fatal electric shock and burn.	
	<ul style="list-style-type: none">● Never touch the charge parts of wire and wire feeder.●  part is indicated to charging part at welding.● Be sure to close the cover at welding.
 <p>Wire straightener</p> <p>Wire feeder part</p> <p>Wire</p>	

8. MAINTENANCE AND REPAIR OF TROUBLES

8.1 Inspection in working

Parts	Inspection point	Trouble	Measures
Pressure scale	● Is pressure force matching with the wire diameter?	Pressure force is too weak or too strong.	Match pressure force with the value of wire pressure adjustment recommended in item 7.2.
Inlet guide Center guide	● Do not chips and dusts accumulate around the inlet of the inlet guide and the feed roll?	Chips and dusts accumulate.	Remove chips and dusts.
Feed roll	● Are the wire diameter and the marking of the feed roll matching?	Wire diameter and the marking do not match.	Change to the feed roll matching with the wire diameter.
	● Wire touching surface condition.	The surface is worn.	Replace to new one.
Pressure roll	● Does the roll rotate smoothly?	The roll does not rotate smoothly.	Replace to new one
Wire straightener	● Do not chips and dusts accumulate?	Chips and dusts rotate accumulate.	Remove chips and dusts.
	● Does the roll rotate smoothly?	The roll does not rotate smoothly.	Remove chips and dusts, or replace to new one.
Cable	● Is not the cable coating broken, or is not the cable liable to be disconnected?	The coating is broken or the cable is likely to be disconnected.	Replace to new one.
	● Is not the connecting part loosened?	The connecting part is loosened.	Firmly tighten.
Gas hose	● Is there any cracks?	Gas hose is cracked.	Replace to new one.

8.2 Yearly inspection

(1) Grease replacement of reduction gear

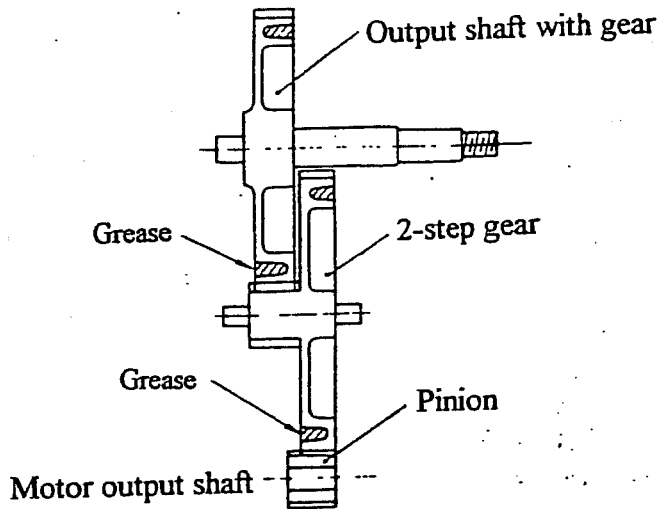

After removing aged grease, apply new one to the gear tooth surface and side faces as shown in figure.

Use the grease No.1 of each lithium type.

⚠ CAUTION
Apply grease on the side face gear as shown in this figure. Never fill the gear box with grease, otherwise motor will be burnt out.

(2) Replacement of feed motor

⚠ CAUTION
• Never disassemble the feed motor. It is caused in troubles. • Never replace and check of brush.

Usually service life of brush is about 4,000 hours (about two years, if it works six hours a day).
Replace the feed motor periodically.

9. PARTS LIST

If parts are required for replacement, direct order involving Description, Symbol and Parts No. to our sales agent or OTC's office directly.

As to standard and optional accessories, please refer to items 9.3.

9.1 Wire feeding reduction gear (Refer to Fig. 1, 2)

Item	Part No.	Description	Q'ty	Remarks
1	K1123B01	Gear case	1	
2	4802-006	Print motor	1	PMEE-12CBB
3	U2057B01	Pinion	1	
3-1		Screw	1	M6-6
4	K1821B02	2-step gear	1	
5	K1123B04	Output shaft with gear	1	
6	3361-206	Key	3	4×4×8
7	K1123B05	Bush	2	
8	K1123B06	Insulating spacer	1	
9	3311-001	Radial ball bearing	1	No. 6000ZZ
10	K1821C01	Gear case	1	
11	K1822C02	Insulating plate	1	
12	K1123C04	Insulating sleeve	1	
13	3311-008	Radial ball bearing	5	No. 6001LL
14	K1822C01	Bracket	1	
15	K5112C04	Pressure roll holder(1)	1	
16	K1822C04	Pressure roll holder(2)	1	
17	K1821C04	Pressure roll pin	2	
18	K1821C05	Axis pin	3	
19	3361-404	E-type snap ring	6	φ 5
20	K5112C05	Pressure bolt	1	
21	U929C16	Pressure spring	1	
22	K1123D01	Pressure handle	1	
23		CS type snap ring	1	CSTW-6
24	K1123D03	Spring bearing	1	
25	K1123D05	Pressure nut	1	
26	K1822C06	Guide block	1	
27	K1822C07	Center guide	1	
28	K1822C09	Feed axis	2	
29	K1822C10	Spacer	3	
29-1	K1123B07	Spacer	1	
30	K1822C11	Middle gear	1	
31	K1821G00	Feed roll (3/64", 1/16")	2	For aluminum
32	K1821H00	Pressure roll (3/64", 1/16")	2	For aluminum
33	U2344B09	Guide adapter	1	
34	U785C09	Spring plate	1	
35	U785C11	Protection cover	1	

Item	Part No.	Description	Q'ty	Remarks
36	K1123C08	Remote stopper	1	
37	U2469C01	Gear case cover	1	
38	K5112C06	Bush	2	For ②
	K1821J00	Wire straightener assembly	(1)	
40	K1821J01	Wire straightener body	1	
41	K1821J02	Patch	1	
42	K1821J03	Adjusting screw	1	
43	U2344C04	Roller shaft	2	
44	3311-014	Radial ball bearing	2	No. 629ZZ
45		E-type snap ring	3	For $\phi 7$
46	U2344C05	Slide shaft	1	
47	U69C02	Radial ball bearing	1	
48	U2344C07	Adapter	1	
49	U2344C08	Pilot	1	
50		Knurled knob	1	KN15
51	U2344C10	Inlet guide	1	

9.2 Others

Item	Part No.	Description	Q'ty	Remarks
52	U4417B00	Frame body	1	Assembly part
53	U4417D00	Gas hose assembly	1	Assembly part
53-1	4813-001	Gas solenoid valve	1	D.C.25V
54	U4377E00	Control cable assembly	1	Assembly part
54-1	4730-619	Plug socket	(1)	7P
55	K536A00	Spindle type wire reel	1	
56	U359C01	Wire reel cover	1	
57	U1779C01	Cable clamp	1	
58	4730-002	Receptacle	1	2P
59	4739-020	Terminal block	1	KM-20-6P

9.3 Optional accessories

Description	Part No.	Q'ty	Remarks
Argon gas regulator with flowmeter	RF-16D	1	Max. flow 28 l/min
Caster	U1997G00	1	

● In case of using mild steel wire and stainless steel wire (ϕ 0.035", ϕ 0.045").

Description	Part No.	Q'ty	Remarks
Feed roll (for ϕ 0.035")	K1821V00	2	
Feed roll (for ϕ 0.045")	K1822P00	2	
Pressure roll	K1822H00	2	For steel
Outlet guide	K3985E02	1	.035" - 3/64"

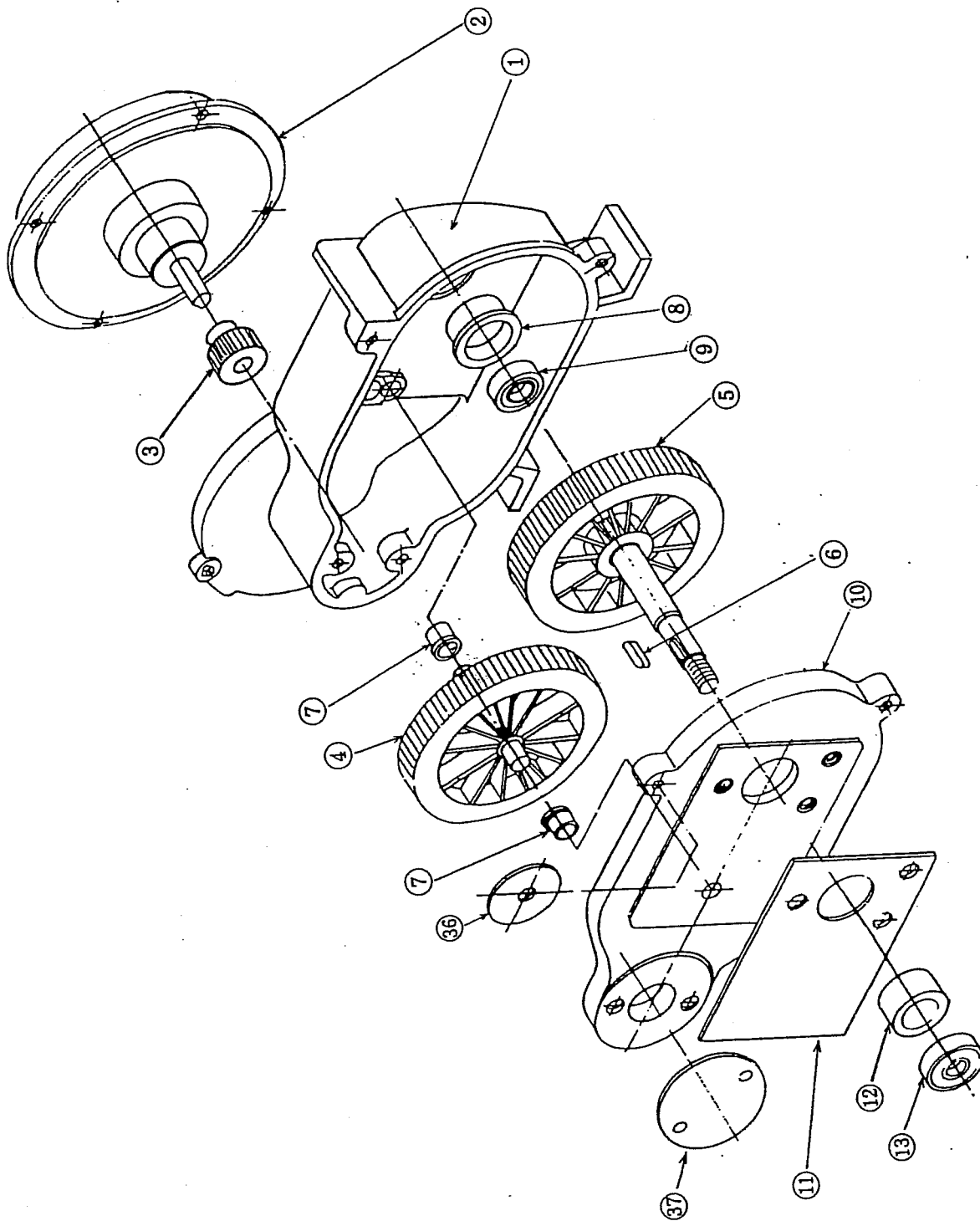

Fig. 1 Disassembly drawing of wire feed reduction gear unit

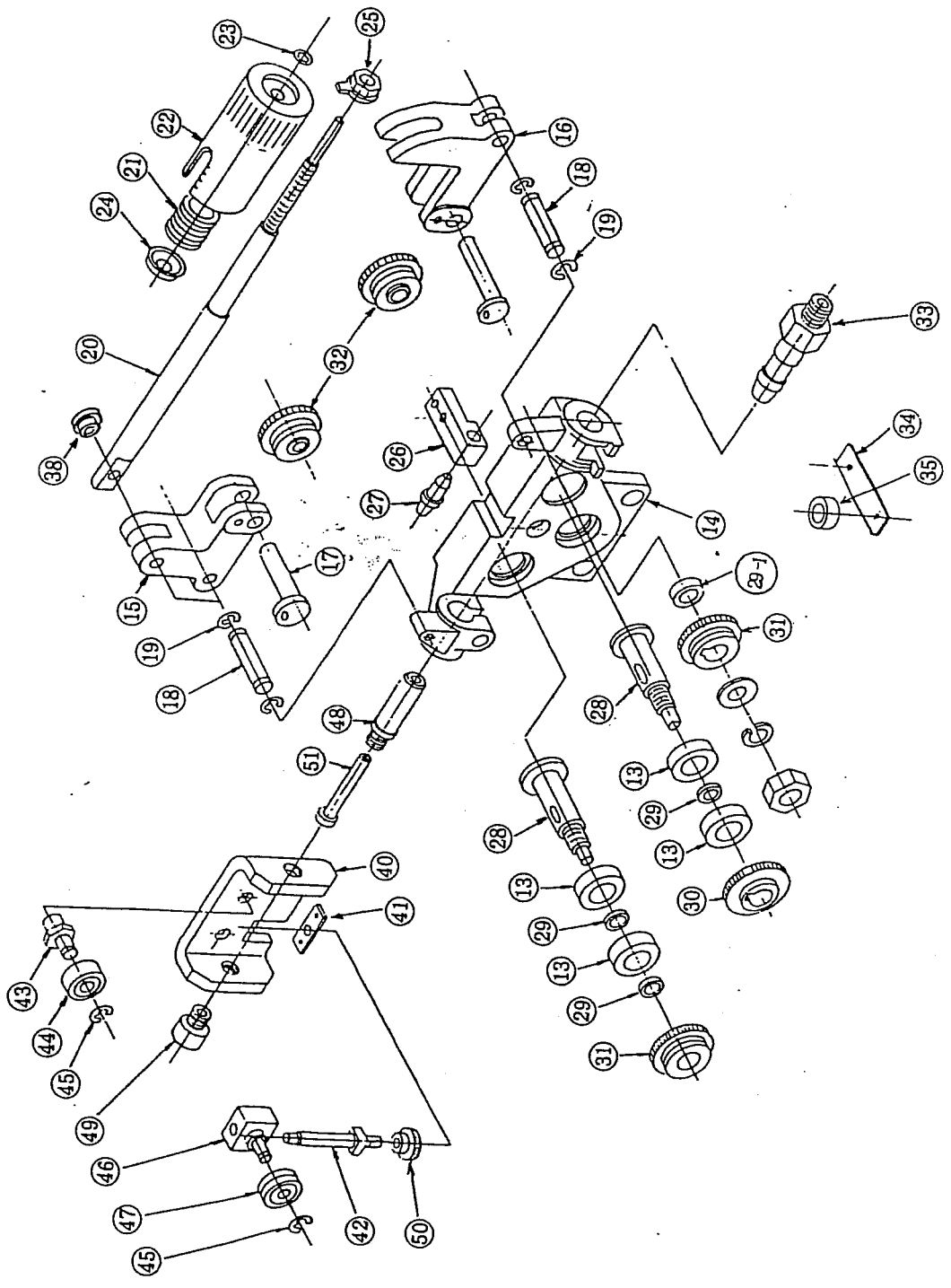

Fig.2 Disassembly drawing of wire feeder and pressure part

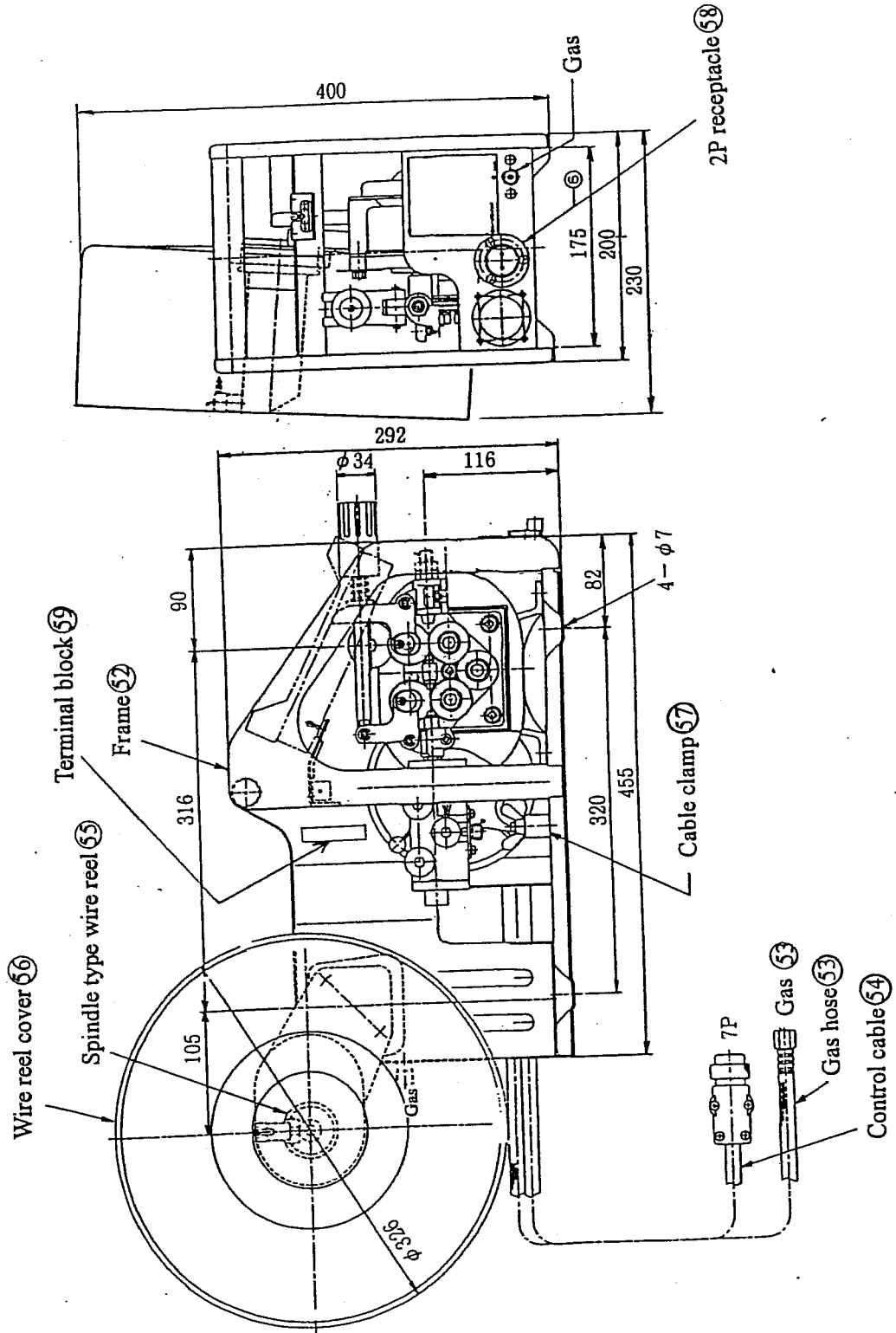

Fig. 3 External view of wire feeder

10. SPECIFICATION

10.1 Specification

Model		CMH-147
Roll method		4 rolls driving method
Applicable wire	Hard aluminum	3/64", 1/16"
	Mild aluminum	3/64", 1/16"
	Mild steel	0.035", 0.045"
	Stainless steel	
Wire feeding speed		Max. 59ft / min
Applicable wire reel	Shaft dia.	ϕ 1.97"
	Outer dia.	Max. ϕ 11.8"
	Width	4.06"
Applicable wire mass		Max. 55lb.
Approximate mass		48.4 lb.

10.2 Combination torch

Applicable current	For aluminum MIG	For stainless steel MIG
250A	WTCA-2501	WTCS-2501

10.3 Standard accessories

Description	Part No.	Q'ty	Remarks
Feed roll (.045", 1/16")	K1821G00	(2)	Built in body
Pressure roll (.045", 1/16")	K1821H00	(2)	Built in body
Welding cable (torch side)	U1997H00	1	0.093 in ² × 5.25ft
Welding cable (base metal side)	U1997J00	1	0.093 in ² × 5.90ft
Gas hose	U4450H00	1	9.84ft
Hexagon rod spanner		1	No. 6
Plug socket	U3396E00	1	2P

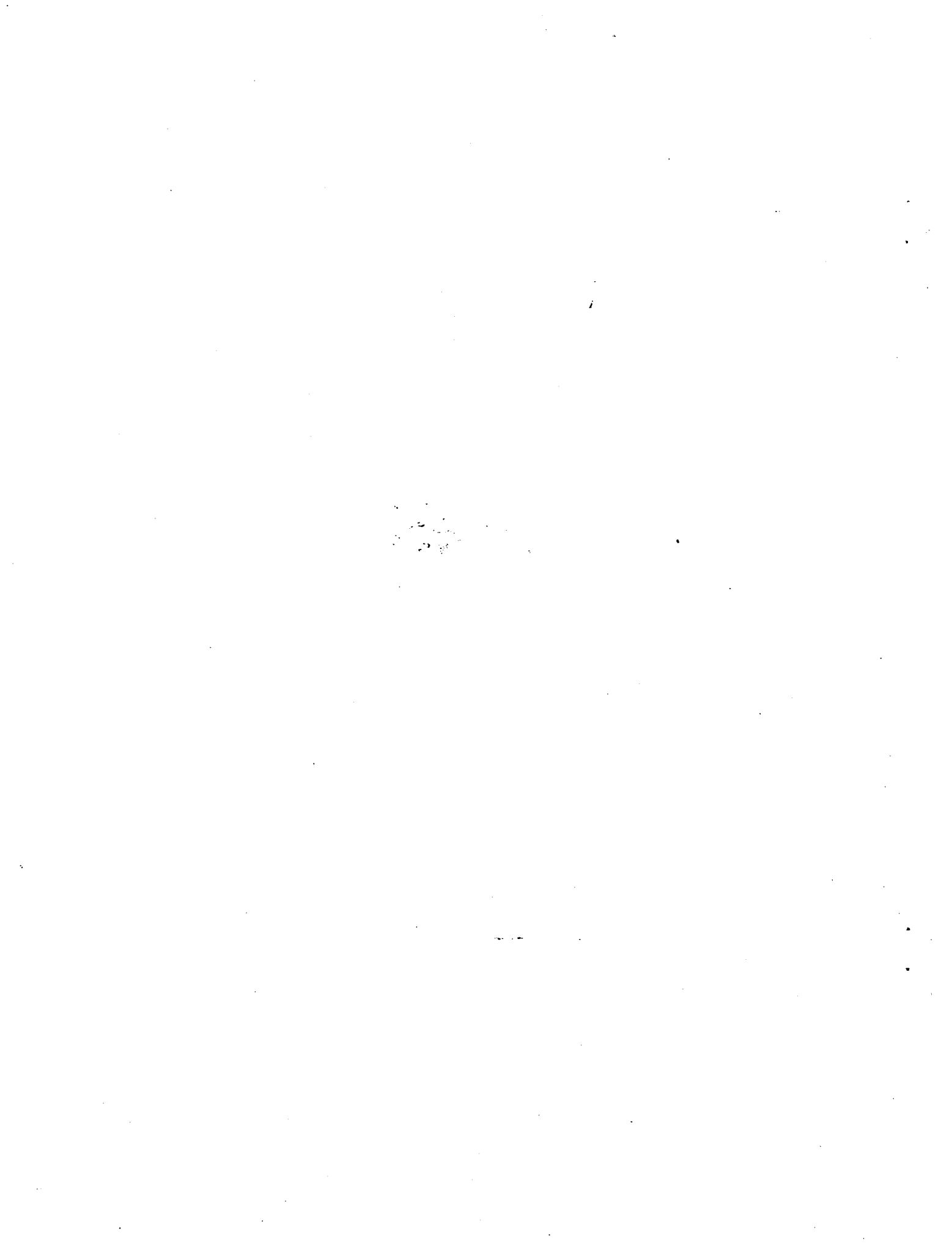



DAIHEN Corporation

5-1, Minamisenrioka, Settsu-shi, Osaka 566-0021, Japan

Phone : +81-6-317-2506, Fax : +81-6-317-2583

DAIHEN, INC.

5311 W.T. Harris BLVD West

Charlotte, North Carolina 28269, USA

Phone : +1-704-597-8240, Fax : +1-704-333-9790

DAIHEN EUROPE GmbH.

Krefelder Str. 677, D-41066 Monchengladbach, F.R. GERMANY

Phone : +49-2161-6949710, Fax : +49-2161-6949711

Upon contact, advise MODEL and MANUAL NO.

