



OWNER'S MANUAL
FOR
WIRE FEEDER
MODEL: CM-741 U5278

DO NOT DESTROY

IMPORTANT: Read and understand the entire contents of this manual, with special emphasis on the safety material throughout the manual, before installing, operating, or maintaining this equipment. This equipment and this manual are for use only by persons trained and experienced in the safety operation of welding equipment. Do not allow untrained persons to install, operate or maintain this equipment. Contact your distributor if you do not fully understand this manual.

DAIHEN Corporation WELDING PRODUCTS DIVISION

May 19, 2004

Upon contact, advise MODEL and MANUAL NO.

Notice : Machine export to Europe

This product does not meet the requirements specified in the EC Directives which are the EU safety ordinance that was enforced starting on January 1, 1995. Please make sure that this product is not allowed to bring into the EU after January 1, 1995 as it is.

The same restriction is also applied to any country which has signed the EEA accord.



Please ask us before attempting to relocate or resell this product to or in any EU member country or any other country which has signed the EEA accord.

TABLE OF CONTENTS

1. SAFETY INFORMATION.....	2
2. ARC WELDING SAFETY PRECAUTIONS.....	2
3. CHECKING OF QUANTITY OF THE ACCESSORIES.....	8
4. NAME OF PARTS.....	8
5. CARRYING AND INSTALLING OF THE WIRE FEEDER.....	9
6. CONNECTION PROCEDURE.....	10
7. WELDING PREPARATION.....	13
8. MAINTENANCE AND TROUBLESHOOTING.....	18
9. PARTS LIST.....	20
10. SPECIFICATIONS.....	27

1. SAFETY INFORMATION

The following safety alert symbols and signal words are used throughout this manual to identify various hazards and special instructions.

 WARNING	WARNING gives information regarding possible personal injury or loss of life.
 CAUTION	CAUTION refers to minor personal injury or possible equipment damage.

2. ARC WELDING SAFETY PRECAUTIONS

 WARNING	
ARC WELDING can be hazardous.	
<ul style="list-style-type: none"> ◆ ◆ ◆ ◆ 	<p>PROTECT YOURSELF AND OTHERS FROM POSSIBLE SERIOUS INJURY OR DEATH. Be sure to:</p> <ul style="list-style-type: none"> • Keep children away. • Keep pacemaker wearers away until consulting a doctor. <p>Read and understand the summarized safety information given below and the original principal information that will be found in the PRINCIPAL SAFETY STANDARDS.</p> <p>Have only trained and experienced persons perform installation, operation, and maintenance of this equipment.</p> <p>Use only well maintained equipment. Repair or replace damaged parts at once.</p>
ARC WELDING is safe when precautions are taken.	

2. ARC WELDING SAFETY PRECAUTIONS (continued)



ELECTRIC SHOCK can kill.

Touching live electrical parts can cause fatal shocks or severe burns. The electrode and work circuits are electrically live whenever the output is on. The power line and internal circuits of this equipment are also live when the line disconnect switch is on. When arc welding all metal components in the torch and work circuits are electrically live.

1. Do not touch live electrical parts.
2. Wear dry insulating gloves and other body protection that are free of holes.
3. Insulate yourself from work and ground using dry insulating mats or covers.
4. Be sure to disconnect the line disconnect switch before installing, changing torch parts or maintaining this equipment.
5. Properly install and ground this equipment according to its Owner's Manual and national, state, and local codes.
6. Keep all panels and covers of this equipment securely in place.
7. Do not use worn, damaged, undersized, or poorly spliced cables.
8. Do not touch electrode and any metal object if POWER switch is ON.
9. Do not wrap cables around your body.
10. Turn off POWER switch when not in use.



ARC RAYS can burn eyes and skin: FLYING SPARKS AND HOT METAL can cause injury. NOISE can damage hearing.

Arc rays from the welding process produce intense heat and strong ultraviolet rays that can burn eyes and skin.

Noise from some arc welding can damage hearing.

1. Wear face shield with a proper shade of filter (See ANSI Z 49.1 listed in PRINCIPAL SAFETY STANDARDS) to protect your face and eyes when welding or watching a welder work.
2. Wear approved safety goggles. Side shields recommended.
3. Use protective screens or barriers to protect others from flash and glare: warn others not to look at the arc.
4. Wear protective clothing made from durable, flame-resistant material (wool and leather) and foot protection.
5. Use approved earplugs or earmuffs if noise level is high.
Chipping and grinding can cause flying metal. As welds cool, they can throw off slag.
6. Wear approved face shield or safety goggles. Side shields recommended.
7. Wear proper body protection to protect skin.

2. ARC WELDING SAFETY PRECAUTIONS (continued)

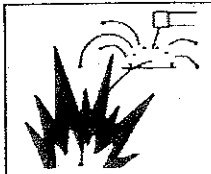

WELDING can cause fire and explosion.

Sparks and spatter fly off from the welding arc. The flying sparks and hot metal, spatter, hot base metal, and hot equipment can cause fire and explosion. Accidental contact of electrode or welding wire to metal object can cause sparks, overheating, or fire.

1. Protect yourself and others from flying sparks and hot metals.
2. Do not weld where flying sparks can strike flammable material.
3. Remove all flammables within 10m (33ft) of the welding arc. If this is not possible, tightly cover them with approved covers.
4. Be alert that welding sparks and hot metals from welding can easily pass through cracks and openings into adjacent areas.
5. Watch for fire, and keep a fire extinguisher nearby.
6. Be aware that welding on a ceiling, floor, bulkhead, or partition can ignite a hidden fire.
7. Do not weld on closed containers such as tanks or drums.
8. Connect base metal side cable as close to the welding area as possible to prevent the welding current from traveling along unknown paths and causing electric shock and fire hazards.
9. Remove stick electrode from holder or cut off welding wire at contact tip when not in use.
10. Does not use the welding power source for other than arc welding.
11. Wear oil-free protective garments such as leather gloves, a heavy shirt, cuffless trousers, boots, and a cap.
12. A loose cable connection can cause sparks and excessive heating.
13. Tighten all cable connections.
14. When there is an electrical connection between a work piece and the frame of wire feeder or the wire reel stand, arc may be generated and cause damage by a fire if the wire contacts the frame or the work piece.



FUMES AND GASES can be hazardous to your health.

Arc welding produce fumes and gases. Breathing these fumes and gases can be hazardous to your health.

1. Keep your head out of the fumes. Do not breathe the fumes.
2. Ventilate the area and/or use exhaust at the arc to remove welding fumes and gases.
3. If ventilation is poor, use an approved air-supplied respirator.
4. Read the Material Safety Data Sheets (MSDS) and the manufacturer's instructions on metals, consumables, coatings, and cleaners.
5. Do not weld or cut in locations near degreasing, cleaning, or spraying operations. The heat and rays of the arc can react with vapors to form highly toxic and irritating gases.
6. Work in a confined space only if it is well ventilated, or while wearing an air-supplied respirator. Shielding gases used for welding can displace air causing injury or death. Be sure the breathing air is safe.

2. ARC WELDING SAFETY PRECAUTIONS (continued)



CYLINDER can explode if damaged.

A shielding gas cylinder contains high-pressure gas. If damaged, a cylinder can explode. Since gas cylinders are normally part of the welding process, be sure to treat them carefully.

1. Use only correct shielding gas cylinders, gas regulator, hoses, and fittings designed for the specific application; maintain them in good condition.
2. Protect compressed gas cylinders from excessive heat, mechanical shock, and arcs.
3. Keep the cylinder upright and securely chained to a stationary support or a rack to prevent falling or tipping.
4. Keep cylinders away from any welding or other electrical circuit.
5. Never touch cylinder with welding electrode.
6. Read and follow instructions on compressed gas cylinders, associated equipment, and the CGA publication P-1 listed in PRINCIPAL SAFETY STANDARDS.
7. Turn face away from valve outlet when opening cylinder valve.
8. Keep protective cap in place over valve except when gas cylinder is in use or connected for use.
9. Do not disassemble or repair the gas regulator except for the person authorized by the manufacturer of them.



Rotating parts may cause injuries. Be sure to observe the following.

If hands, fingers, hair or clothes are put near the fan's rotating parts or wire feeder's feed roll, injuries may occur.

1. Do not use this equipment if the case and the cover are removed.
2. When the case is removed for maintenance/inspection and repair, certified or experienced operators must perform the work. Erect a fence, etc. around this equipment to keep others away from it.
3. Do not put hands, fingers, hair or clothes near the rotating fans or wire feed roll.

2. ARC WELDING SAFETY PRECAUTIONS (continued)

	<p>ARC WELDING work areas are potentially hazardous.</p>
<p>FALLING or MOVING machine can cause serious injury.</p> <ul style="list-style-type: none">◆ When hanging the welding power source by a crane, do not use the carrying handle.◆ Put the welding power source and wire feeder solidly on a flat surface.◆ Do not pull the welding power source across a floor laid with cables and hoses.◆ Do not put wire feeder on the welding power source.◆ Do not put the welding power source and wire feeder where they will pit or fall. <p>WELDING WIRE can cause puncture wounds.</p> <ul style="list-style-type: none">◆ Do not press gun trigger until instructed to do so.◆ Do not point gun toward any part of the body, other people, or any metal when threading welding wire.	

PRINCIPAL SAFETY STANDARDS

Arc welding equipment – Installation and use, Technical Specification IEC 62081, from International Electro technical Commission

Arc welding equipment Part 1: Welding power sources IEC 60974-1, from International Electro technical Commission

Safety in Welding and Cutting, ANSI Standard Z49.1, from American Welding Society.

Safety and Health Standards, OSHA 29 CFR 1910, from Superintendent of Documents, U.S. Government Printing Office.

Recommended Practices for Plasma Arc Cutting, American Welding Society Standard AWS C5.2, from American Welding Society.

Recommended Safe Practices for the Preparation for Welding and Cutting of Containers That Have Held Hazardous Substances, American Welding Society Standard AWS F4.1, from American Welding Society.

National Electrical Code, NFPA Standard 70, from National Fire Protection Association.

Safe Handling of Compressed Gases in Cylinders, CGA Pamphlet P-1, from Compressed Gas Association.

Code for Safety in Welding and Cutting, CSA Standard W117.2, from Canadian Standards Association, Standards Sales.

Safe Practices For Occupation And Educational Eye And Face Protection, ANSI Standard Z87.1, from American National Standards Institute.

Cutting And Welding Processes, NFPA Standard 51B, from National Fire Protection Association.

NOTE: The codes listed above may be improved or eliminated. Always refer to the updated codes.

3. CHECKING OF QUANTITY OF THE ACCESSORIES

Make sure that you have the items below before you use the wire feeder.

Wire feeder

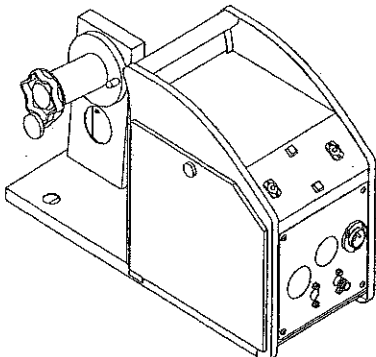
Wire feeder		Accessory		
	No.	Description	Specification	Quantity
	①	Gas hose (9.8ft [3m])	K5430A00	1
	②	Hose cover	U1997C03	2
	③	Cable joint	4734-027	1

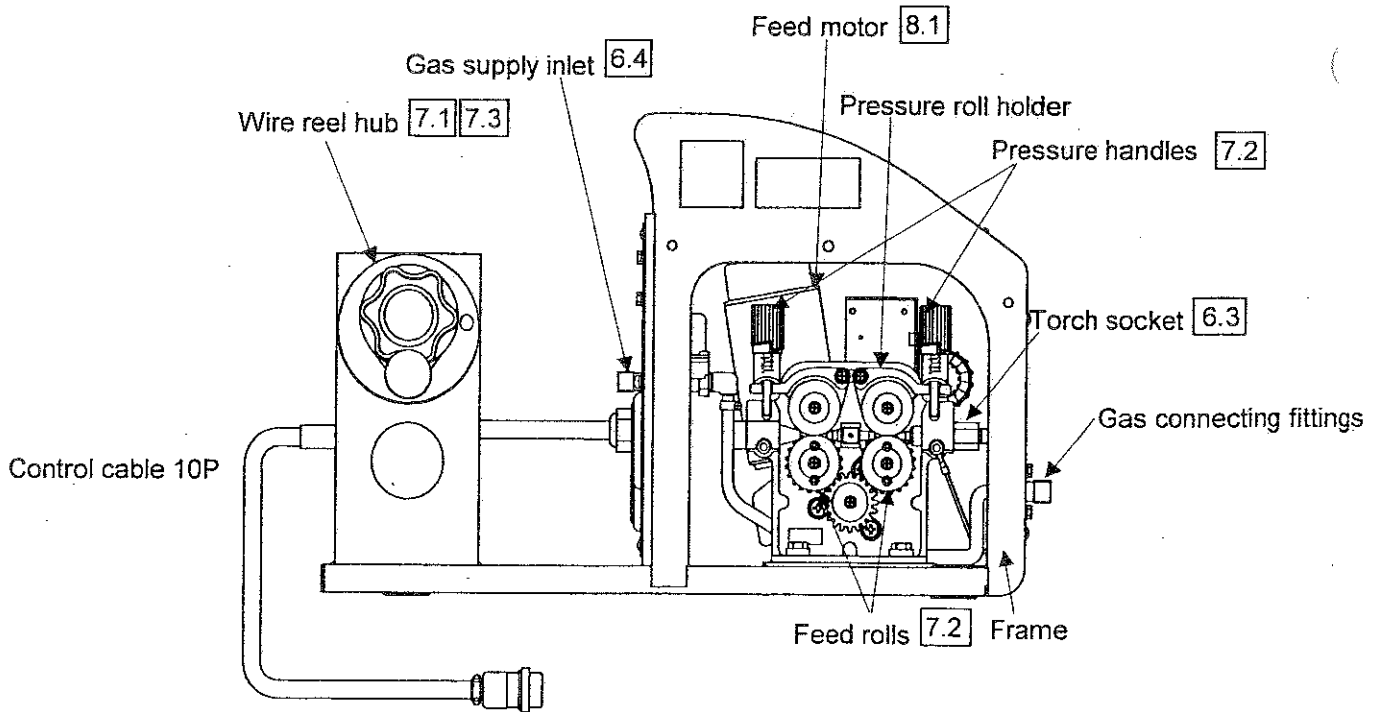

4. NAMES OF PARTS

Refer to the section indicated in for details.





5. CARRYING AND INSTALLING OF THE WIRE FEEDER

5.1 Transportation

 WARNING	
Observe the following to avoid damage to the wire feeder or physical injury when carrying the equipment.	
	<ul style="list-style-type: none"> ● Do not touch the charging parts inside or outside of the wire feeder. ● Disconnect the welding power source by turning off the line disconnect switch in the power box to avoid an electric shock before carrying the equipment.
	<ul style="list-style-type: none"> ● Be sure to detach the wire reel from the fire feeder before lifting the equipment to the high places by a crane.

5.2 Installation

 WARNING	
When installing the wire feeder, follow the instructions below to avoid occurrence of fires during welding and physical damage by fume gas.	
	<ul style="list-style-type: none"> ● Do not place the welding machine near combustible materials and flammable gas. ● Remove combustible materials to prevent dross coming into contact with combustible objects. If that not possible, cover them with noncombustible covers.
	<ul style="list-style-type: none"> ● To avoid gas poisoning and danger of suffocation, wear a gas mask or adequately ventilate when using the welding machine in the place regulated by a local law. ● To prevent disorder or poisoning caused by fume, wear a gas mask or weld at a partial exhaust facility approved by the local regulation. ● Adequately ventilate or wear a gas mask when using the welding machine in a tank, a boiler, a hold of a ship, because heavier gas such as carbon dioxide or argon gases are drifting there. ● When using the welding machine at a narrow space, comply with a trained supervisor's directions. And be sure to wear a gas mask. ● Do not operate the welding machine near the place where degreasing, cleansing, and spraying are performed. Otherwise, poisonous gas may be generated. ● Be sure to wear a gas mask or adequately ventilate when welding a coating steel plate. (Poisonous gas and fume may be generated.) ● Do not place the welding power source, wire feeder, torch, and control cable (including the extension cable) in an area where the equipment can become wet.

INSTALLATION PLACE

Follow the instructions below when selecting an installation place of the wire feeder.

- Do not install the wire feeder in the indoor place subject to direct sunlight and rain.
- Install the wire feeder in the place where the ambient temperature is between -10 °C and +40 °C.
- Do not place the welding power source, wire feeder, torch, and control cable (including the extension cable) in an area where the equipment can become wet.
- Use a wind shield to protect arc from a wind blow when welding on a windy day.

6. CONNECTION PROCEDURE

	CAUTION
Follow the instructions below to avoid electric shock.	
<p>* Do not touch the charging parts, otherwise this will result in fatal shock and severe burns.</p> <ul style="list-style-type: none"> ● Do not touch the charging parts of the welding machine. ● Have a qualified electric engineer ground the case of the welding power source and the base metal or jig electrically connected, following a local law. ● Disconnect the welding power source by turning off the line disconnect switch in the power box to avoid an electric shock before grounding the welding power source or base metal and connecting the cables or hoses. ● Do not use a cable with lack of capacity or a cable seriously damaged. ● Tighten and insulate the connections of cables. ● Firmly attach the cover of the welding machine after connection of the cables. ● Do not place the welding power source, wire feeder, torch, and control cable (including the extension cable) in an area where the equipment can become wet. 	

6.1 Connecting to the Welding Power Source and to the Gas regulator

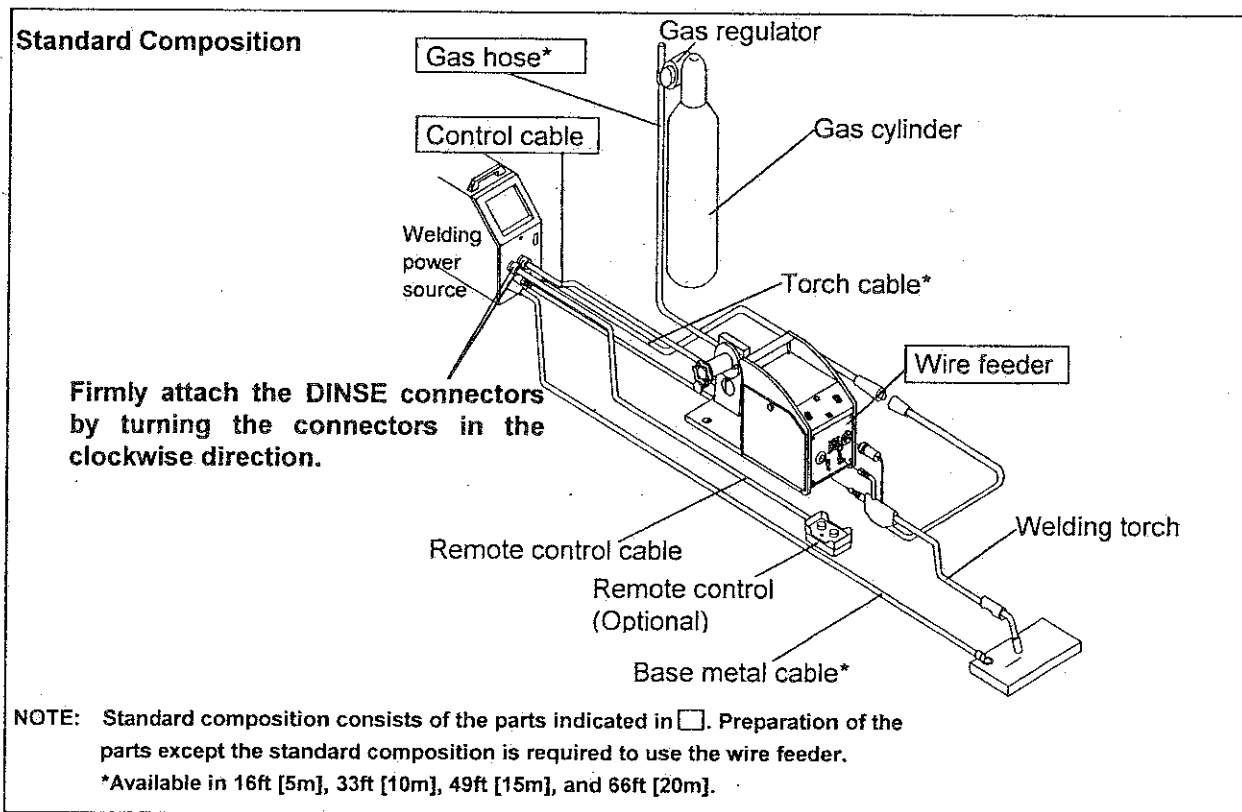

Follow the steps below to connect to the welding power source and to the gas regulator.

1. Ground the base metal (if required by local laws or codes).
2. Connect between the negative output terminal for the base metal and the base metal with the base metal cable.
3. Attach the torch cable to the positive output terminal of the welding power source.
4. Plug the control cable for the wire feeder (10P) into the wire feeder socket on the welding power source.
5. Attach the gas hose to the gas supply inlet on the wire feeder.
6. Connect the welding torch to the wire feeder.
7. Connect the torch cable to the power cable of the welding torch.

6. CONNECTION PROCEDURE (continued)

6.2 Connection of the Torch Cable

WARNING
<p>* Touching the charging parts may result in fatal electric shock and severe burns.</p> <ul style="list-style-type: none"> ● Do not touch the charging parts of the welding machine. ● Have a qualified electric engineer ground the case of the welding power source and the base metal or jig electrically connected in accordance with a local law. ● Disconnect the welding power source by turning off the line disconnect switch in the power box to avoid an electric shock before the welding power source or base metal and connecting the cables or hoses. ● After connecting the cables, cover the power source with the cover or case. ● When using the welding machine in such a humid environment as construction site, on the steel plate, or on steel structure, install a leakage breaker.

CAUTION								
<p>● Use the proper torch cable that matches the welding current.</p> <table border="1" style="margin: 10px auto; border-collapse: collapse; text-align: center;"> <thead> <tr> <th style="padding: 5px;">Welding current</th> <th style="padding: 5px;">Cable thickness</th> </tr> </thead> <tbody> <tr> <td style="padding: 5px;">200 A</td> <td style="padding: 5px;">AWG 1 [38mm²] or more</td> </tr> <tr> <td style="padding: 5px;">350 A</td> <td style="padding: 5px;">AWG 0 [60mm²] or more</td> </tr> <tr> <td style="padding: 5px;">500 A</td> <td style="padding: 5px;">AWG 3/0 [80mm²] or more</td> </tr> </tbody> </table> <p>* When performing pulse welding using a 56ft [17m] or more cable, use the thicker cable by one rank.</p>	Welding current	Cable thickness	200 A	AWG 1 [38mm ²] or more	350 A	AWG 0 [60mm ²] or more	500 A	AWG 3/0 [80mm ²] or more
Welding current	Cable thickness							
200 A	AWG 1 [38mm ²] or more							
350 A	AWG 0 [60mm ²] or more							
500 A	AWG 3/0 [80mm ²] or more							

6.3 Connection of the welding torch

1. Remove the guide adapter from the wire feeder, insert the outlet guide into the guide adapter and attach the guide adapter to the conduit of the welding torch. Use proper sized outlet guide adjusted to the wire size.

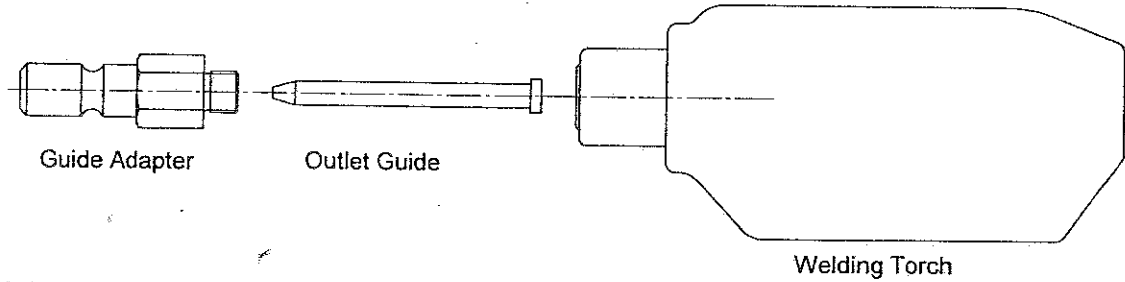

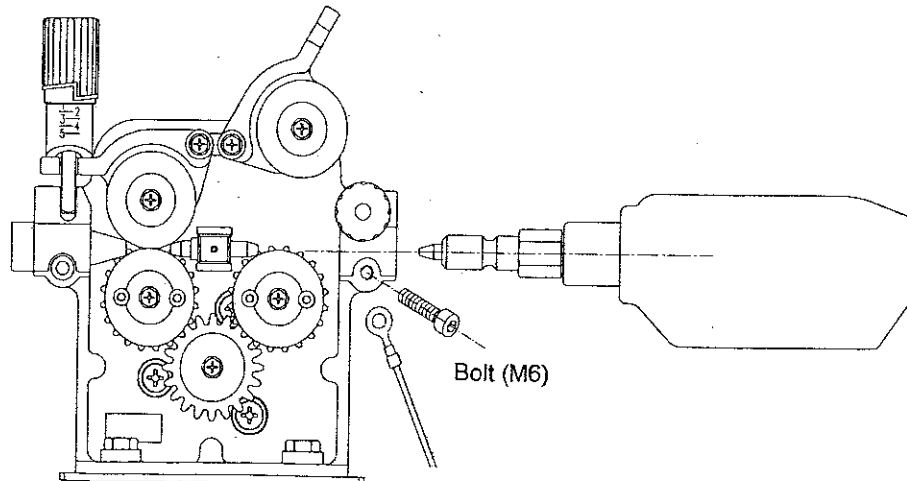

2. Insert the guide adapter to the



6. CONNECTION PROCEDURE (continued)

6.4 Connection of the Gas Hose

 WARNING	
	<ul style="list-style-type: none"> ● You may suffer from danger of suffocation caused by lack of oxygen when shield gas keeps drifting in a closed place. Be sure to turn off the shield gas at the main when the welding power source is not in use.

 WARNING	
<ul style="list-style-type: none"> ● Be sure to connect the gas hose after fixing to the stand, as physical injuries may result from falling down of gas cylinder. ● Attach a proper gas regulator to the gas cylinder. Failure to observe the demand may result in physical injuries. The gas regulator for high pressure gas must be used. 	

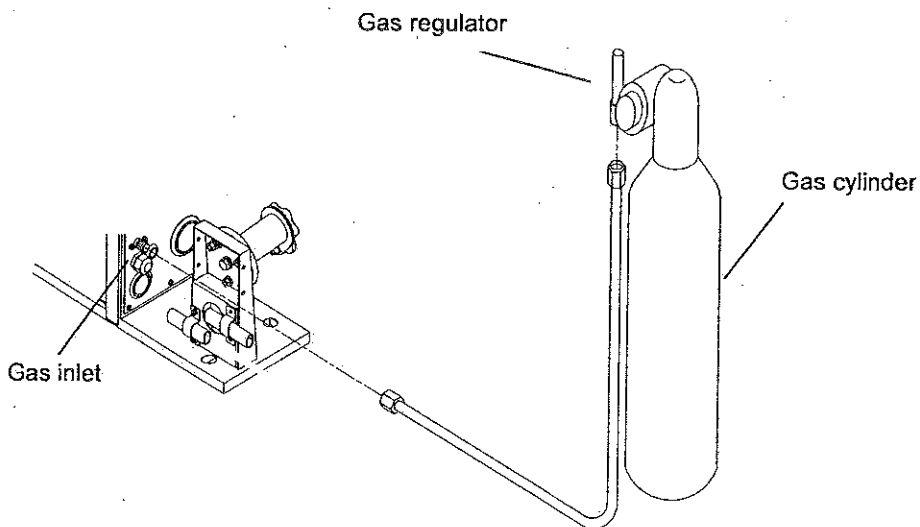

Follow the steps below to connect to the gas regulator.

1. Firmly connect the gas hose to the gas supply inlet located on the rear side of the wire feeder.
2. Mount the gas regulator on the gas cylinder by tightening the nut for attaching the gas cylinder.
3. Connect the gas hose to the gas supply outlet on the gas regulator.

NOTE: Firmly tighten the nuts using a monkey wrench, etc. to connect the gas hose and gas regulator.

7. WELDING PREPERATION

7.1 Fitting of Wire

1. Loosen the screw to clamp the cap knob.
2. Detach the cap knob from the wire reel shaft.
3. Mount the wire reel on the wire reel shaft.

NOTE: Put the wire reel stop pin into the wire reel stop hole.

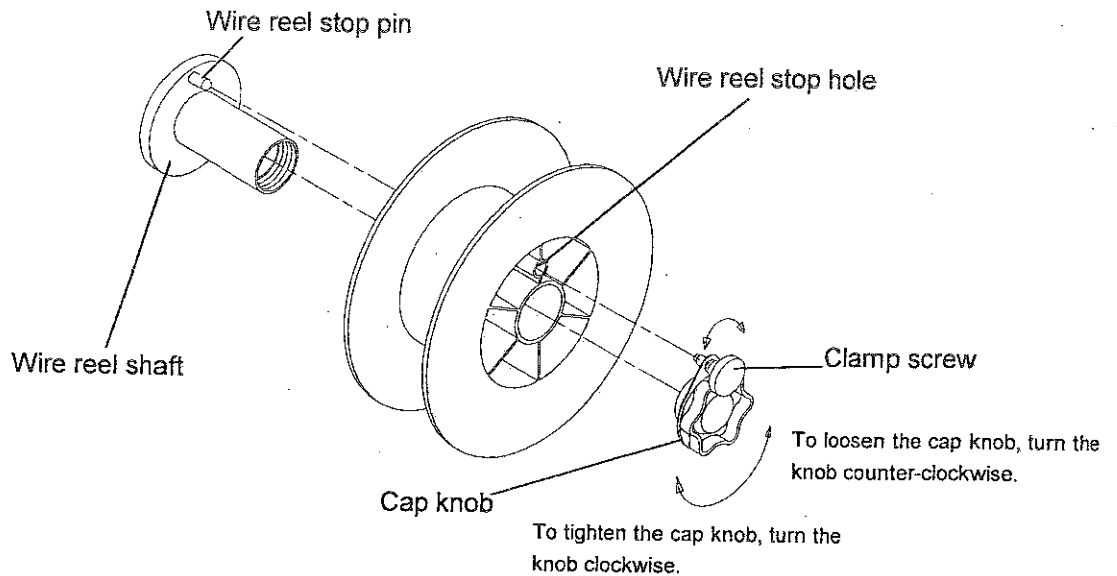

4. Firmly tighten the cap knob.
5. Align the hole in the cap knob with the wire reel stop hole, then fasten the clamp screw to prevent the cap knob from dropping.

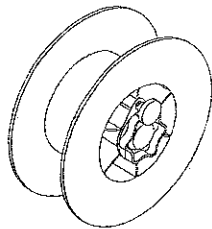

 CAUTION
<p>● When hanging the wire feeder, firmly fix the cap knob and clamp screw to prevent the device from dropping.</p>

6. Bring down the pressure handle, then raise the pressure roll holder.
7. After pulling out the wire, thread it from the pilot to outlet guide through the center guide.
8. Return the pressure reel holder first, the pressure handle.

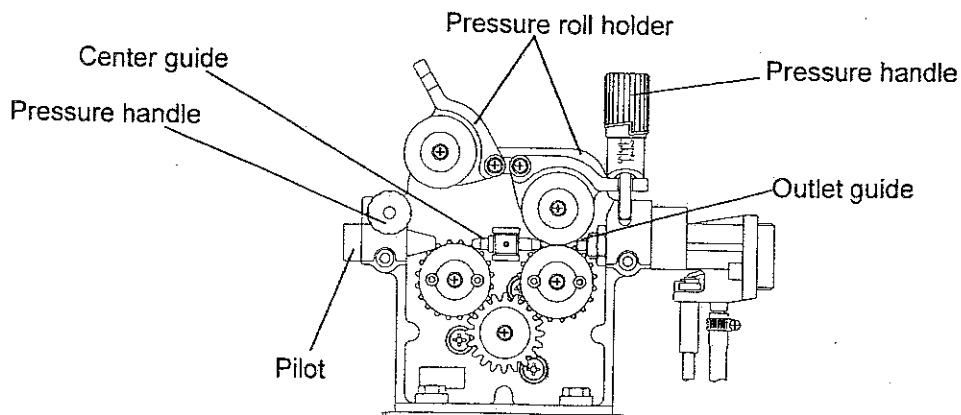

7. WELDING PREPERATION (continued)

7.2 Mounting of the Feed Roll

Confirmation of the wire size marked on the feed roll

Use the right groove of the feed roll for the wire size.

The feed roll of ϕ 0.045in [1.2mm] wire size is mounted on the CM-741 wire feeder when shipping.

Groove for 0.045in
[1.2mm] wire size

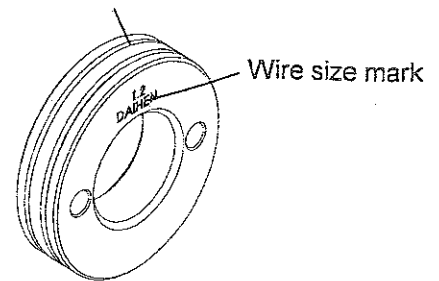
**Replacement of the feed roll**

1. Remove the hexagon socket cap screws fixing the feed roll.
2. Bring down the pressure handle, and then lift the pressure roll holder.
3. Separate the feed roll from the wire feeder by pulling out the feed roll.
4. Mount the new feed roll, with the wire size marked on the wire feeder facing out.

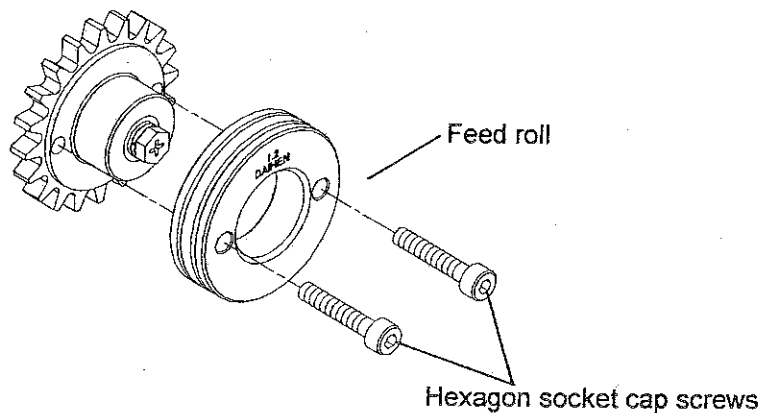

• For aluminum welding

1. Remove the pressure roll.
2. Change the center guide for aluminum.
3. Attach the middle gear and feed roll for aluminum.
4. Attach the wire straightener.

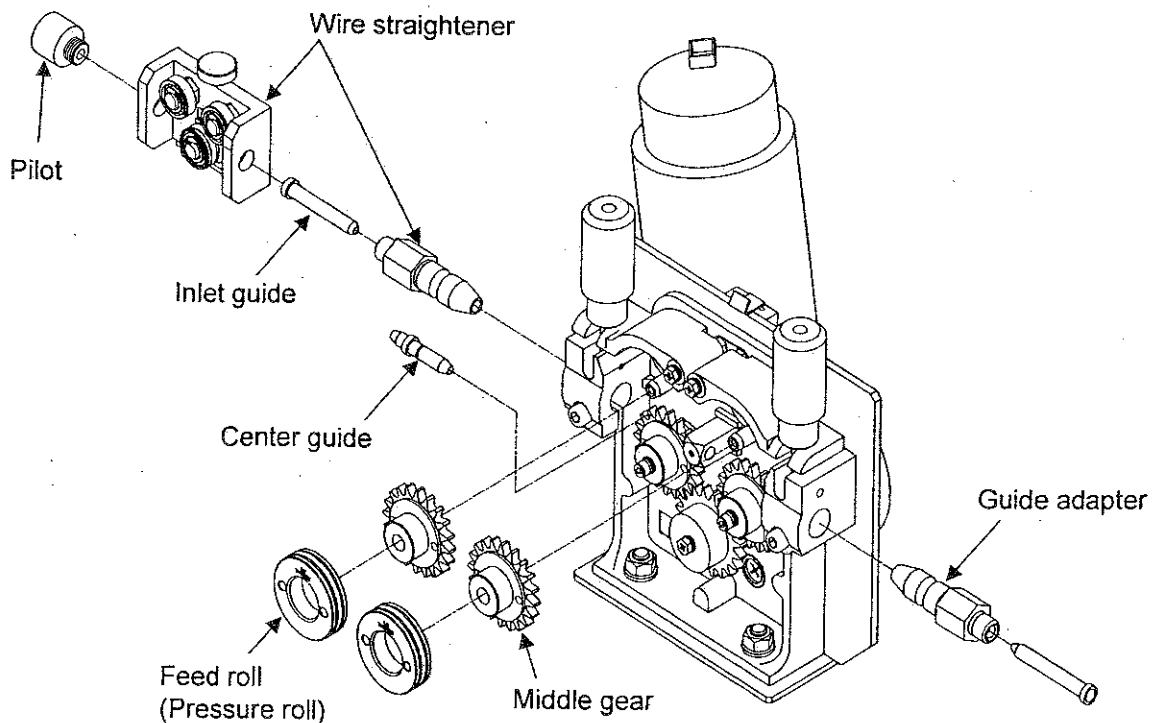

7. WELDING PREPERATION (continued)

Adjusting of the wire pressure and straightener

- Set to the proper wire pressure for the wire type by turning the pressure handle.
- The numeral on the pressure scale set with the right pressure handle should be correspond to the one set with the left pressure handle.

Recommended wire pressure adjustment

Wire diameter	Wire pressure scale	
	Solid wire	Flux cored wire
ϕ 1/16in [1.6mm], ϕ 5/64in [2.0mm]	4 - 5	3 - 4
ϕ 0.045in [1.2mm], ϕ 0.052in [1.4mm]	3 - 4	2 - 3
ϕ 0.035in [0.9mm], [ϕ 1.0mm]	2 - 3	
ϕ 0.030in [0.8mm]	1 - 2	

7.3 Adjusting of the wire reel hub

After performing inching operation, take care to adjust the brake of the wire reel hub to prevent the wire from going too slack. The brake has been properly adjusted before shipment. Therefore, readjustment of the brake is not required for welding in standard welding conditions.



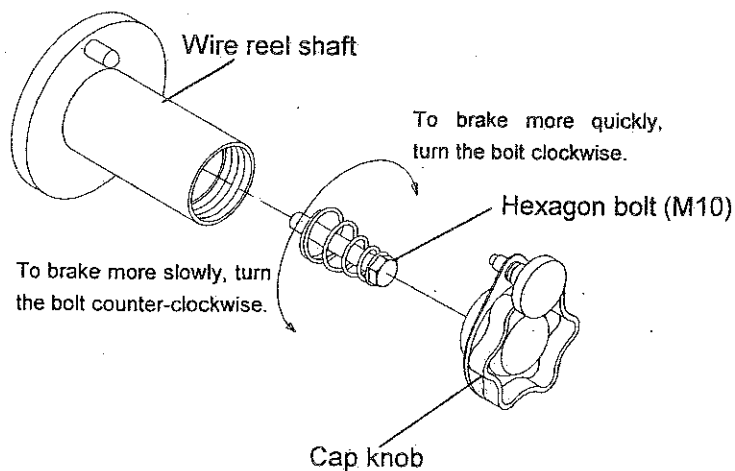

How to adjust the wire reel hub

1. Detach the cap knob from the wire reel shaft.
2. Adjustment of the brake can be achieved by turning the hexagon bolt (M10).







7. WELDING PREPERATION (continued)

7.4 Feeding Wire by Inching Operation

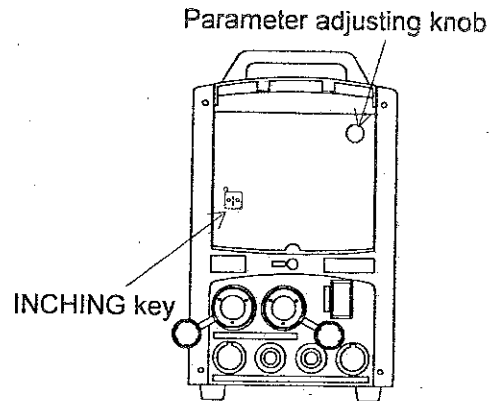
 WARNING	
	<ul style="list-style-type: none"> ● Do not look into the tip hole to check for the rate of wire feeding while inching.
 CAUTION	
	<ul style="list-style-type: none"> ● Keep away your hands, fingers, hair or clothes from the rotating parts of the feed roll, etc. to prevent you from being caught into the rotating parts while inching.

After straightening the welding torch, feed the wire by pressing the INCHING key. (the INCHING lamp located at the upper right of the INCHING key lights up). When the wire appears from the end of the torch, press the INCHING key again (the INCHING lamp goes out). Cut the wire at about 0.4in [10mm] from the end of the tip. Wire feed speed can be adjusted by turning the parameter adjusting knob.



 WARNING	
Touching the charging parts may cause fatal electric shocks and burns.	
	<ul style="list-style-type: none"> ● Never touch the charging parts in the wire and wire feeder. The parts indicated as  in the figure below are the charging parts during welding.

7. WELDING PREPERATION (continued)

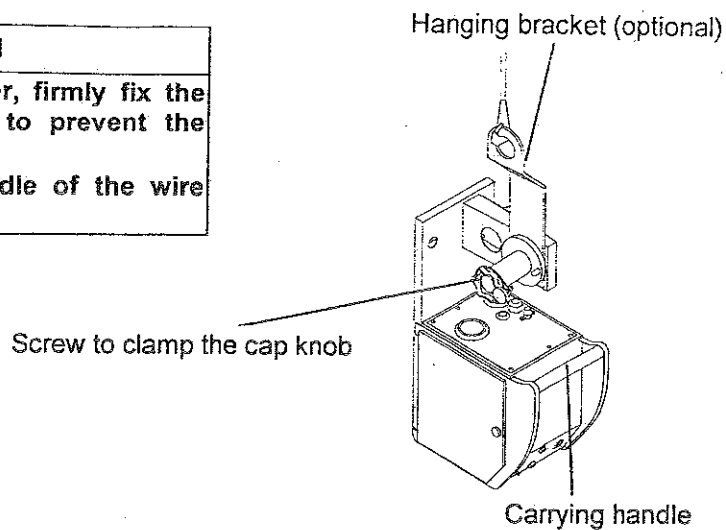

7.5 Hanging the Wire Feeder

 CAUTION	
●	When hanging the wire feeder, firmly fix the cap knob and clamp screw to prevent the device from dropping.
●	Do not use the carrying handle of the wire feeder to hang the wire feeder.



8. MAINTENANCE AND TROUBLESHOOTING

8.1 Carrying Out Maintenance

 WARNING	
	<ul style="list-style-type: none"> ● Do not touch the charging parts inside or outside of the wire feeder. ● Disconnect the welding power source by turning off the line disconnect switch in the power box to avoid an electric shock before carrying the equipment.

No.	Problem	Cause	Solution
1	Wire gets deformed.	Wire pressure is too strong.	Refer to "Recommended wire adjustment" in Section 7.2.
		Feed roll of wrong wire size is used.	Replace it with the feed roll of proper wire size.
		Feed roll and pressure roll are worn.	Replace the feed roll and the pressure roll with a new ones.
2	Wire is not fed.	Poor contact or breakdown in the control cable.	Check the socket. Check the cables and replace with new ones if necessary.
		Poor contact or breakdown in the encoder cable	
		Poor contact or breakdown in the voltage detection cable	
		Trouble with the motor	Replace the motor with a new one.
		Wire pressure is too weak.	Refer to "Recommended wire adjustment" in Section 7.2.
		Dust and chip are accumulated on the outlet guide and on the feed roll.	Remove the dust and chip.
3	Pressure roll does not rotate smoothly.	Failure of the pressure roll holder.	Replace it with a new one.
4	Shield gas is not supplied when pressing the torch switch.	The discharge valve of the gas cylinder is closed.	Open the valve.
		Lack of gas pressure in the gas cylinder	Check gas pressure.
		Failure of gas solenoid valve	After checking the gas solenoid valve, replace it with new one.
5	Shield gas supply does not stop.	Failure of gas solenoid valve	Check the socket. Check the cables and replace with new one.
6	Defective gas hoses	Crack in the gas hose	Replace them with new one.
7	Wire is not fed smoothly through the wire reel.	Adjustment of the brake is either too strong or too weak.	Refer to "Adjustment of the wire reel hub" in Section 7.3.

8. MAINTENANCE AND TROUBLESHOOTING (continued)

< Schematic Diagram >

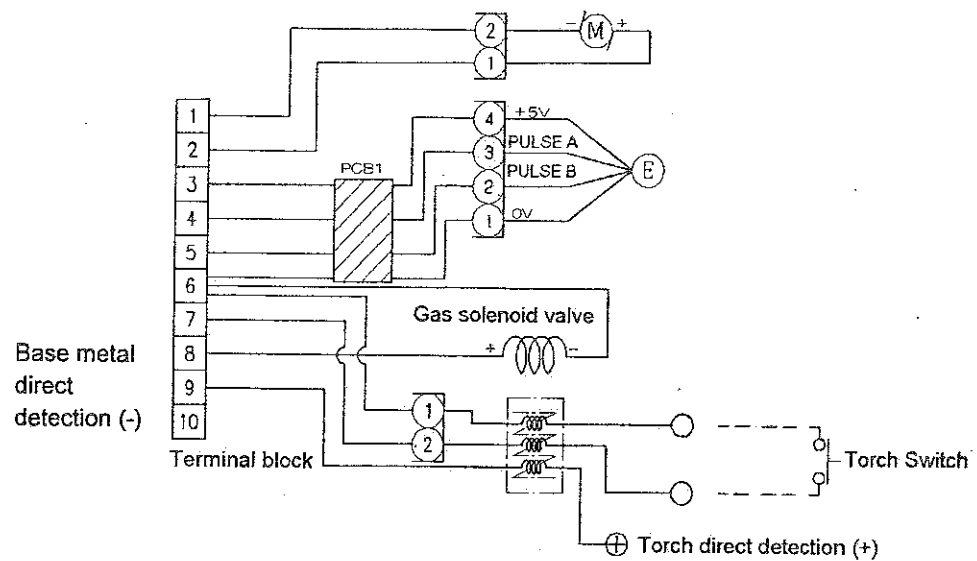

⚠ CAUTION

- Never attempt to disassemble the feed motor. This may result in damage to the wire feeder.
- Never check the amount of brushing friction or replace the brush.

Service life of the brush varies depending on ambient temperature and welding condition, etc., but normally the service life is about 4,000 hours. (If the machine is operated for six hours a day, the service life of the brush will be about two years). Periodical replacement of the feed motor is recommended.

9. PARTS LIST

9.1 Main body and Wiring

- Please contact your local dealer to order parts. (See the back cover for telephone and fax numbers, and mailing addresses.)

Ref. No.	Part number	Description	Q'ty	Remarks
	CM-7401			
1	U5185U00	Frame	1	Assembly
2	K970H90	Strike	2	
3	4739-013	Support	2	
4	U5185C01	Cover	1	With coating
5	U5185C02	Screw with knob	1	
5-1	3361-219	Washer	2	
6	U5185C03	Side plate	1	With coating and a screen
7	U5209C01	Rear cover	1	With coating
7-1	4739-490	Grommet with film	1	
7-2	4739-491	Grommet with film	1	
7-3	4739-489	Grommet with film	1	
8	U5278C02	Panel	1	With coating and a screen
9	U5209B00	Wire feeder	1	With a feed motor
10	U5278J01	Guide Adapter	1	
11	U5185J09	Power terminal block	1	
12	U5185J04	Terminal block bracket	1	
13	4739-492	Terminal block	1	
14	U5185X00	Encoder cable	1	Assembly
15	U5185F00	Motor cable	1	Assembly
16	U5185E00	Control cable	1	Assembly
16-1	4730-422	Metal socket	(1)	
17	4739-494	Wire reel hub	1	
18	U5185J07	Plate	1	
19	U5185J08	Clamp screw	1	
19-1	3361-405	E-snap ring	1	E-4
20	U5191B00	Common mode coil	1	Assembly
21	U5185J01	Cable clamp	1	
22	U1997C02	Hose clamp	1	
23	U1997C03	Hose cover	2	
24	U5185J05	Wire reel cover	1	
25	4730-002	Receptacle	1	2P

9. PARTS LIST (continued)

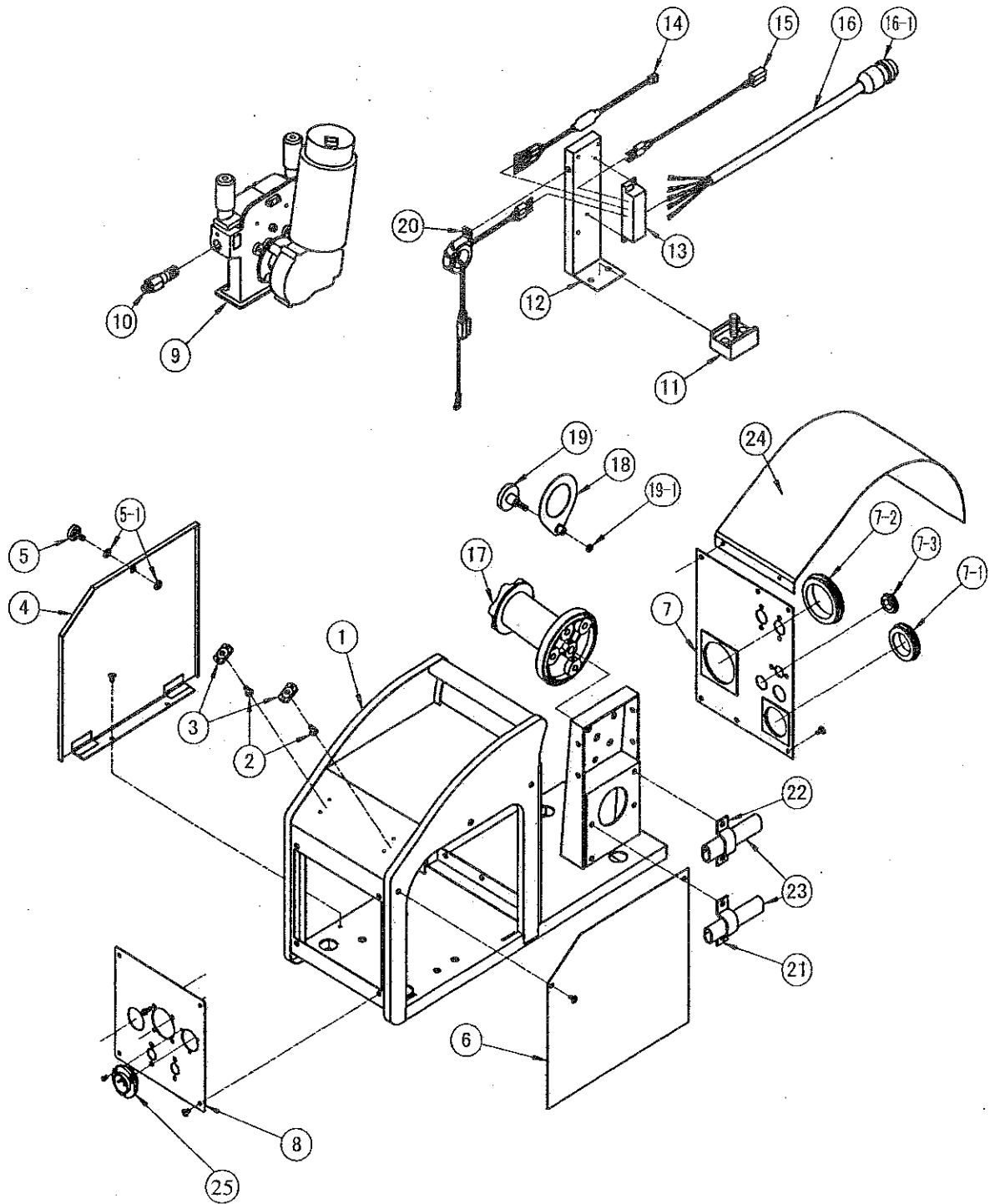

Fig. 1 Main Body and Wiring Assembly

9. PARTS LIST (continued)

9.2 Wire Feeder

Ref. No.	Part number	Description	Q'ty	Remarks
1	U5209B01	Bracket	1	
1-1	-	Hexagon socket cap screw	2	M6 x 25
2	U5185B08	Coil spring	1	
3	U5185B02	Pressure roll holder pin	2	
4	U5185S00	Pressure roll holder (R)	1	Assembly
5	U5185T00	Pressure roll holder (L)	1	Assembly
6	K5439C00	Pressure roll	2	Assembly
7	U5158B03	Driving roll shaft	2	
8	U5185P00	Gear	2	Assembly
9	U5439B12	Feed roll (0.9-1.0/1.2)	2	
9-1	-	Hexagon socket cap screw	4	M4 x 16
9-2	-	Bolt	4	M4 x 10
10	U5185B04	Guide block	1	
11	U5185B05	Center guide	1	
12	4802-206	Feed motor	1	
13	U5185B06	Insulating board	1	
14	U3971B04	Insulating bush	3	
14-1	-	Flat head screw	3	M6 x 20
15	U5185Q00	Drive gear	1	
16	U5185B09	Pressure spring holder	2	
17	U5185B12	Compression spring	2	
18	U5185B10	Pressure handle	2	
19	U5185B11	Pressure bolt	2	
19-1	-	Spring pin	2	2.5 x 14
20	U5185J06	Pilot	1	
21	U5185B13	Insulating bush	2	
21-1	-	Hexagon bolt	2	M8 x 30
22	U5185B14	Insulating board	1	

9.PARTS LIST (continued)

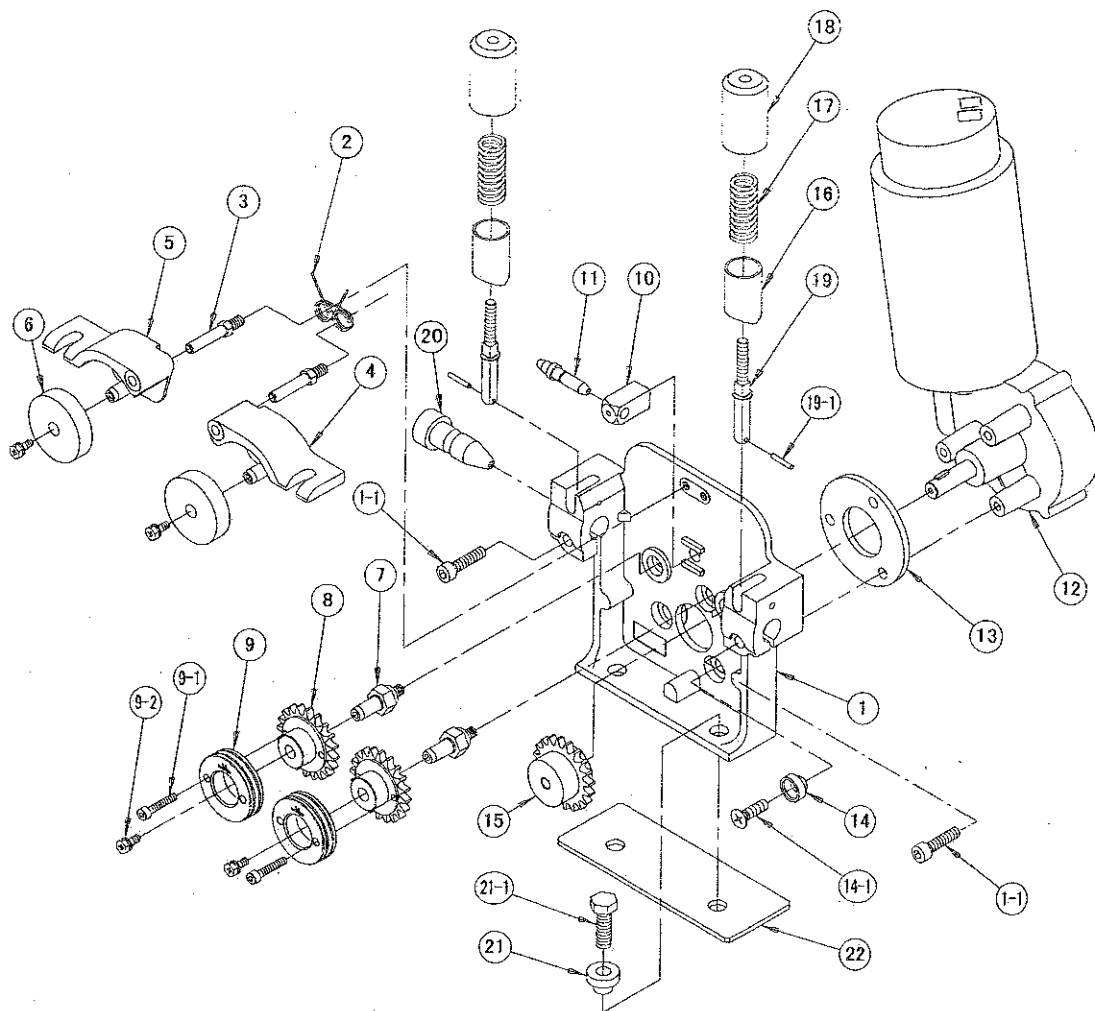

Fig. 2 Wire Feeder Assembly

9.3 Central Adapter

Ref. No.	Part number	Description	Q'ty	Remarks
1	4813-001	Gas solenoid valve	1	W-31156
2	U4179D01	Hose elbow	1	
3	U1997D01	Gas connector	1	
4	U1997D02	Flange	1	

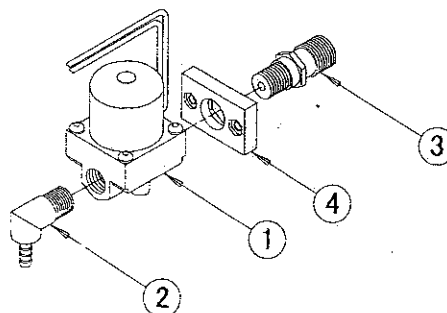

Fig. 3 Gas Piping Assembly

9. PARTS LIST (continued)

9.5 Optional Accessory

(1) Extension cable/hose
Control cable (10P)

	Cable length			
	16ft [5m]	33ft [10m]	49ft [15m]	66ft [20m]
Model	BKCPJ-1005	BKCPJ-1010	BKCPJ-1015	BKCPJ-1020

Gas hose

	Cable length			
	16ft [5m]	33ft [10m]	49ft [15m]	66ft [20m]
Model	BKGG-0605	BKGG-0610	BKGG-0615	BKGG-0620

(2) Other Optional Parts

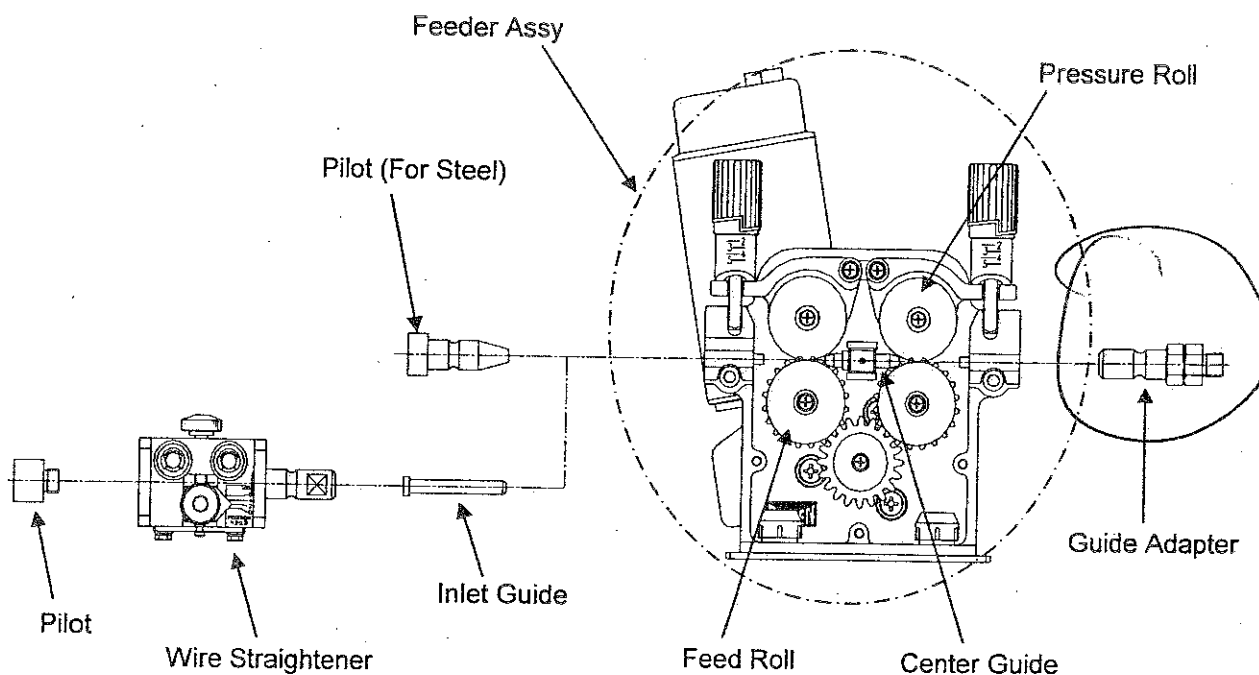

1. Roll (Select by welding process)

Wire Material	Wire Diameter	Feed Roll	Q'ty	Pressure Roll	Q'ty
Mild Steel Stainless Steel	1.4 / 1.6	K5439B01	2	K5439C00	2
	1.2 / 1.4	K5439B04	2	K5439C00	2
	1.2 / 1.2	K5439B05	2	K5439C00	2
	1.4 / 1.4	K5439B06	2	K5439C00	2
	1.6 / 1.6	K5439B07	2	K5439C00	2
	0.6 / 0.8	K5439B09	2	K5439C00	2
	1.6 / 2.0	K5439B10	2	K5439C00	2
	1.2 / 1.6	K5439B11	2	K5439C00	2
	0.9-1.0 / 1.2	K5439B12	2	K5439C00	2
Aluminum	0.8 / 0.9-1.0	K5439B13	2	K5439C00	2
	1.0 / 1.2	K5463R02	2	K5463R02	2
	1.2 / 1.6	K5463R03	2	K5463R03	2
	1.6 / 2.0	K5463R04	2	K5463R04	2
	1.6 / 2.4	K5463R05	2	K5463R05	2

9. PARTS LIST (continued)

2. Accessories

Part No.	Description	Q'ty	Remarks
U5209B00	Feeder Assy	1	
U5209J01	Guide Adapter	1	For Steel
U5204J01		1	For Aluminum
U5185B05	Center Guide (1.0-1.6)	1	For Steel
U5209M01	Center Guide (2.0)	1	For Steel
U5204B02	Center Guide (0.8-1.0)	1	For Aluminum
U5204B03	Center Guide (1.0-1.6)	1	For Aluminum
U5204B04	Center Guide (2.0-2.4)	1	For Aluminum
U5185P00	Feed Gear	2	For Steel
		4	For Aluminum
U5185J06	Pilot	1	For Steel
U5204H00	Wire Straightener	1	
U5204M02	Inlet Guide(For Wire Straightener)	1	For Steel
U5204J07		1	For Aluminum
K970G72	Pilot (For Wire Straightener)	1	For Steel
U2344C08		1	For Aluminum
U5185J05	Wire Reel Cover	1	Vinyl Cover
U5191E00		1	Plastic Half Cover
K5439E00		1	Dusting Type
U5191F00	Reel Adapter	1	
K5439F00	Caster	1	
U5191G00	Hanging Bracket	1	

U5278J01

9. PARTS LIST (continued)

3. Water Kit Part No. K5516A00

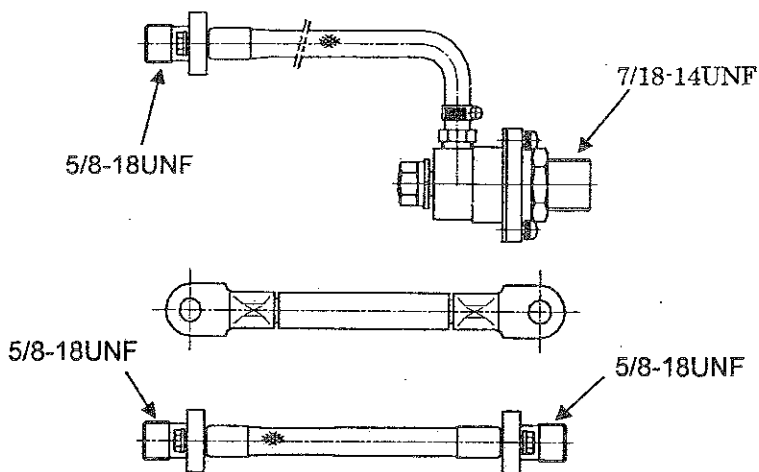

Part No.	Description	Q'ty	Remarks
U5204N00	Power Cable	1	
U5204P00	Power Connection	1	
U5204G00	Supply Water Hose	1	
U5204F00	Condensate Water Hose	1	

4. Aluminum Kit Part No. K5517A00

U5278J01

Part No.	Description	Q'ty	Remarks
U5204J04	Guide Adapter	1	
K5463R02	Feed Roll (1.0 / 1.2)	4	
U5204B03	Center Guide (1.0-1.6)	1	
U5185P00	Feed Gear	4	
U2344C08	Pilot (For Wire Straightener)	1	
U5204J07	Inlet Guide(For Wire Straightener)	1	For Aluminum
U5204H00	Wire Straightener	1	
U5191F00	Reel Adapter	1	
K5439E00	Wire Reel Cover	1	Dusting Type

AW-file

10. SPECIFICATIONS

10.1 Specifications

Model		CM-7401
Applicable wire size		(0.024" [0.6mm])* , (0.030" [0.8mm]), 0.035" [0.9mm], [1.0mm], 0.045" [1.2mm], (0.052" [1.4mm]), (1/16" [1.6mm])
Fire feeding rate		Max. 72.2 ft [22m] /min
Applicable wire reel.	Shaft diameter	1.97" [50mm] ϕ
	External diameter	Max. 11.8" [300mm] ϕ
	Wide	4.05" [103mm]
Quantity of applicable wire		Max. 55.1 lb [25kg]
Quantity		28.6 lb [13 kg]

*When using ϕ 0.6 wire, add the welding mode (optional) to the welding power source.

10.2 Available Welding Torch

Rated current	Duty cycle	Cable length			
		For mild steel			For aluminum
		10ft [3m]	13ft [4m]	15ft [4.5m]	13ft [4m]
200 A	40%				
200 A	70%		WTCMU-2001		WTCMU-2001
250 A	70%				WTCMUA-2501
350 A	30%	WTC-3504*			
350 A	70%	WTC-3503*		WTCMU-3503	
430 A	70%	WTC-4301*		WTCMU-4301	
500 A	70%	WTC-5002*		WTCMU-5002	

*For WTC-3503,3504,4301,5002 guide adapter (U5209J01) is needed.

10.3 Standard Accessory

Description	Part number	Quantity	Remarks
Pressure roll	K5439C00	(2)	Pre-installed
Feed roll (0.035" [0.9]-0.045" [1.0/1.2])	K5439B12	(2)	Pre-installed
Gas hose	K5430A00	1	BKGFF-0603 (10ft [3m])
Hose cover	U1997C03	2	Attached
Cable joint	4734-027	1	Attached

10. SPECIFICATIONS (continued)

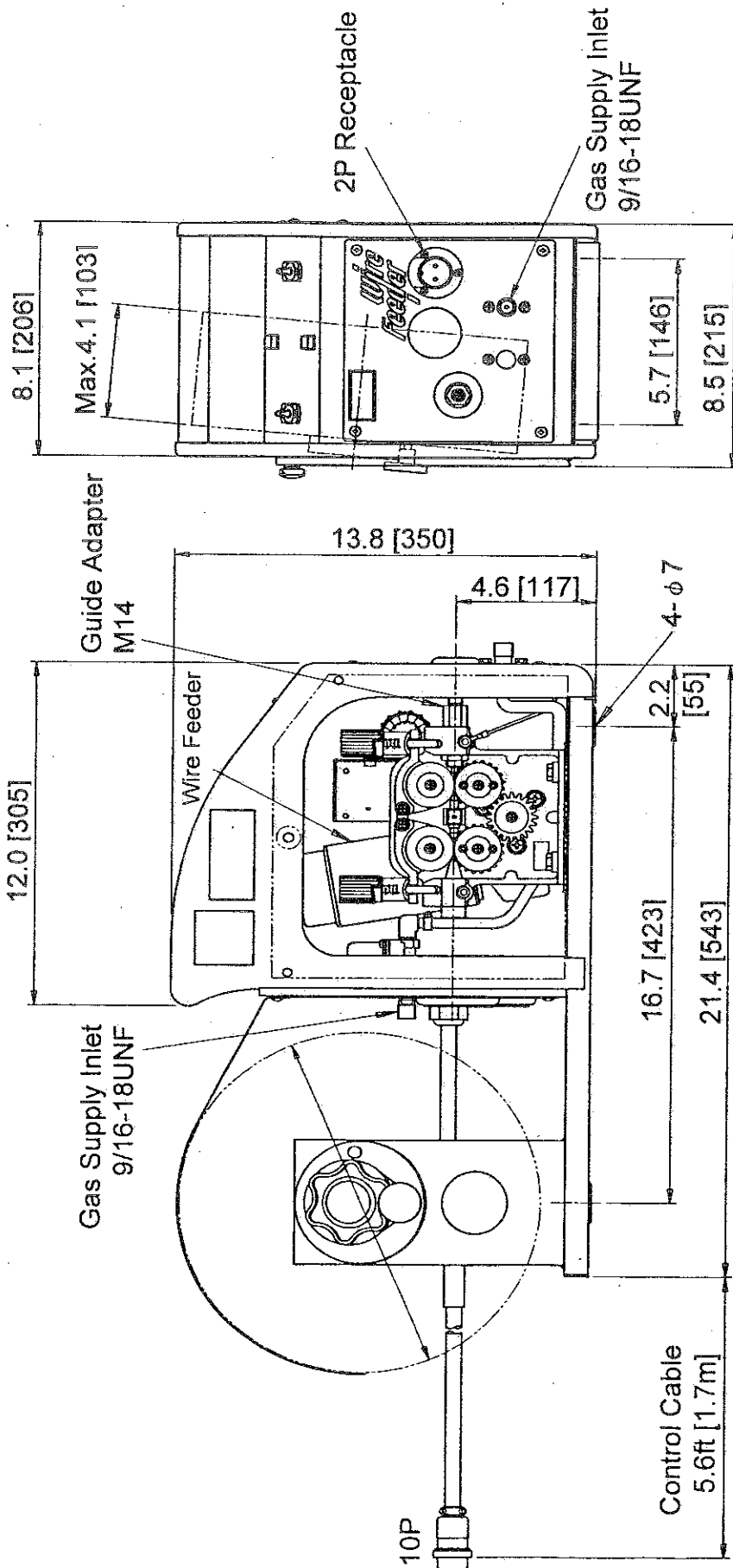

unit: in [mm]

External View of CM-7401 Wire Feeder



DAIHEN Corporation

5-1, Minamisenrioka, Settsu-shi, Osaka 566-0021, Japan

Phone: +81-6-6317-2506, Fax: +81-6-6317-2583

DAIHEN, INC.

DAYTON OFFICE

1400 Blausser Drive

Tipp City, Ohio 45371, USA

Phone: +1-937-667-0800, Fax: +1-937-667-0885

OTC DAIHEN EUROPE GmbH.

Krefelder Str. 677, D-41066 Mönchengladbach, F.R. GERMANY

Phone: +49-2161-69-49710, Fax: +49-2161-69-49711

OTC Industrial (Shanghai) Co.,Ltd.

7G Majesty Building, 138 Pu Dong Da Dao Shanghai

The People's Republic of China

Post Code: 200120

Phone: +86-21-58828633, Fax: +86-21-58828846

OTC (Taiwan) Co.,Ltd.

No. 63-4, Nan Yuan 2 Rd., Chung Li,

Taoyuan Hsien, Taiwan R.O.C.

Phone: +886-3-461-3962, Fax: +886-3-434-2394

OTC DAIHEN Asia Co.,Ltd.

60 / 86 Moo 19, Navanakorn Industrial Estate Phase 3,

Klong Nueng, Klong Luang, Pathumthani 12120

Phone: +66-2-909-4163, Fax: +66-2-909-4166

Upon contact, advise MODEL and MANUAL NO.