



Liquid Cooled MIG Welding Torch

BLUE TORCH

OWNER'S MANUAL Parts List

B T A W 4 0 0 - 4 0 U T 1 U 6 4 9 0

B T A W 4 0 0 - 4 0 U T

Rated Specification

Rated Current and Duty Cycle	400A 100%(MIG)/60%(PULSE MIG)
Torch Length	4.0m/ 15ft
Net Weight	
Diameter range of the electrode (mm) 1	1.2 , (1.6)
Diameter range of the electrode (inch) 1	.045 , (1/16)
Type of the electrode	Aluminium
Type of shielding gas	Ar
Type of cooling	Liquid Cooled
Minimum flow rate	0.7L/min
Minimum and maximum inlet pressure	0.10-0.35MPa
Minimum cooling power	
Method of guidance	Manual
Voltage rating	113V(Peak)
Torch switch technical data	DC30V 3A

1: "()": Optional parts are necessary.

Standard Parts List

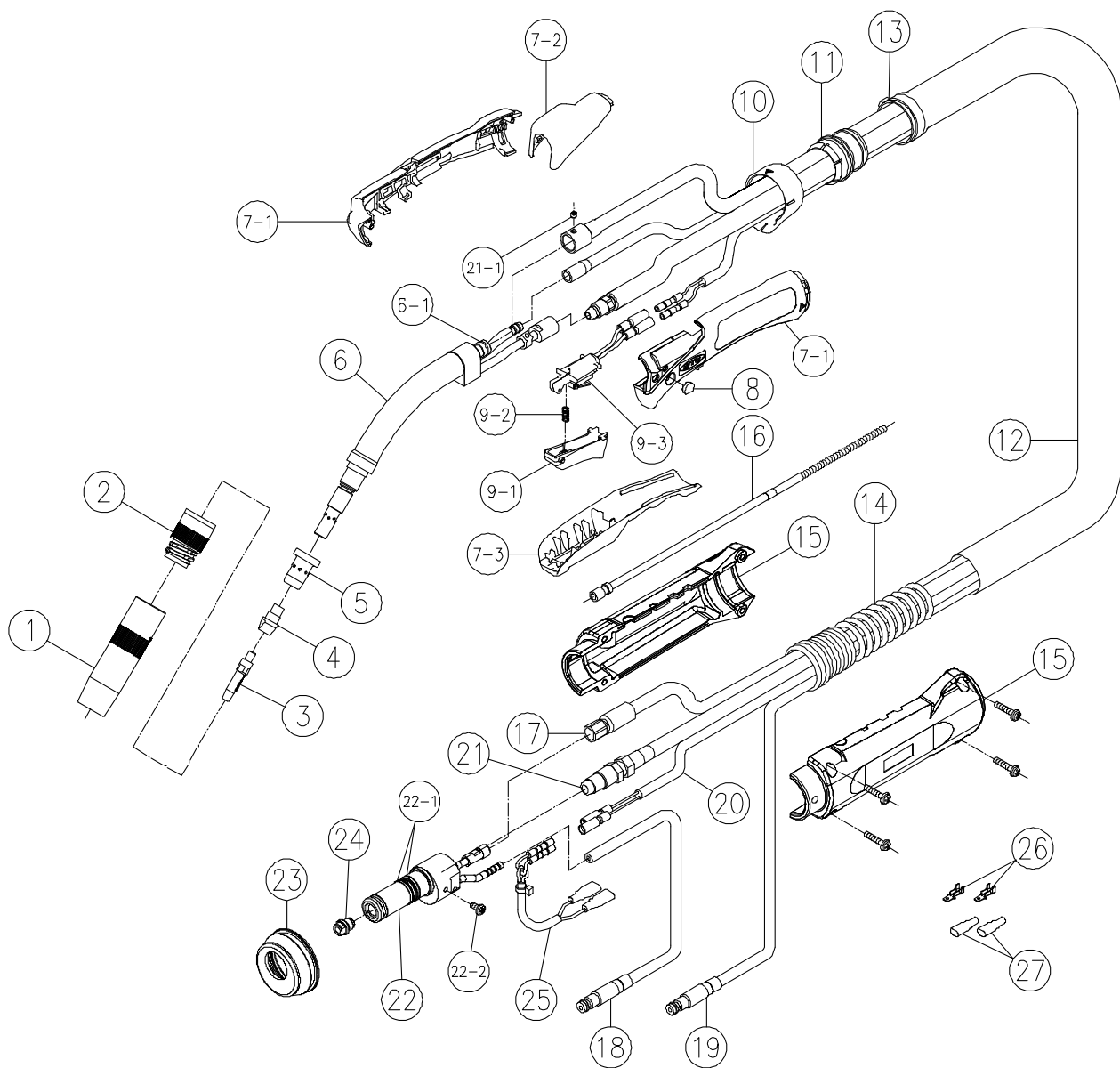

No.	Description	Part No.	No.	Description	Part No.
	Nozzle (I.D.17mm)	U5377G01		Binder	4739-606
	Insulator	U5626X00		Spring	U5626M04
	Contact Tip (1.2mm/.045")	K980B20		Cable Support (with Screw)	U6205S00
	Tip Nut	U5626M01		MIG Liner (1.0~1.2mm/.040"~.045")	U6490L00
	Orifice	U4173G02		Power Cable	U6490D00
	Torch Body (R100,45°)	U6315B00		Water Out Hose	U5626F00
-1	O-Ring(S9-4D)	3574-001		Water In Hose	U6490G00
	Handle KIT (-1 ~ 3 is included.)	U6256V00		Switch Cord	U6206G00
-1	Handle (L/R)	U6256D00	⑳	Conduit	U6206J00
-2	Handle (Upper)	U6196H03	㉑-1	Socket Screw(M4X4)	100-1715
-3	Handle (Lower)	U6196H04	㉒	Power Fitting "NO.5"	U5986L00
	Cap	U5341G01	㉒-1	O-Ring (JASO-1016(4D))	100-0819
	Trigger ASSY(-1 ~ 3 is included.)	U6205T00	㉒-2	Small Screw(M4X8)	100-0297
-1	Trigger	U6190T01	㉓	Rubber Sleeve	U5972G01
-2	Trigger Spring	U157E04	㉔	Wire Guide (1.2mm/.045")	U5984G02
-3	Switch ASSY	U6205Q00	㉕	Switch Cord	U6332F00
	Lock Ring	U6205H05	㉖	Terminal (LOM-21T-187)	100-0820
	End Joint	U5626R01	㉗	Cap (253224)	100-0821
	Hose Sheath	U6206R00	㉘	MIG Liner (1.6mm)	U6490Q00

Optional Parts List

UNIT (mm)

Contact Tip		MIG-Tip (M8)		Tip Nut	Wire Guide	
Wire Size	MIG-Tip (Standard)	MIG-Tip (M8)	MIG-Tip (M8)	For "MIG-Tip (M8)"	Wire Size	Part No.
1. 2mm (.045")	K980 B20	K980D42	U5626Z01	1.6mm (1/16")	U6000G02	
1. 6mm (1/16")	K980 B21	K980D43				

The dimension of the drawing is a reference value.

Modular Torch Handle/Trigger Options (tool-less/quick-change style)			
Extended Trigger	Slim Grip Handle	Trigger Guard Grip Handle	Pistol Grip Handle Kit
U6256T00 	U6256B01 	U6256B02 	U6256K00

- "Extended Trigger" is not made in combination with "Trigger Guard Grip Handle" and "Pistol Grip Handle Kit".
- "Switch ASSY(U6205Q00)" and "Trigger Spring(U157E04)" are not included in "Extended Trigger".
- "Trigger ASSY(U6205T00)" is not included in "Slim Grip Handle" and "Trigger Guard Grip Handle".
- Please order "U6256L00" towards "Trigger ASSY(U6205T00)" is not required to "Pistol Grip Handle Kit".

Heat Shield	
Standard	For "Pistol Grip Handle"
U6256H00 	U6256N00

Setting in points of the liner

Stretch the torch cable and confirm that there is no twist.

Insert the liner in the torch.

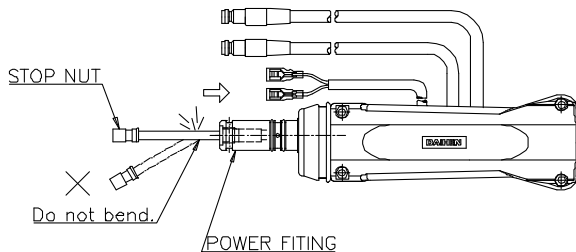

Fix the stop nut with the wire guide.

Cut the liner in the place where the liner went out from the torch body tip by 5-7mm.

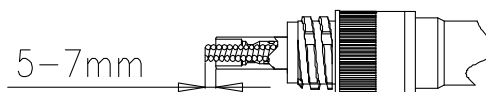
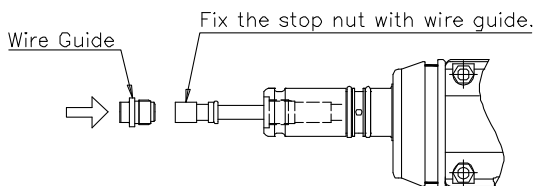

Torch Type

B T A W 4 0 0 - 4 0 U T

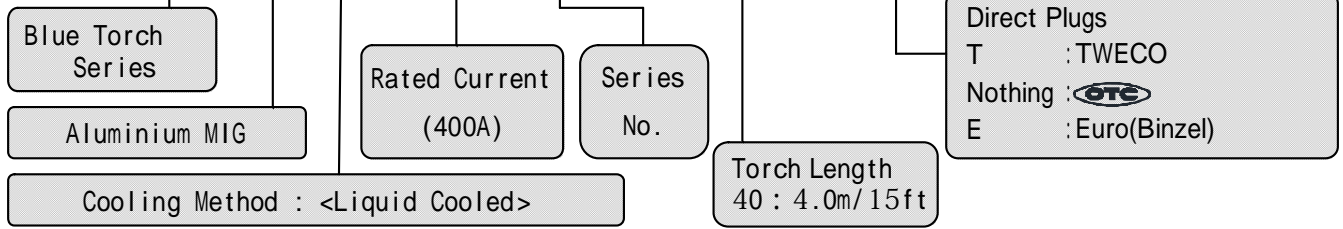

Dimensional Outline Drawing

UNIT(mm)

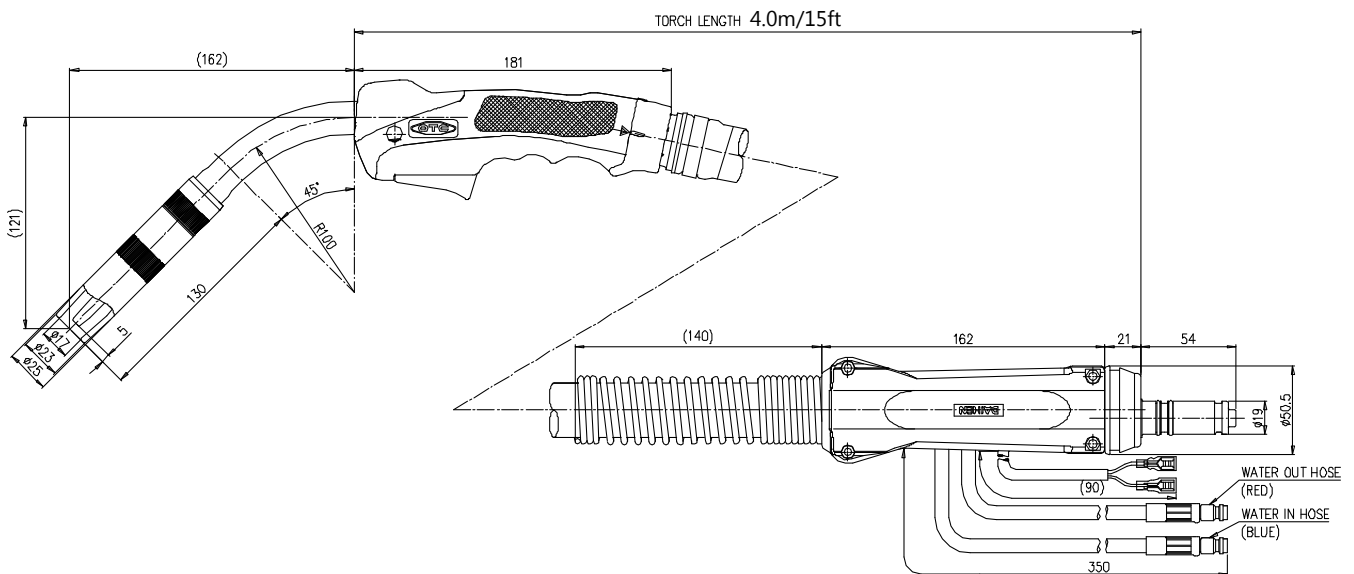

The dimension of the drawing is a reference value.



DAIHEN Corporation
4-1, Koyocho-nishi,
Higashinada-ku, Kobe,
Hyogo 658-0033, Japan
Phone: +81-78-275-2006,
Fax: +81-78-845-8159

DAIHEN Inc.
1400 Blauser Drive Tipp City,
Ohio 45371, USA
Phone: +1-937-667-0800,
Fax: +1-937-667-0885

OTC DAIHEN EUROPE GmbH
Krefelder Strasse 677,
D-41066 Mönchengladbach,
Germany
Phone: +49-2161-6949710,
Fax: +49-2161-6949711

OTC Industrial (Shanghai) Co.,Ltd.
6F, Building B,ORIENTO Plaza,
388 North Fuquan Road, Changning
District,Shanghai, China 200335
Phone: +86-21-5882-8633,
Fax: +86-21-5882-8846

OTC (Taiwan) Co.,Ltd.
2F No.153, Huanbei Rd.,
Chung Li City, Taoyuan
Hsien, Taiwan
Phone: +886-3-461-3962,
Fax: +886-3-434-2394

OTC DAIHEN INDIA Pvt.Ltd.
V.M.TOWER, Plot No.54A,
Ground Floor Unit-1, Sector-18,
Gurgaon-122015 Haryana, India
Phone:+91 124-4239368,
Fax:+91 124-4300820

DAIHEN Korea Co., Ltd.
11B/L Hyeongok Industrial
Complex, 463-1 Hyeongok-ri,
Cheongbuk-myeon, Pyeongtaek,
Gyeonggi-do, 451-831,
Republic of Korea
Phone: +82-31-686-7445,
Fax: +82-31-688-3464

OTC DAIHEN Asia Co.,Ltd.
23/43, 16th F1.Sorachai Building,
23 Soi 63 Sukhumvit Road,
Klongtonnua, Wattana, Bangkok
10110, Thailand
Phone: +66-2-714-3201,
Fax: +66-2-714-3204

PT.OTC DAIHEN INDONESIA
Blok G1A-20, Jl. Kenari II,
Delta Silicon V,
Lippo Cikarang Industrial
Park, Bekasi 17550 Indonesia
Phone:+6221-2957-7566,
Fax:+6221-2957-7567