

Liquid Cooled MIG Welding Torch

BLUE TORCH

OWNER'S MANUAL 『Parts List』

B T A W 4 0 0 - 3 0 U T . . . 1 U 6 3 3 2

B T A W 4 0 0 - 3 0 U T

Rated Specification

Rated Current and Duty Cycle	400A 100%(MIG)/60%(PULSE MIG)
Torch Length	3.0m / 10ft
Net Weight	2.7kg/6.0lb
Diameter range of the electrode (mm) 1	1.2 , (1.6)
Diameter range of the electrode (inch) 1	.045 , (1/16)
Type of the electrode	Aluminium
Type of shielding gas	Ar
Type of cooling	Liquid Cooled
Minimum flow rate	0.7L/min
Minimum and maximum inlet pressure	0.10-0.35MPa
Minimum cooling power	1.4kW
Method of guidance	Manual
Voltage rating	113V(Peak)
Torch switch technical data	DC30V 3A

1: "()": Optional parts are necessary.

Standard Parts List

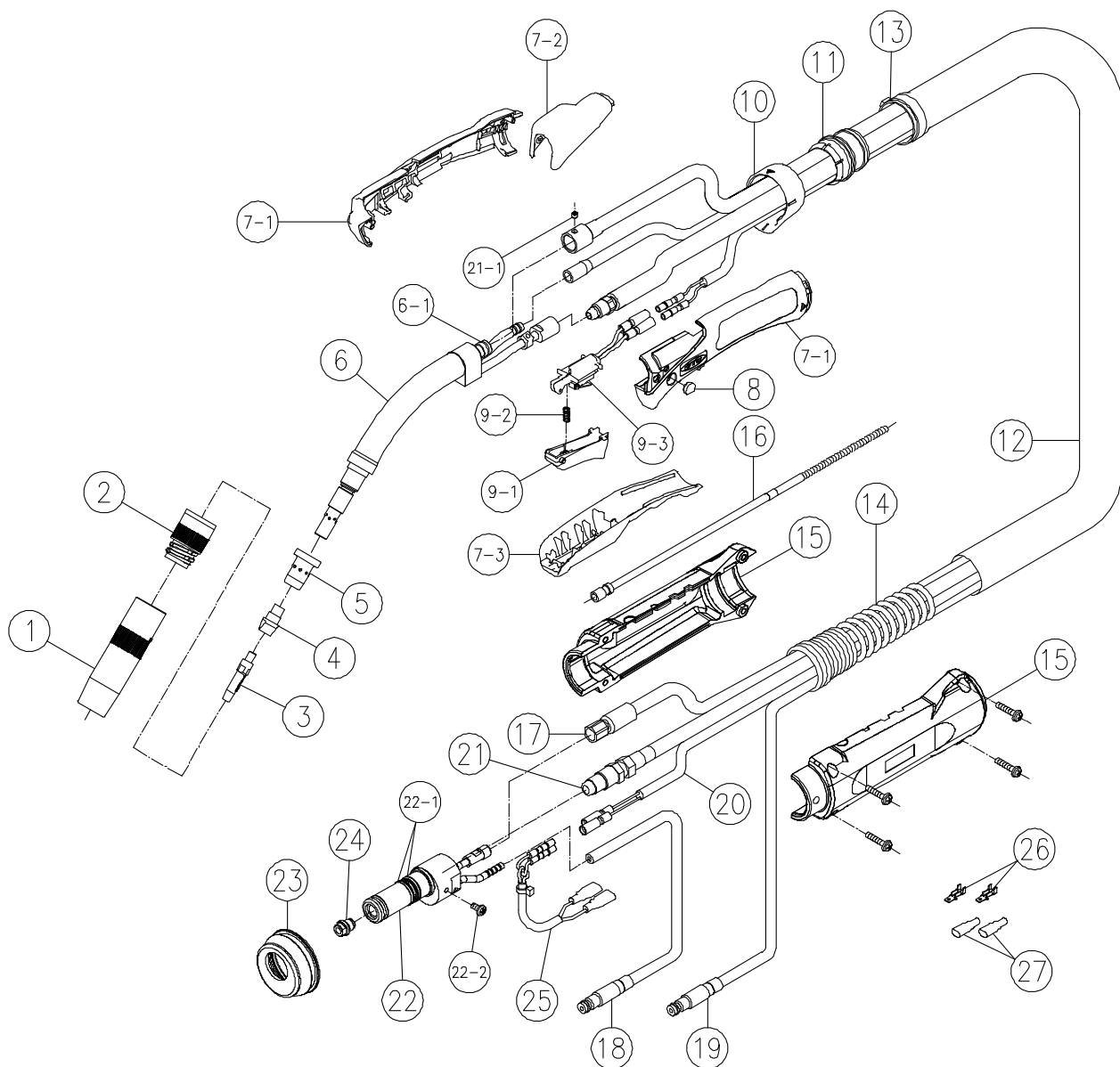

No.	Description	Part No.	No.	Description	Part No.
	Nozzle (I.D.17mm)	U5377G01		Binder	4739-606
	Insulator	U5626X00		Spring	U5626M04
	Contact Tip (1.2mm/.045")	K980B20		Cable Support (with Screw)	U6205S00
	Tip Nut	U5626M01		MIG Liner (1.0 ~ 1.2mm/.040" ~ .045")	U6315L00
	Orifice	U4173G02		Power Cable	U5626D00
	Torch Body (R100,45°)	U6315B00		Water Out Hose	U5626F00
-1	O-Ring(S9-4D)	3574-001		Water In Hose	U5626G00
	Handle KIT (-1 ~ 3 is included.)	U6256V00		Switch Cord	U6205G00
-1	Handle (L/R)	U6256D00	②①	Conduit	U6205J00
-2	Handle (Upper)	U6196H03	②①-1	Socket Screw(M4X4)	100-1715
-3	Handle (Lower)	U6196H04	②②	Power Fitting "NO.5"	U5986L00
	Cap	U5341G01	②②-1	O-Ring (JASO-1016(4D))	100-0819
	Trigger ASSY(-1 ~ 3 is included.)	U6205T00	②②-2	Small Screw(M4X8)	100-0297
-1	Trigger	U6190T01	②③	Rubber Sleeve	U5972G01
-2	Trigger Spring	U157E04	②④	Wire Guide (1.2mm/.045")	U5984G02
-3	Switch ASSY	U6205Q00	②⑤	Switch Cord	U6332F00
	Lock Ring	U6205H05	②⑥	Terminal (LOM-21T-187)	100-0820
	End Joint	U5626R01	②⑦	Cap (253224)	100-0821
	Hose Sheath	U6205R00			

Optional Parts List

UNIT (mm)

Contact Tip		MIG Liner			Wire Guide	
	MIG-Tip (Standard)	Wire Size	Length	Part No.	Wire Size	Part No.
Wire Size		1.0mm ~ 1.2mm (.040" ~ .045")	3.0m/10ft	U6315L00	1.6mm (1/16")	U6000G02
		1.6mm (1/16")	3.0m/10ft	U6315Q00		
1.2mm (.045")	K 980 B20					
1.6mm (1/16")	K 980 B21					

The dimension of the drawing is a reference value.

Modular Torch Handle/Trigger Options (tool-less/quick-change style)			
Extended Trigger	Slim Grip Handle	Trigger Guard Grip Handle	Pistol Grip Handle Kit
U6256T00	U6256B01	U6256B02	U6256K00 Assembly

- "Extended Trigger" is not made in combination with "Trigger Guard Grip Handle" and "Pistol Grip Handle Kit".
- "Switch ASSY(U6205Q00)" and "Trigger Spring(U157E04)" are not included in "Extended Trigger".
- "Trigger ASSY(U6205T00)" is not included in "Slim Grip Handle" and "Trigger Guard Grip Handle".
- Please order "U6256L00" towards "Trigger ASSY(U6205T00)" is not required to "Pistol Grip Handle Kit".

Heat Shield	
Standard	For "Pistol Grip Handle"
U6256H00	U6256N00

Setting in points of the liner

Stretch the torch cable and confirm that there is no twist.

Insert the liner in the torch.

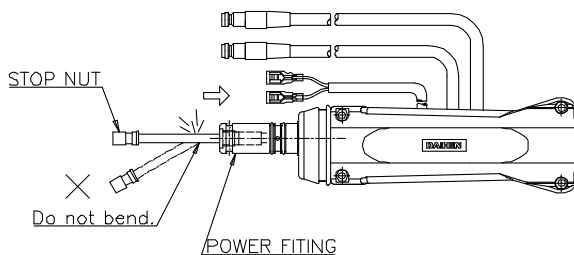

Fix the stop nut with the wire guide.

Cut the liner in the place where the liner went out from the torch body tip by 5-7mm.

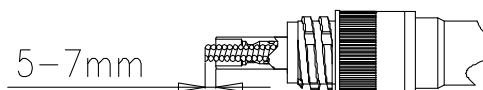
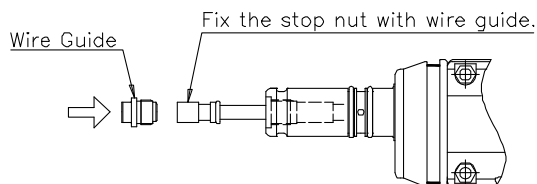

Torch Type

B T A W 4 0 0 - 3 0 U T

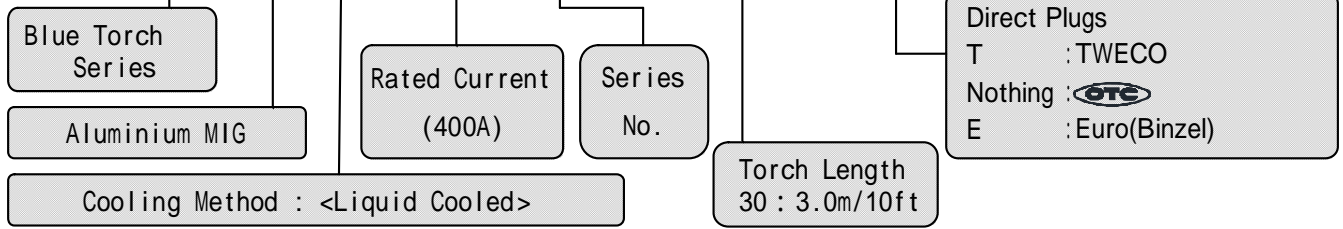

Dimensional Outline Drawing

UNIT(mm)

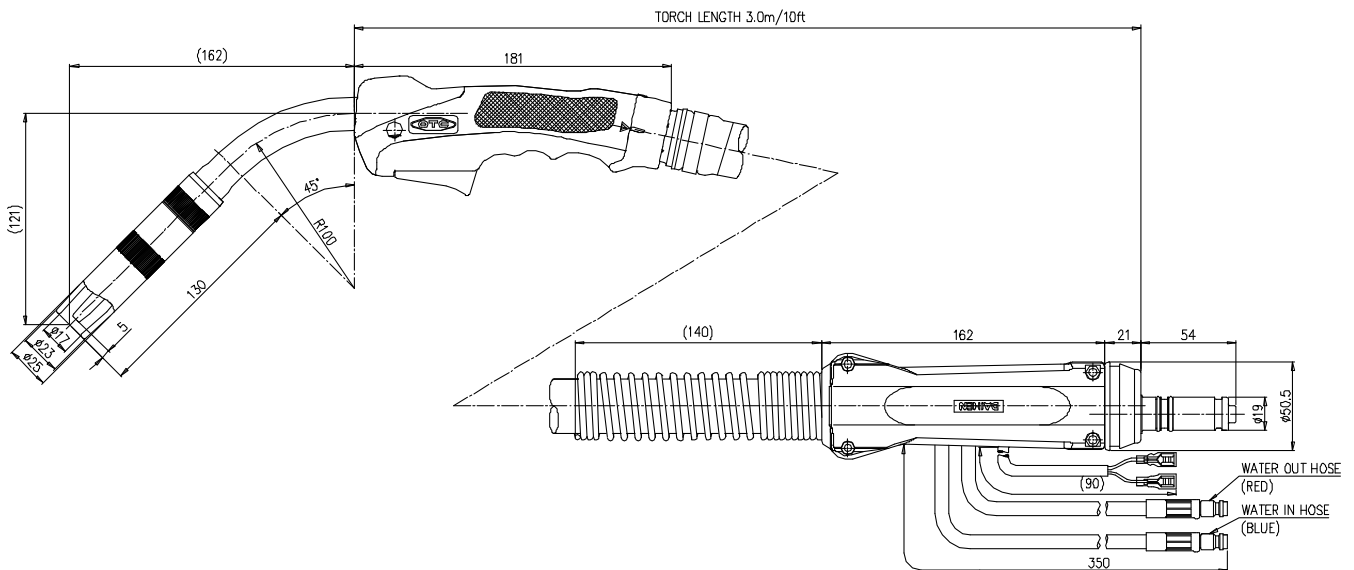

The dimension of the drawing is a reference value.



DAIHEN Corporation
4-1, Koyocho-nishi,
Higashinada-ku, Kobe,
Hyogo 658-0033, Japan
Phone: +81-78-275-2006,
Fax: +81-78-845-8159

DAIHEN Inc.
1400 Blauser Drive Tipp City,
Ohio 45371, USA
Phone: +1-937-667-0800,
Fax: +1-937-667-0885

OTC DAIHEN EUROPE GmbH
Krefelder Strasse 677,
D-41066 Mönchengladbach,
Germany
Phone: +49-2161-6949710,
Fax: +49-2161-6949711

OTC Industrial (Shanghai) Co.,Ltd.
6F, Building B,ORIENTO Plaza,
388 North Fuquan Road, Changning
District,Shanghai, China 200335
Phone: +86-21-5882-8633,
Fax: +86-21-5882-8846

OTC (Taiwan) Co.,Ltd.
2F No.153, Huanbei Rd.,
Chung Li City, Taoyuan
Hsien, Taiwan
Phone: +886-3-461-3962,
Fax: +886-3-434-2394

OTC DAIHEN INDIA Pvt.Ltd.
V.M.TOWER, Plot No.54A,
Ground Floor Unit-1, Sector-18,
Gurgaon-122015 Haryana, India
Phone:+91 124-4239368,
Fax:+91 124-4300820

DAIHEN Korea Co., Ltd.
11B/L Hyeongok Industrial
Complex, 463-1 Hyeongok-ri,
Cheongbuk-myeon, Pyeongtaek,
Gyeonggi-do, 451-831,
Republic of Korea
Phone: +82-31-686-7445,
Fax: +82-31-686-7464

OTC DAIHEN Asia Co.,Ltd.
23/43, 16th F1.Sorachai Building,
23 Soi 63 Sukhumvit Road,
Klongtonnua, Wattana, Bangkok
10110, Thailand
Phone: +66-2-714-3201,
Fax: +66-2-714-3204

PT.OTC DAIHEN INDONESIA
Blok G1A-20, Jl. Kenari II,
Delta Silicon V,
Lippo Cikarang Industrial
Park, Bekasi 17550 Indonesia
Phone:+6221-2957-7566,
Fax:+6221-2957-7567