



*Air Cooled CO2/MAG Welding Torch*

# ***BLUE TORCH III***

## **OWNER'S MANUAL** 『Parts List』

BT5000-30UT . . . 1U6324  
BT5000-45UT . . . 1U6325  
BT5000-60UT . . . 1U6326

# ***BT5000-30UT*** ***BT5000-45UT*** ***BT5000-60UT***

### ■ Rated Specification

Rated Current and Duty Cycle		500A 60%(CO2) / 450A 30%(MAG)		
Torch Length		3.0m/10ft	4.5m/15ft	6.0m/20ft
Net Weight		3.6kg/7.9lb	4.8kg/10.6lb	5.9kg/13.0lb
Diameter range of the electrode ※1	mm	1.2 , (1.4) , (1.6)		
	inch	.045 , (.052) , (1/16)		
Type of the electrode		Mild steel wire , Flux-cored wire		
Type of shielding gas		CO2 , MAG		
Type of cooling		Air Cooled		
Method of guidance		Manual		
Voltage rating		113V(Peak)		
Torch switch technical data		DC30V 3A		

※1:“( )”: Optional parts are necessary.

## Standard Parts List

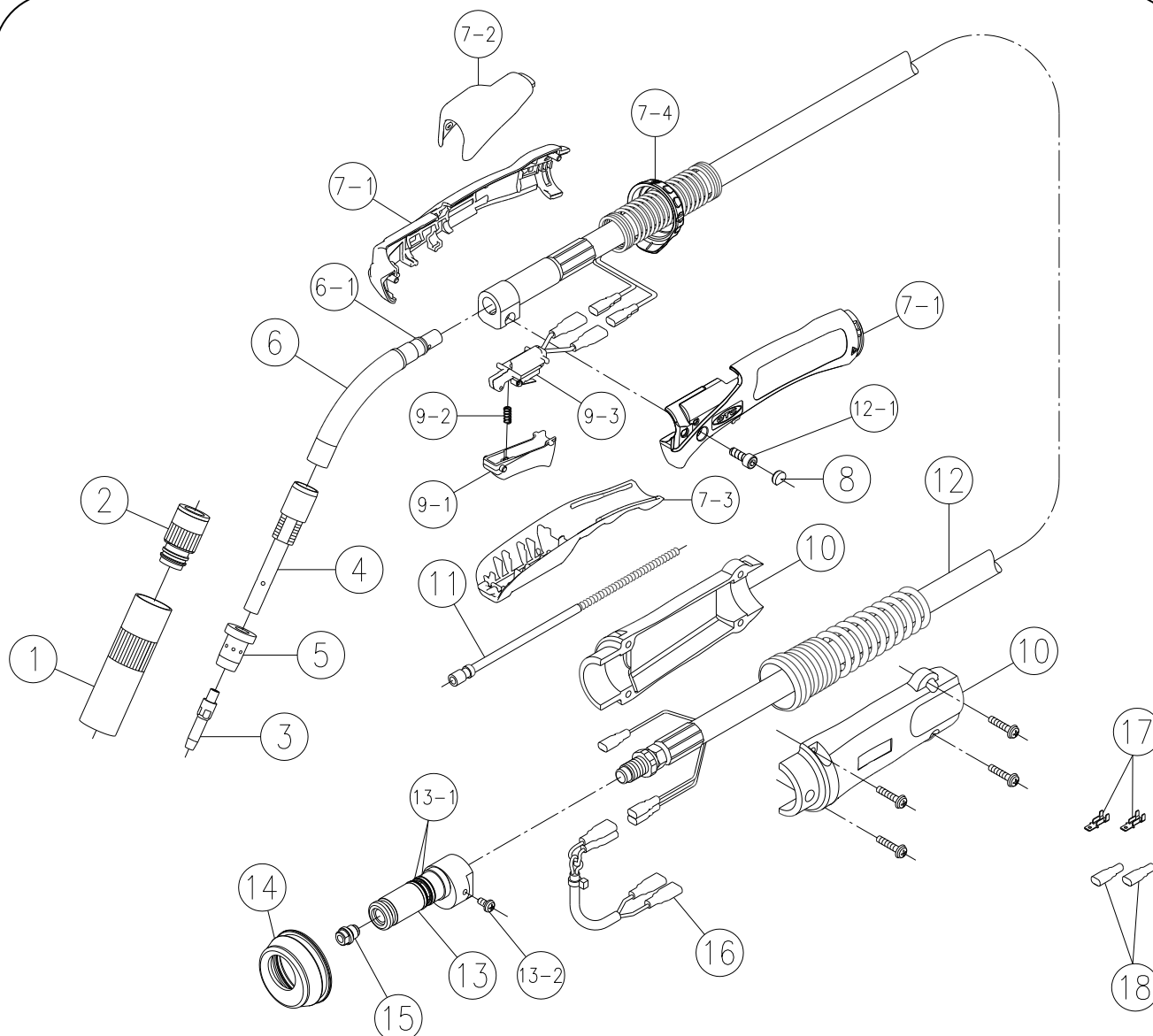



No.	Part Description	Part No.	No.	Part Description	Part No.
①	Nozzle (I.D.19mm)	U4173G01	⑩	Cable Support (with Screw)	U6190S00
②	Insulator	U4173L00	⑪	Liner	
③	Contact Tip (1.2mm/.045")	K980C26		3.0m/10ft (1.2~1.6mm/.045"~1/16")	U6199L00
④	Tip Body	U4173G21		4.5m/15ft (1.2~1.6mm/.045"~1/16")	U6200L00
⑤	Orifice	U4173G02		6.0m/20ft (1.2~1.6mm/.045"~1/16")	U6201L00
⑥	Torch Body (R130,55° )	U6202B00	⑫	Power Cable (Screw, Reinforcing Spring is included.)	
⑥-1	O-Ring (S9-4D)	3574-001		3.0m/10ft	U6202D00
⑦	Handle KIT (⑦-1~4 is included.)	U6256C00		4.5m/15ft	U6203D00
⑦-1	Handle (L/R)	U6256D00		6.0m/20ft	U6204D00
⑦-2	Handle (Upper)	U6196H03	⑫-1	Bolt with hole (M5X14)	100-0310
⑦-3	Handle (Lower)	U6196H04	⑬	Power Fitting "NO.5" (with Screw)	U5981E00
⑦-4	LockRing	U6196H05	⑬-1	O-Ring (JASO-1016(4D))	100-0819
⑧	Cap	U5341G01	⑬-2	Small Screw (M4X8)	100-0297
⑨	Trigger ASSY (⑨-1~3 is included.)	U6190T00	⑭	Rubber Sleeve	U5972G01
⑨-1	Trigger	U6190T01	⑮	Wire Guide (1.2~1.6mm/.045"~1/16")	U5978G02
⑨-2	Trigger Spring	U157E04	⑯	Switch Cord	U5972F00
⑨-3	Switch ASSY	U6190Q00	⑰	Terminal (LOM-21T-187)	100-0820
			⑱	Cap (253224)	100-0821

# Optional Parts List

※The dimension of the drawing is a reference value.

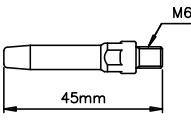
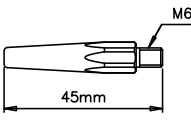
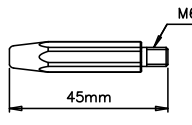
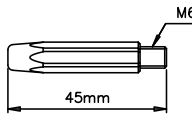
UNIT (mm)

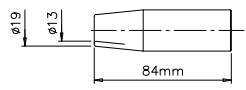
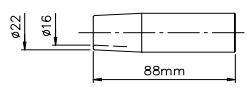
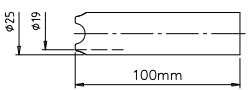
Contact Tip				
	A-Tip (Standard)	T-Tip (High Current)	CW-Tip (Long Life)	Heavy Current
Wire Size				
1. 2mm (.045")	K980C26 K980C73 (For FCW)	K980C19	K990E12	U4167H12
1. 4mm (.052")	K980C27 K980C74 (For FCW)	K980C20	K990E14	U4167H11
1. 6mm (1/16")	K980C28	K980C21	K990E16	U4167H10

Nozzle			Heat Shield	
Low Current		Arc Spot	Standard	For "Pistol Grip Handle"
U5353V01	U4173H01	U4173H02	U6256H00	U6256N00
				

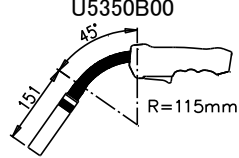
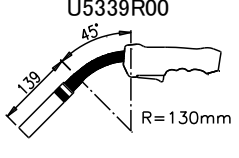
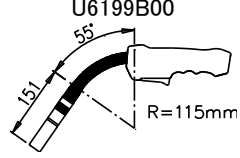
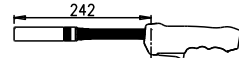
Torch Body			
R115, 45°	R130, 45°	R115, 55°	Straight
U5350B00	U5339R00	U6199B00	U5339J00
			

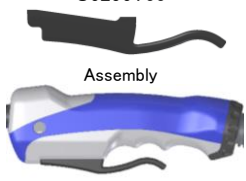
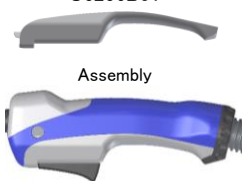
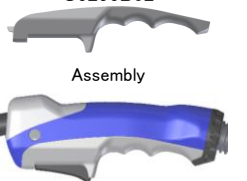
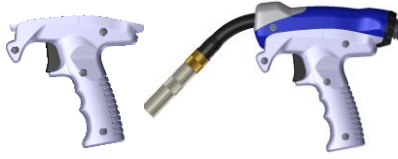
Modular Torch Handle/Trigger Options				(tool-less/quick-change style)
Extended Trigger	Slim Grip Handle	Trigger Guard Grip Handle	Pistol Grip Handle Kit	
U6256T00	U6256B01	U6256B02	U6256K00	Assembly
				

※1 "Extended Trigger" is not made in combination with "Trigger Guard Grip Handle" and "Pistol Grip Handle Kit".  
 ※2 "Switch ASSY(U6190Q00)" and "Trigger Spring(U157E04)" are not included in "Extended Trigger".  
 ※3 "Trigger ASSY(U6190T00)" is not included in "Slim Grip Handle" and "Trigger Guard Grip Handle".  
 ※4 Please order "U6256M00" towards "Trigger ASSY(U6190T00)" is not required to "Pistol Grip Handle Kit".

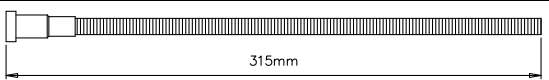
Inner Liner		
Wire Size	Part No.	These are available for the torch bodies above.
1.2~1.6mm/.045"~1/16"	U5003L26	
		

Liner		
Wire Size	Length	Part No.
1.2mm/.045"	6.0m/20ft	U6195L00

■ Voltage Detecting Cable  
 Part No. : U 5 3 6 5 P 0 0

※In order to use voltage detecting cable, you will need to modify the welding power source and wire feeder.  
 For detail, see owner's manual of the welding power source and wire feeder.

## Torch Type

# BT 5000-3OUT

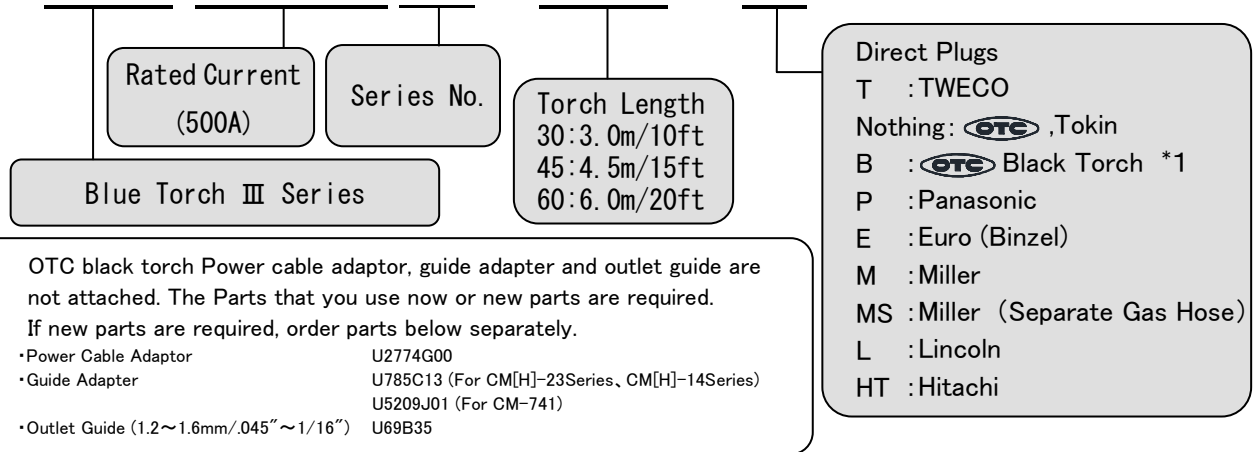

## Dimensional Outline Drawing

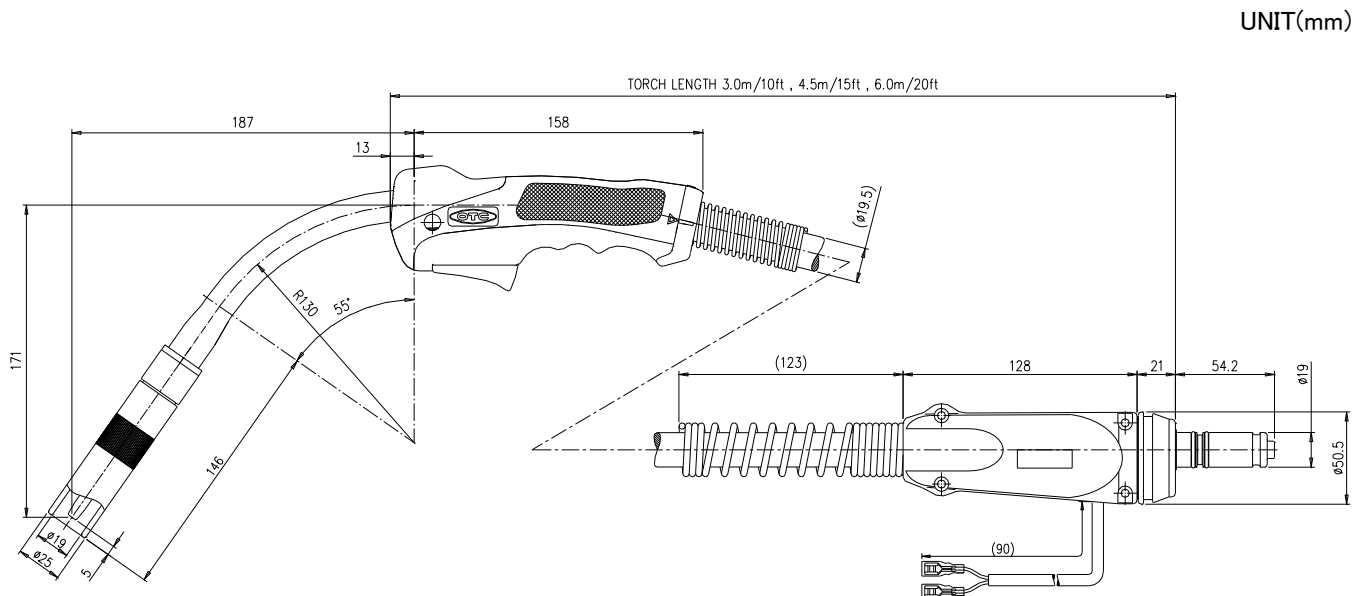

※The dimension of the drawing is a reference value.



**DAIHEN Corporation**  
 4-1, Koyochi-nishi,  
 Higashinada-ku, Kobe,  
 Hyogo 658-0033, Japan  
 Phone: +81-78-275-2006,  
 Fax: +81-78-845-8159

**DAIHEN Inc.**  
 1400 Blauser Drive Tipp City,  
 Ohio 45371, USA  
 Phone: +1-937-667-0800,  
 Fax: +1-937-667-0885

**OTC DAIHEN EUROPE GmbH**  
 Krefelder Strasse 677,  
 D-41066 Mönchengladbach,  
 Germany  
 Phone: +49-2161-6949710,  
 Fax: +49-2161-6949711

**OTC Industrial (Shanghai) Co.,Ltd.**  
 6F, Building B,ORIENTO Plaza,  
 388 North Fuquan Road, Changning  
 District,Shanghai, China 200335  
 Phone: +86-21-5882-8633,  
 Fax: +86-21-5882-8846

**OTC (Taiwan) Co.,Ltd.**  
 2F No.153, Huanbei Rd.,  
 Chung Li City, Taoyuan  
 Hsien, Taiwan  
 Phone: +886-3-461-3962,  
 Fax: +886-3-434-2394

**OTC DAIHEN INDIA Pvt.Ltd.**  
 V.M.TOWER, Plot No.54A,  
 Ground Floor Unit-1, Sector-18,  
 Gurgaon-122015 Haryana, India  
 Phone:+91 124-4239368,  
 Fax:+91 124-4300820

**DAIHEN Korea Co., Ltd.**  
 11B/L Hyeongok Industrial  
 Complex, 463-1 Hyeongok-ri,  
 Cheongbuk-myeon, Pyeongtaek,  
 Gyeonggi-do, 451-831,  
 Republic of Korea  
 Phone: +82-31-686-7445,  
 Fax: +82-31-686-7464

**OTC DAIHEN Asia Co.,Ltd.**  
 23/43, 16th F1.Sorachai Building,  
 23 Soi 63 Sukhumvit Road,  
 Klongtonnua, Wattana, Bangkok  
 10110, Thailand  
 Phone: +66-2-714-3201,  
 Fax: +66-2-714-3204

**PT.OTC DAIHEN INDONESIA**  
 Blok G1A-20, Jl. Kenari II,  
 Delta Silicon V,  
 Lippo Cikarang Industrial  
 Park, Bekasi 17550 Indonesia  
 Phone:+6221-2957-7566,  
 Fax:+6221-2957-7567