

*Air Cooled CO<sub>2</sub>/MAG Welding Torch*

# **BLUE TORCH III**

## **OWNER'S MANUAL** 『Parts List』

BT380D-30UT . . . 1U6337  
 BT380D-45UT . . . 1U6338  
 BT380D-60UT . . . 1U6339

# **BT380D-30UT**

# **BT380D-45UT**

# **BT380D-60UT**

■ Rated Specification

Rated Current and Duty Cycle		380A 35%(CO <sub>2</sub> ) / 340A 35%(MAG)		
Torch Length		3.0m/10ft	4.5m/15ft	6.0m/20ft
Net Weight		3.8kg/8.4lb	5.1kg/11.2lb	6.4kg/14.1lb
Diameter range of the electrode ※1	mm	1.2 , (1.4) , (1.6)		
	inch	.045 , (.052) , (1/16)		
Type of the electrode		Mild steel wire , Flux-cored wire		
Type of shielding gas		CO <sub>2</sub> , MAG		
Type of cooling		Air Cooled		
Method of guidance		Manual		
Voltage rating		113V(Peak)		
Torch switch technical data		DC30V 3A		

※1:“( )”: Optional parts are necessary.

## Standard Parts List

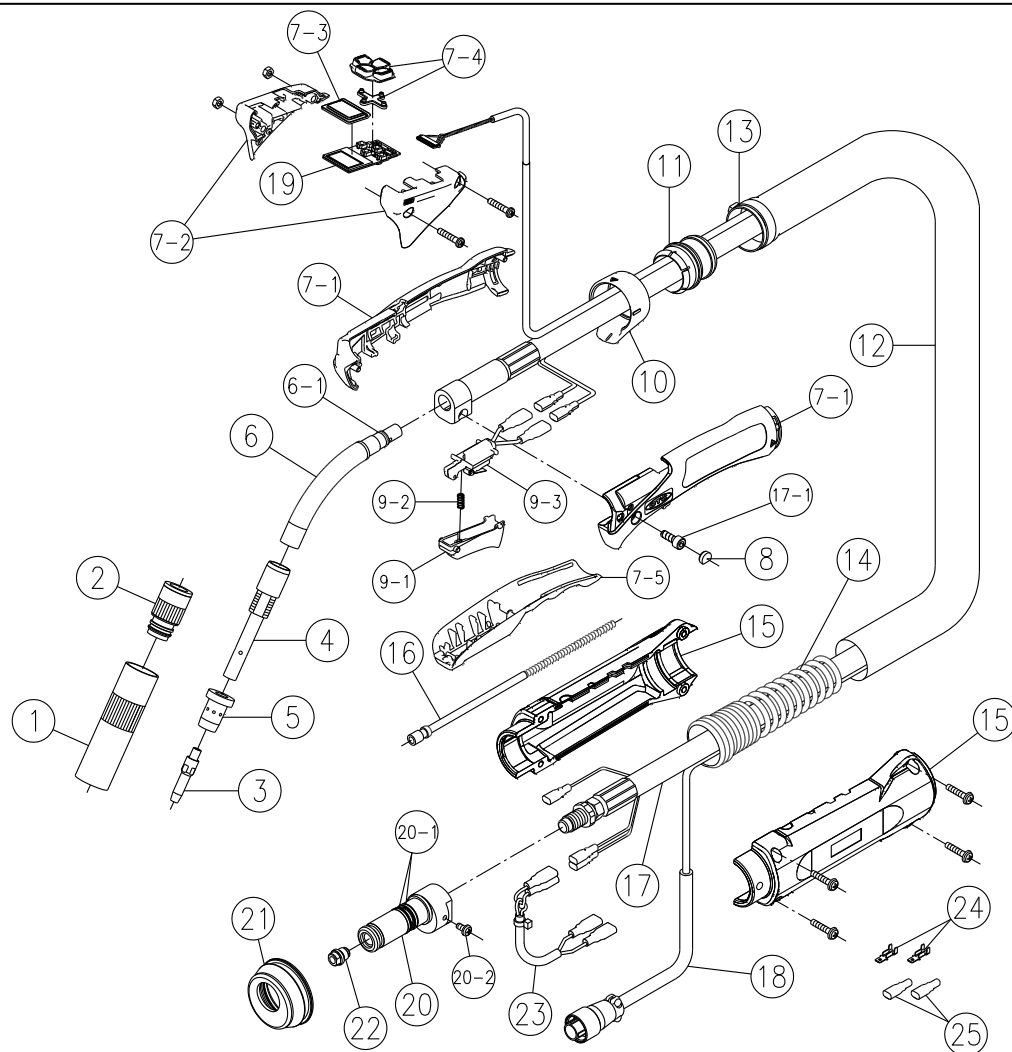



No.	Part Description	Part No.	No.	Part Description	Part No.
①	Nozzle (I.D.16mm)	U4167H16	⑬	Binder	4739-606
②	Insulator	U4167L00	⑭	Spring	U5626M04
③	Contact Tip (1.2mm/.045")	K980C26	⑮	Cable Support (with Screw)	U6205S00
④	Tip Body	U4167G03		Liner	
⑤	Orifice	U4167G02	⑯	3.0m/10ft (0.9~1.2mm/.035"~.045")	U4170H02
⑥	Torch Body (R115,55°)	U6199B00		4.5m/15ft (1.0~1.2mm/.040"~.045")	U6194L00
⑥-1	O-Ring (S9-4D)	3574-001		6.0m/20ft (1.2mm/.045")	U6195L00
⑦	Handle KIT (⑦-1~5 is included.)	U6280V00		Power Cable (with Screw)	
⑦-1	Handle (L/R)	U6256D00	⑰	3.0m/10ft	U6289D00
⑦-2	Handle (Upper L/R with Screw)	U6280X00		4.5m/15ft	U6290D00
⑦-3	Screen Cover	U6280H03		6.0m/20ft	U6291D00
⑦-4	Button (with Button Guide)	U6280Y00	⑰-1	Bolt with hole (M5X14)	100-0310
⑦-5	Handle (Lower)	U6196H04		Communication Cable	
⑧	Cap	U5341G01	⑱	3.0m/10ft	U6286U00
⑨	Trigger ASSY (⑨-1~3 is included.)	U6190T00		4.5m/15ft	U6287U00
⑨-1	Trigger	U6190T01		6.0m/20ft	U6288U00
⑨-2	Trigger Spring	U157E04	⑲	Control Board	K5961P00
⑨-3	Switch ASSY	U6190Q00	⑳	Power Fitting "NO.4" (with Screw)	U5972E00
⑩	Lock Ring	U6205H05	⑳-1	O-Ring (AS-014(4D))	100-0818
⑪	End Joint	U5626R01	⑳-2	Small Screw (M4X8)	100-0297
	Hose Sheath		㉑	Rubber Sleeve	U5972G01
⑫	3.0m/10ft	U6205R00	㉒	Wire Guide (0.9~1.2mm/.035"~.045")	U5972G02
	4.5m/15ft	U6287R00	㉓	Switch Cord	U5972F00
	6.0m/20ft	U6288R00	㉔	Terminal (LOM-21T-187)	100-0820
			㉕	Cap (253224)	100-0821

# Optional Parts List

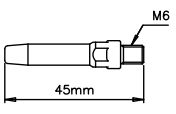
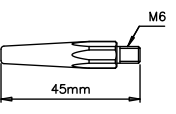
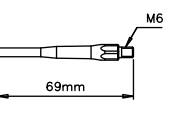
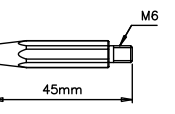
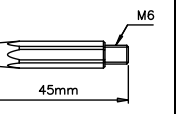

※The dimension of the drawing is a reference value.

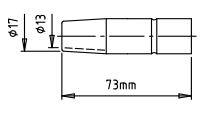
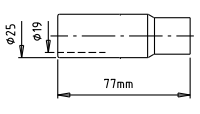
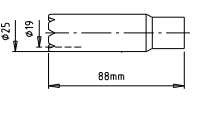
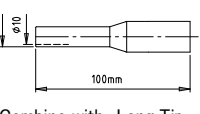
UNIT (mm)

Contact Tip					
	A-Tip (Standard)	T-Tip (High Current)	Long Tip	CW-Tip (Long Life)	Heavy Current
Wire Size					
1. 2mm (.045")	K980C26 K980C73 (For FCW)	K980C19	U4167H05	K990E12	U4167H12
1. 4mm (.052")	K980C27 K980C74 (For FCW)	K980C20	-	K990E14	U4167H11
1. 6mm (1/16")	K980C28	K980C21	-	K990E16	U4167H10

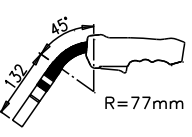
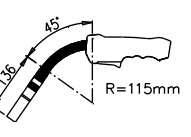
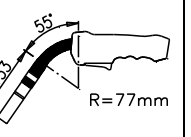
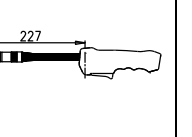
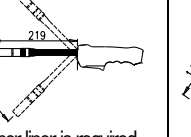
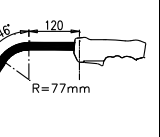
Nozzle				Heat Shield	
Low Current	High Current	Arc Spot	Deep and Narrow Space	Standard	For "Pistol Grip Handle"
U4167H01	U4167H02	U4167H03	U4167H04	U6256H00	U6256N00
					
			Combine with Long Tip.		

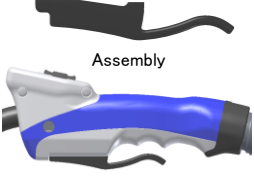
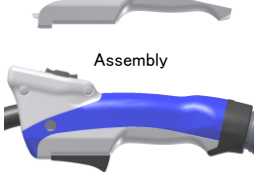
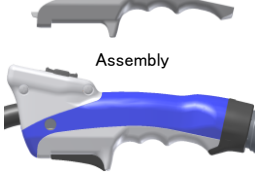
Torch Body					
R77, 45°	R115, 45°	R77, 55°	Straight	Flexible	Long Neck
U5347B00	U5350B00	U6196B00	U5339J00	U5339L00	U5339N00
					
				Inner liner is required.	

Modular Torch Handle/Trigger Options				(tool-less/quick-change style)
Extended Trigger	Slim Grip Handle	Trigger Guard Grip Handle	Pistol Grip Handle Kit	
U6256T00	U6256B01	U6256B02	U6256K00	Assembly
				
Assembly	Assembly	Assembly		

Wire Guide	
Wire Size	Part No.
1.2~1.6mm .045"~1/16"	U5978G02

※1 "Extended Trigger" is not made in combination with "Trigger Guard Grip Handle" and "Pistol Grip Handle Kit".  
 ※2 "Switch ASSY(U6190Q00)" and "Trigger Spring(U157E04)" are not included in "Extended Trigger".  
 ※3 "Trigger ASSY(U6190T00)" is not included in "Slim Grip Handle" and "Trigger Guard Grip Handle".  
 ※4 Please order "U6256M00" towards "Trigger ASSY(U6190T00)" is not required to "Pistol Grip Handle Kit".

Inner Liner		
Wire Size	Part No.	These are available for the torch bodies above.
1.2~1.6mm/.045"~1/16"	U5003L26	
		

Liner		
Wire Size	Length	Part No.
1.2~1.6mm/.045"~1/16"	3.0m/10ft	U6199L00
1.2~1.6mm/.045"~1/16"	4.5m/15ft	U6200L00
1.2~1.6mm/.045"~1/16"	6.0m/20ft	U6201L00

■ Voltage Detecting Cable  
 Part No. : U 5 3 6 5 P 0 0

※In order to use voltage detecting cable, you will need to modify the welding power source and wire feeder. For detail, see owner's manual of the welding power source and wire feeder.

■ Intelligent torch combined equipment

Wire Feeder : CM - 7 4 3 - U  
 + Intelligent panel kit (K5952G00)  
 + LCD panel (E-2627) or digital panel (E-2628)  
 Welding Power Source : CO2/MAG Welbee series

## Torch Type

# BT 380D-30UT

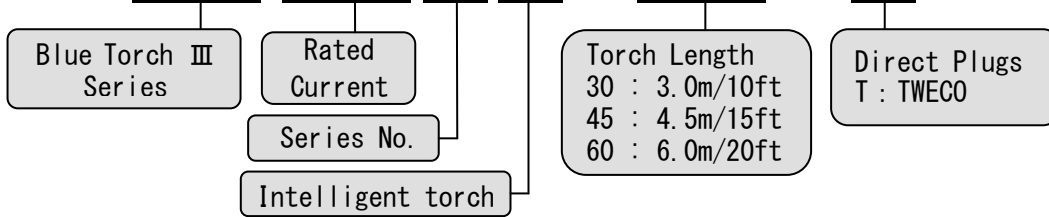

## Electrical connection diagram

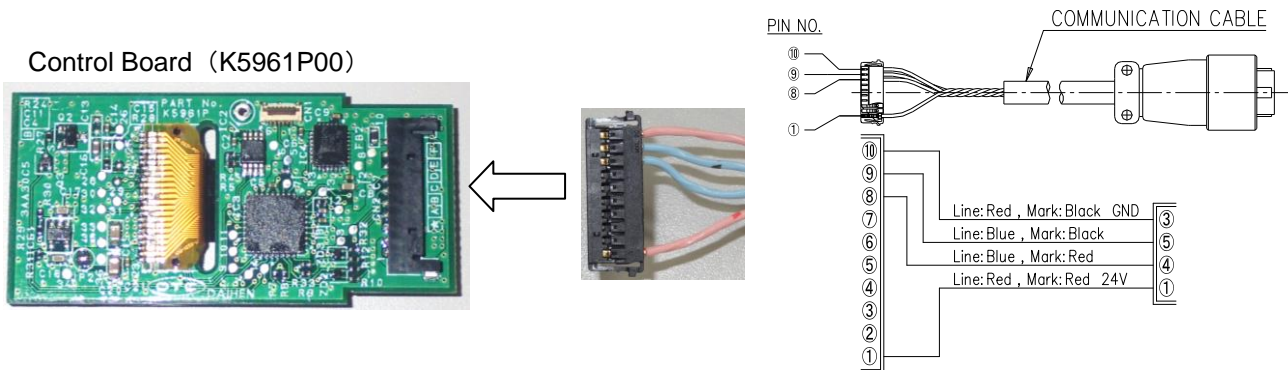

## Dimensional Outline Drawing

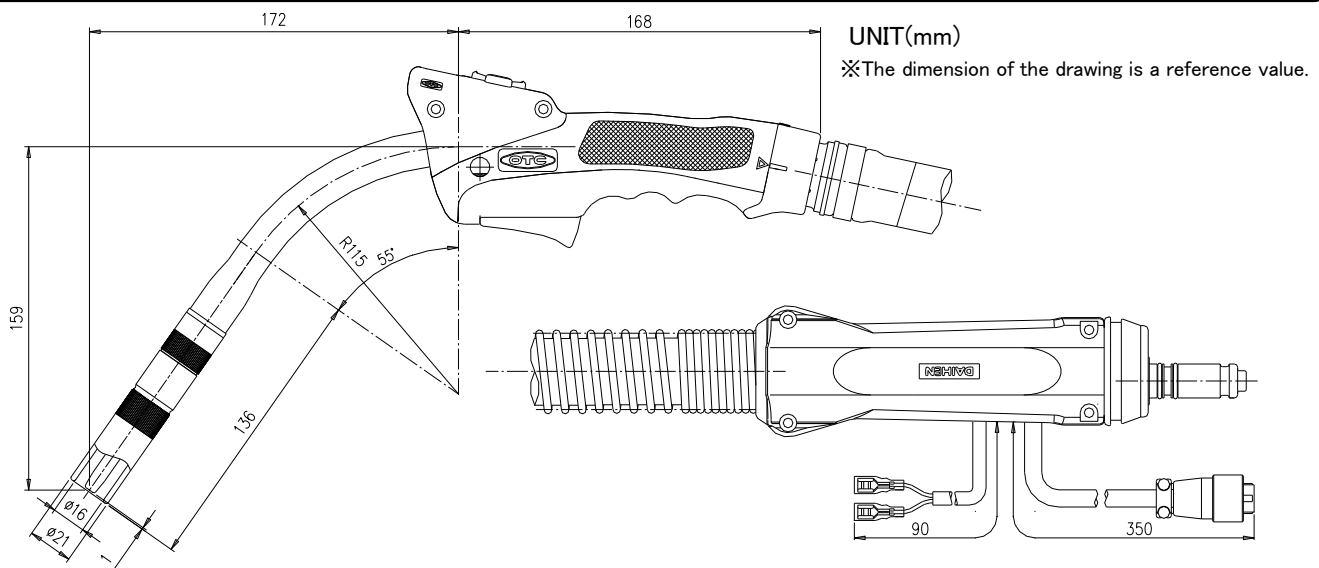

**DAIHEN Corporation**  
4-1, Koyochi-nishi,  
Higashinada-ku, Kobe,  
Hyogo 658-0033, Japan  
Phone: +81-78-275-2006,  
Fax: +81-78-845-8159

**DAIHEN Inc.**  
1400 Blauser Drive Tipp City,  
Ohio 45371, USA  
Phone: +1-937-667-0800,  
Fax: +1-937-667-0885

**OTC DAIHEN EUROPE GmbH**  
Krefelder Strasse 677,  
D-41066 Mönchengladbach,  
Germany  
Phone: +49-2161-6949710,  
Fax: +49-2161-6949711

**OTC Industrial (Shanghai) Co.,Ltd.**  
6F, Building B,ORIENTO Plaza,  
388 North Fuquan Road, Changning  
District,Shanghai, China 200335  
Phone: +86-21-5882-8633,  
Fax: +86-21-5882-8846

**OTC (Taiwan) Co.,Ltd.**  
2F No.153, Huanbei Rd.,  
Chung Li City, Taoyuan  
Hsien, Taiwan  
Phone: +886-3-461-3962,  
Fax: +886-3-434-2394

**OTC DAIHEN INDIA Pvt.Ltd.**  
V.M.TOWER, Plot No.54A,  
Ground Floor Unit-1, Sector-18,  
Gurgaon-122015 Haryana, India  
Phone:+91 124-4239368,  
Fax:+91 124-4300820

**DAIHEN Korea Co., Ltd.**  
11B/L Hyeongok Industrial  
Complex, 463-1 Hyeongok-ri,  
Cheongbuk-myeon, Pyeongtaek,  
Gyeonggi-do, 451-831,  
Republic of Korea  
Phone: +82-31-686-7445,  
Fax: +82-31-686-7464

**OTC DAIHEN Asia Co.,Ltd.**  
23/43, 16th F1.Sorachai Building,  
23 Soi 63 Sukhumvit Road,  
Klongtonnua, Wattana, Bangkok  
10110, Thailand  
Phone: +66-2-714-3201,  
Fax: +66-2-714-3204

**PT.OTC DAIHEN INDONESIA**  
Blok G1A-20, Jl. Kenari II,  
Delta Silicon V,  
Lippo Cikarang Industrial  
Park, Bekasi 17550 Indonesia  
Phone:+6221-2957-7566,  
Fax:+6221-2957-7567