



**OWNER'S      MANUAL**  
**FOR**  
**TIG TORCH**

**MODEL:    AWD-17 (4m)    H1172**  
**AWD-17 (8m)    H1173**

**DO NOT DESTROY**

**IMPORTANT:** Read and understand the entire contents of this manual, with special emphasis on the safety material throughout the manual, before installing, operating, or maintaining this equipment. This equipment and this manual are for use only by persons trained and experienced in the safety operation of welding equipment. Do not allow untrained persons to install, operate or maintain this equipment. Contact your distributor if you do not fully understand this manual.

**DAIHEN Corporation** WELDING PRODUCTS DIVISION

August 31, 2005

**Upon contact, advise MODEL and MANUAL NO.**

Notice : Machine export to Europe

This product does not meet the requirements specified in the EC Directives which are the EU safety ordinance that was enforced starting on January 1, 1995. Please make sure that this product is not allowed to bring into the EU after January 1, 1995 as it is.

The same restriction is also applied to any country which has signed the EEA accord.



Please ask us before attempting to relocate or resell this product to or in any EU member country or any other country which has signed the EEA accord.

CONTENTS

1. SAFETY INFORMATION .....	2
2. ARC WELDING SAFETY PRECAUTIONS .....	2
3. NOTICE AT OPERATION .....	8
4. CHECK OF PACKAGE CONTENT .....	9
5. WELDING PREPARATION .....	9
6. PARTS LIST .....	12
7. SPECIFICATIONS .....	16

## 1. SAFETY INFORMATION

The following safety alert symbols and signal words are used throughout this manual to identify various hazards and special instructions.

 <b>WARNING</b>	<b>WARNING</b> gives information regarding possible personal injury or loss of life.
 <b>CAUTION</b>	<b>CAUTION</b> refers to minor personal injury or possible equipment damage.

## 2. ARC WELDING SAFETY PRECAUTIONS

 <b>WARNING</b>	
<b>ARC WELDING can be hazardous.</b>	
<b>1. PROTECT YOURSELF AND OTHERS FROM POSSIBLE SERIOUS INJURY OR DEATH.</b>	
Be sure to:	
<ul style="list-style-type: none"> <li>• Keep children away.</li> <li>• Keep pacemaker wearers away until consulting a doctor.</li> </ul>	
<b>2. Read and understand the summarized safety information given below and the original principal information that will be found in the PRINCIPAL SAFETY STANDARDS.</b>	
<b>3. Have only trained and experienced persons perform installation, operation, and maintenance of this equipment.</b>	
<b>4. Use only well maintained equipment. Repair or replace damaged parts at once.</b>	
<b>ARC WELDING is safe when precautions are taken.</b>	

## 2. ARC WELDING SAFETY PRECAUTIONS (continued)

	<p><b>ELECTRIC SHOCK can kill.</b></p>
<p>Touching live electrical parts can cause fatal shocks or severe burns. The electrode and work circuits are electrically live whenever the output is on. The power line and internal circuits of this equipment are also live when the line disconnect switch is on. When arc welding all metal components in the torch and work circuits are electrically live.</p> <ol style="list-style-type: none"> <li>1. Do not touch live electrical parts.</li> <li>2. Wear dry insulating gloves and other body protection that are free of holes.</li> <li>3. Insulate yourself from work and ground using dry insulating mats or covers.</li> <li>4. Be sure to disconnect the line disconnect switch before installing, changing torch parts or maintaining this equipment.</li> <li>5. Properly install and ground this equipment according to its Owner's Manual and national, state, and local codes.</li> <li>6. Keep all panels and covers of this equipment securely in place.</li> <li>7. Do not use worn, damaged, undersized, or poorly spliced cables.</li> <li>8. Do not touch electrode and any metal object if POWER switch is ON.</li> <li>9. Do not wrap cables around your body.</li> <li>10. Turn off POWER switch when not in use.</li> </ol>	

	<p><b>ARC RAYS can burn eyes and skin: FLYING SPARKS AND HOT METAL can cause injury. NOISE can damage hearing.</b></p>
<p>Arc rays from the welding process produce intense heat and strong ultraviolet rays that can burn eyes and skin.</p> <p>Noise from some arc welding can damage hearing.</p> <ol style="list-style-type: none"> <li>1. Wear face shield with a proper shade of filter (See ANSI Z 49.1 listed in PRINCIPAL SAFETY STANDARDS) to protect your face and eyes when welding or watching a welder work.</li> <li>2. Wear approved safety goggles. Side shields recommended.</li> <li>3. Use protective screens or barriers to protect others from flash and glare: warn others not to look at the arc.</li> <li>4. Wear protective clothing made from durable, flame-resistant material (wool and leather) and foot protection.</li> <li>5. Use approved earplugs or earmuffs if noise level is high.</li> <li>Chipping and grinding can cause flying metal. As welds cool, they can throw off slag.</li> <li>6. Wear approved face shield or safety goggles. Side shields recommended.</li> <li>7. Wear proper body protection to protect skin.</li> </ol>	

2. ARC WELDING SAFETY PRECAUTIONS (continued)

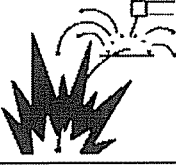
	<p><b>WELDING can cause fire and explosion.</b></p>
<p>Sparks and spatter fly off from the welding arc. The flying sparks and hot metal, spatter, hot base metal, and hot equipment can cause fire and explosion. Accidental contact of electrode or welding wire to metal object can cause sparks, overheating, or fire.</p> <ol style="list-style-type: none"> <li>1. Protect yourself and others from flying sparks and hot metals.</li> <li>2. Do not weld where flying sparks can strike flammable material.</li> <li>3. Remove all flammables within 10m (33ft) of the welding arc. If this is not possible, tightly, cover them with approved covers.</li> <li>4. Be alert that welding sparks and hot metals from welding can easily pass through cracks and openings into adjacent areas.</li> <li>5. Watch for fire, and keep a fire extinguisher nearby.</li> <li>6. Be aware that welding on a ceiling, floor, bulkhead, or partition can ignite a hidden fire.</li> <li>7. Do not weld on closed containers such as tanks or drums.</li> <li>8. Connect base metal side cable as close to the welding area as possible to prevent the welding current from traveling along unknown paths and causing electric shock and fire hazards.</li> <li>9. Remove stick electrode from holder or cut off welding wire at contact tip when not in use.</li> <li>10. Do not use the welding power source for other than arc welding.</li> <li>11. Wear oil-free protective garments such as leather gloves, a heavy shirt, cuffless trousers, boots, and a cap.</li> <li>12. A loose cable connection can cause sparks and excessive heating.</li> <li>13. Tighten all cable connections.</li> <li>14. When there is an electrical connection between a work piece and the frame of wire feeder or the wire reel stand, arc may be generated and cause damage by a fire if the wire contacts the frame or the work piece.</li> </ol>	

	<p><b>FUMES AND GASES can be hazardous to your health.</b></p>
<p>Arc welding produce fumes and gases. Breathing these fumes and gases can be hazardous to your health.</p> <ol style="list-style-type: none"> <li>1. Keep your head out of the fumes. Do not breathe the fumes.</li> <li>2. Ventilate the area and/or use exhaust at the arc to remove welding fumes and gases.</li> <li>3. If ventilation is poor, use an approved air-supplied respirator.</li> <li>4. Read the Material Safety Data Sheets (MSDS) and the manufacturer's instructions on metals, consumables, coatings, and cleaners.</li> <li>5. Do not weld or cut in locations near degreasing, cleaning, or spraying operations. The heat and rays of the arc can react with vapors to form highly toxic and irritating gases.</li> <li>6. Work in a confined space only if it is well ventilated, or while wearing an air-supplied respirator. Shielding gases used for welding can displace air causing injury or death. Be sure the breathing air is safe.</li> </ol>	

## 2. ARC WELDING SAFETY PRECAUTIONS (continued)

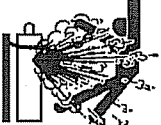
	<b>CYLINDER can explode if damaged.</b>
<p><b>A shielding gas cylinder contains high-pressure gas. If damaged, a cylinder can explode. Since gas cylinders are normally part of the welding process, be sure to treat them carefully.</b></p> <ol style="list-style-type: none"><li><b>1. Use only correct shielding gas cylinders, gas regulator, hoses, and fittings designed for the specific application; maintain them in good condition.</b></li><li><b>2. Protect compressed gas cylinders from excessive heat, mechanical shock, and arcs.</b></li><li><b>3. Keep the cylinder upright and securely chained to a stationary support or a rack to prevent falling or tipping.</b></li><li><b>4. Keep cylinders away from any welding or other electrical circuit.</b></li><li><b>5. Never touch cylinder with welding electrode.</b></li><li><b>6. Read and follow instructions on compressed gas cylinders, associated equipment, and the CGA publication P-1 listed in PRINCIPAL SAFETY STANDARDS.</b></li><li><b>7. Turn face away from valve outlet when opening cylinder valve.</b></li><li><b>8. Keep protective cap in place over valve except when gas cylinder is in use or connected for use.</b></li><li><b>9. Do not disassemble or repair the gas regulator except for the person authorized by the manufacturer of them.</b></li></ol>	

	<b>Rotating parts may cause injuries. Be sure to observe the following.</b>
<p><b>If hands, fingers, hair or clothes are put near the fan's rotating parts or wire feeder's feed roll, injuries may occur.</b></p> <ol style="list-style-type: none"><li><b>1. Do not use this equipment if the case and the cover are removed.</b></li><li><b>2. When the case is removed for maintenance/inspection and repair, certified or experienced operators must perform the work. Erect a fence, etc. around this equipment to keep others away from it.</b></li><li><b>3. Do not put hands, fingers, hair or clothes near the rotating fans or wire feed roll.</b></li></ol>	

2. ARC WELDING SAFETY PRECAUTIONS (continued)

	<p>ARC WELDING work areas are potentially hazardous.</p>
<p><b>FALLING or MOVING machine can cause serious injury.</b></p> <ol style="list-style-type: none"> <li>5. When hanging the welding power source by a crane, do not use the carrying handle.</li> <li>6. Put the welding power source and wire feeder solidly on a flat surface.</li> <li>7. Do not pull the welding power source across a floor laid with cables and hoses.</li> <li>8. Do not put wire feeder on the welding power source.</li> <li>9. Do not put the welding power source and wire feeder where they will pit or fall.</li> </ol> <p><b>WELDING WIRE can cause puncture wounds.</b></p> <ol style="list-style-type: none"> <li>10. Do not press gun trigger until instructed to do so.</li> <li>11. Do not point gun toward any part of the body, other people, or any metal when threading welding wire.</li> </ol>	

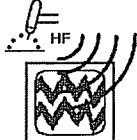
	<p>This equipment uses high frequency for arc starting.</p>
<p><b>High-frequency may enter nearby units as shown below, causing electromagnetic trouble.</b></p> <ul style="list-style-type: none"> <li>* Input cables, signal cables, telephone cables</li> <li>* Radio sets, TV sets</li> <li>* Computers and other control equipment</li> <li>* Industrial detectors and safety units</li> <li>* Pacemakers, hearing-aid sets</li> </ul> <p><b>For preventing electromagnetic trouble,</b></p> <ol style="list-style-type: none"> <li>1. Make the cable as shortest as possible.</li> <li>2. Install cables along the floor or the ground as close as possible.</li> <li>3. Put the base metal side cable together with the torch side cable.</li> <li>4. Do not use a common base metal ground with other machines.</li> <li>5. Tightly close all of the doors and covers of this equipment, and secure them.</li> <li>6. Do not press the torch switch other than when ready to start the arc.</li> <li>7. When electromagnetic trouble occurs, take the measures shown in this instruction manual until trouble is corrected.</li> </ol> <p>Please contact OTC-DAIHEN , when necessary.</p> <ol style="list-style-type: none"> <li>8. Pacemaker wearers must not come near this equipment during operation until consulting your doctor.</li> </ol> <p>Operation of the pacemakers will be affected badly by high frequency.</p>	



## PRINCIPAL SAFETY STANDARDS

Arc welding equipment – Installation and use, Technical Specification  
IEC 62081, from International Electro technical Commission

Arc welding equipment Part 1: Welding power sources IEC 60974-1, from International Electro technical  
Commission

Safety in Welding and Cutting, ANSI Standard Z49.1, from American Welding Society.

Safety and Health Standards, OSHA 29 CFR 1910, from Superintendent of Documents, U.S. Government  
Printing Office.

Recommended Practices for Plasma Arc Cutting, American Welding Society Standard AWS C5.2, from  
American Welding Society.

Recommended Safe Practices for the Preparation for Welding and Cutting of Containers That Have Held  
Hazardous Substances, American Welding Society Standard AWS F4.1, from American Welding Society.

National Electrical Code, NFPA Standard 70, from National Fire Protection Association.

Safe Handling of Compressed Gases in Cylinders, CGA Pamphlet P-1, from Compressed Gas Association.

Code for Safety in Welding and Cutting, CSA Standard W117.2, from Canadian Standards Association,  
Standards Sales.

Safe Practices For Occupation And Educational Eye And Face Protection, ANSI Standard Z87.1, from  
American National Standards Institute.

Cutting And Welding Processes, NFPA Standard 51B, from National Fire Protection Association.

NOTE: The codes listed above may be improved or eliminated. Always refer to the updated codes.

### 3. NOTICE AT OPERATION

#### 3.1 Rated duty cycle

 CAUTION

● Use at the rated duty cycle or under. If exceeding the rated duty cycle, the welder may be deteriorated and burned.

● Rated duty cycle: 150A, 50% (DC)  
130A, 50% (AC)

● The duty cycle of 50% means the way the machine is rested for 5 minutes after 5 minutes of continuous welding at the rated current.

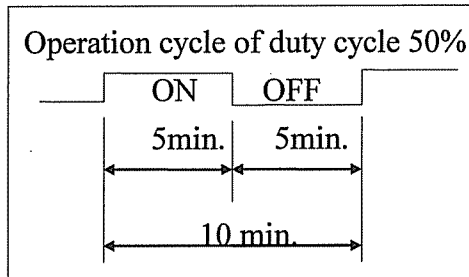

● If exceeding the rated duty cycle, temperature rise of welding power source and torch exceed the allowable temperature. And it causes the burning.

#### 3.2 Cable hose

 CAUTION

● Do not bent cable hose excessively, touch high temperature parts, or put heavy stuff, or welding torch might be burned out.

#### 3.3 Replacement of parts

 CAUTION

● Be sure to observe the followings for preventing burning.

● At welding, never touch the high temperature parts of nozzle and electrode directly.

● At welding, use the protection goods.

● The replacing of parts of welding torch should be done after cooling down.

 CAUTION

● In case of parts are damaged, replace them with new parts for safety and quality.

● Be sure to use the OTC's genuine parts.

 CAUTION

● When polishing of electrode, wear protection glasses to protect your eyes.

● For safety polishing operation, follow the safety instructions for grinder and electrode polishing machine.

#### 4. CHECK OF PACKAGE CONTENT

Check the quantity of parts when opening the package.

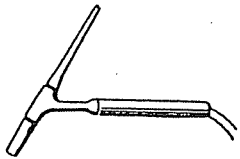
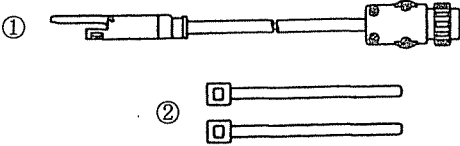
Welding torch	Accessories		
 AWD-17 TIG Torch 1set (Ceriated tungsten electrode $\phi$ 1.6 built-in)			
	Part name	Specifications	Quantity
1. Torch switch	4m, 8m	1	
2. Tie up band	W4.0 x L186(mm)	2	

#### 5. WELDING PREPARATION

##### 5.1 Connection to welding power source

⚠ CAUTION
● Tighten the connections. Looseness may cause fire or burn because of heat.
● Refer to owner's manual of each welding power source, and connect rightly.

##### 5.2 Selection of electrode

Pure tungsten electrode (with white mark), ceriated tungsten electrode (contained 2% cerium, with gray mark) and thoriated tungsten electrode (contained 2% thorium, with red mark) are usually used.

Welding method	Electrode material	Work material
DC TIG arc welding	Ceriated tungsten Thoriated tungsten	Stainless steel, Mild steel, Brass, High carbon steel, Cast iron, Copper, Titanium, Silver
AC TIG arc welding	Ceriated tungsten Pure tungsten Thoriated tungsten	Aluminum, Aluminum casting, Magnesium, Magnesium casting

Note: The table above shows only typical work materials and electrode materials.

##### 5.3 Selection of electrode diameter

Electrode diameter (mm $\phi$ )	Welding current (A)				
	DC TIG welding (Negative electrode)		AC TIG welding		
	Ceriated tungsten	Thoriated tungsten	Ceriated tungsten	Pure tungsten	Thoriated tungsten
0.5	—	1~20	—	30	50
1.0	—	1~80	—	10~60	20~80
1.6	5~150	5~150	40~130	20~100	40~130
2.0	—	10~200	—	30~130	50~180
2.4	20~250	20~250	70~220	50~160	70~220

Note: Current range above shows that usable current limit for wire diameter.

5.4 Selection of nozzle

● Refer to the table below to get enough shield by argon gas and use a right nozzle according to welding current

Welding current (A)	DC welding		AC welding	
	Nozzle No.	Gas flow rate (ℓ / min.)	Nozzle No.	Gas flow rate (ℓ / min.)
10~100	4, 5, 6	4~5	5, 6	6~8
101~150	4, 5, 6	5~7	6, 7	7~10

Notes:

(1) Relation between nozzle number and inside diameter

Nozzle No.	4	5	6	7	5L	7L
Inside diameter (mm)	6.5	8	9.5	11	8	11

(2) Nozzle for gas lens

Gas lens controls the flow of shield gas at a uniform pace.  
 Gas lens has following advantages.

- Even few gas flow rate gets perfect shield effect.
- The tip of tungsten is adjustable and it makes welding operation possible at narrow place and reduce damages of nozzle. Gas nozzle is very useful for high quality welding and complicated welding.

5~7 times as long as usual length.

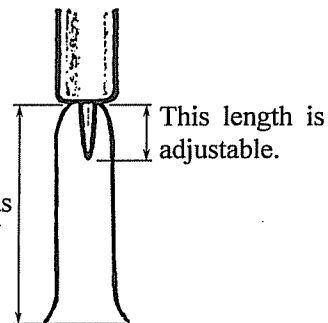

5.5 Selection of collet and collet body

● Collet and collet body are for power supply and electrode holding. They are classified into two kinds by whether the gas lens is used or not. In addition, there are five kinds of each one according to the electrode diameter. Select proper collet and collet body according to the size.

● Attach the insulator when using the collet body with the gas lens is used.

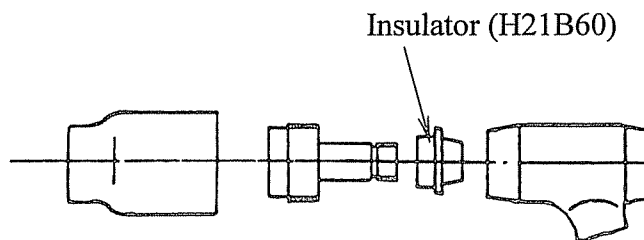

5.6 How to use a cap (short) and nozzle L (Long) (Optional accessory)

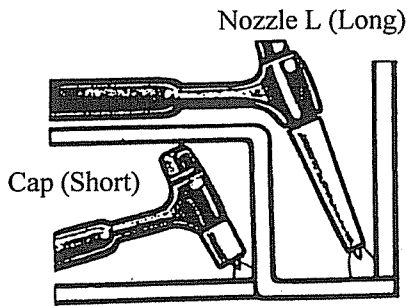

●Select according to the welding place and the shape of base metal. By using them, larger limit welding is possible.

For ordering, refer to “6.2 Optional accessories.”

5.7 Assembling of torch body

●For assembling, follow the numbers below.

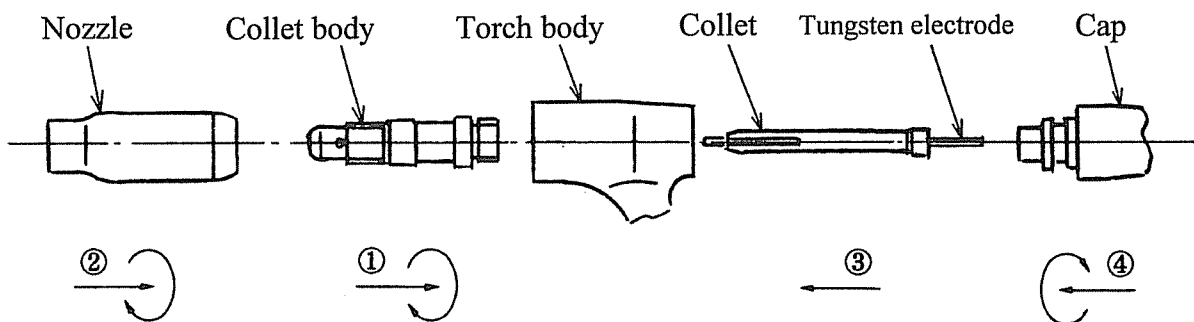

⚠ CAUTION

●Securely tight the collet body and cap. If loosen it, it can be the cause of burning and overheating.

⚠ CAUTION

●Use electrode stick 5~10mm out from tip of nozzle. If the tip of electrode is inside nozzle, nozzle might be damaged by heat of arc.

5.8 Assembling and disassembling of handle

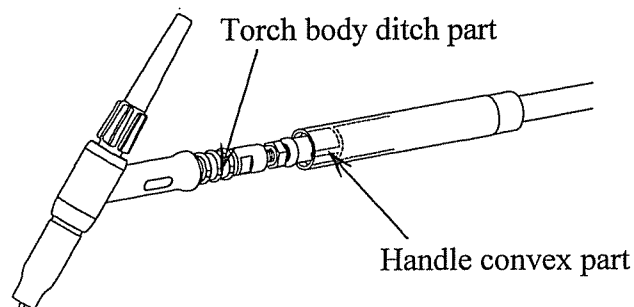

! CAUTION

●For assembling of handle, set the handle lug part to torch body slot part, and insert it.

●Do not screw handle when assembling and disassembling. If screw handle, torch body might be damaged.

## 6. PARTS LIST

If parts are required for replacement, direct order involving Description and Part No. to our sales agent or OTC's office directly. For optional accessories, refer to 5.2.

## 6.1 Standard parts

No.	Part No.	Description	Q'ty	Remarks
1	H81B00	Torch body	1	Include 1-1, 1-2
1-1	H500B04	Insulator	(1)	
1-2	H500B05	Gasket	(1)	
2	H950C03	Collet (1.6)	1	Copper type (split)
3	H950C13	Collet body (1.6)	1	Copper type
4	H21B20	Nozzle (No.5)	1	Internal diameter 8mm
5	0870-016	Ceriated tungsten electrode	1	$\phi 1.6 \times 150\text{mm}$
6	H83C00	Cap (Long)	1	Include 6-1
6-1	3570-007	"O" ring	(1)	JISW1516-7
7	H1164G01	Rubber cover	1	
8	H948E01	Handle	1	
9	H1172E00	Adapter	1	
10	H1164F00	Gas hose	1	
(Cable length: 4m)				
11	H1172D00	Power cable hose	1	
12	K1108A00	Torch switch	1	Include 12-1, 12-2
12-1	K1108C00	Body assembly	(1)	
12-2	4730-001	Plug	(1)	2P
(Cable length: 8m)				
11	H1173D00	Power cable hose	1	
12	K1109A00	Torch switch	1	Include 12-1, 12-2
12-1	K1108C00	Body assembly	(1)	
12-2	4730-001	Plug	(1)	2P

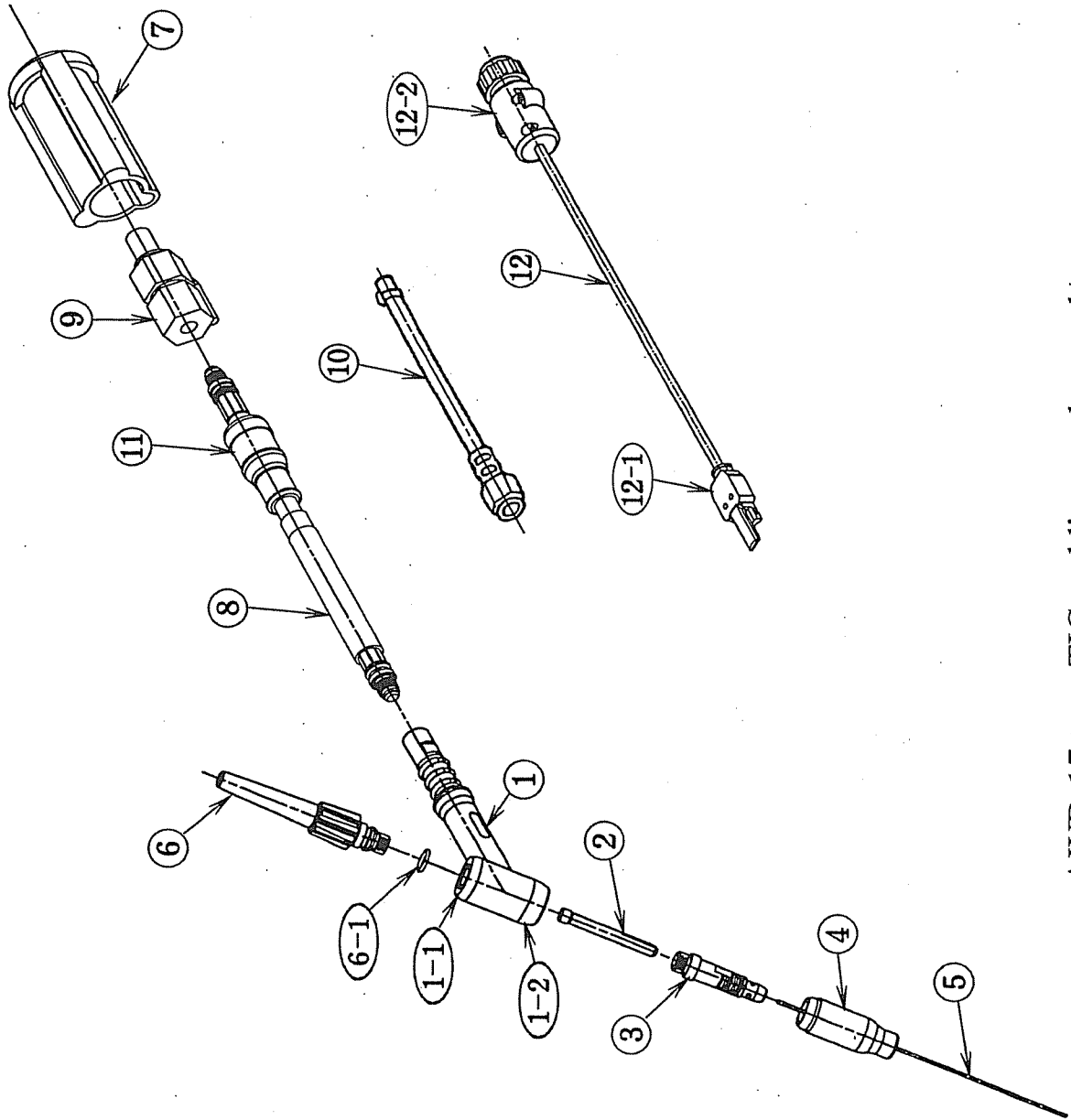

AWD-17 type TIG welding torch parts layout

## 6.2 Optional accessories

## • Collet

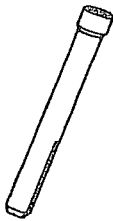
	Electrode diameter	Part No.		
		Copper type (split)	Copper alloy type (quartered)	Steel type (quartered)
	0.5	—	H21B13	H64B26
	1.0	H950C02	H21B14	H64B27
	1.6	H950C03	H21B15	H64B28
	2.0	H950C04	H21B64	H64B30
	2.4	H950C05	H21B16	H64B29

Note Collet for 0.5 and for 1.0 is split type.

## • Colletbody

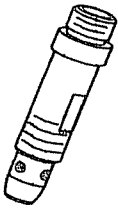
	Electrode diameter	Part No.		
		Copper type	Copper alloy type	Steel type
	0.5	H950C11	H21B08	H81C01
	1.0	H950C12	H21B09	H81C02
	1.6	H950C13	H21B10	H81C03
	2.0	H950C14	H21B66	H81C05
	2.4	H950C15	H21B11	H81C04

## • Tungsten electrode

 Length 150 mm	Electrode diameter	Part No.		
		Ceriated tungsten	Thoriated tungsten	Pure tungsten
	0.5	—	0831-005	0830-005
	1.0	—	0831-010	0830-010
	1.6	0870-016	0831-016	0830-016
	2.0	—	0831-020	0830-020
	2.4	0870-024	0831-024	0830-024

## • Nozzle

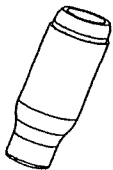
	Nozzle	Part No.	Remarks
	4	H21B19	Internal diameter 6.5mm
	5	H21B20	Internal diameter 8mm
	6	H21B21	Internal diameter 9.5mm
	7	H21B22	Internal diameter 11mm

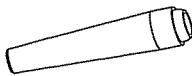

• Nozzle (long)

	Nozzle	Part No.	Remarks
	5L	H21B38	Internal diameter 8mm
	7L	H21B39	Internal diameter 11mm

• Arc spot specification

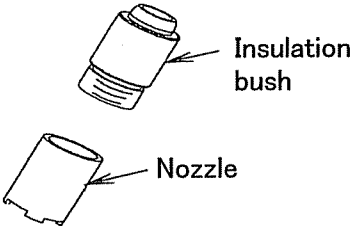
	• Insulation bush		
	<u>Part No.</u>		
	<u>H21B70</u>		
	• Nozzle		
<u>Part No.</u>		<u>Remarks</u>	
<u>H21B71</u>		<u>Internal diameter 18mm</u>	

• Gas lens specification

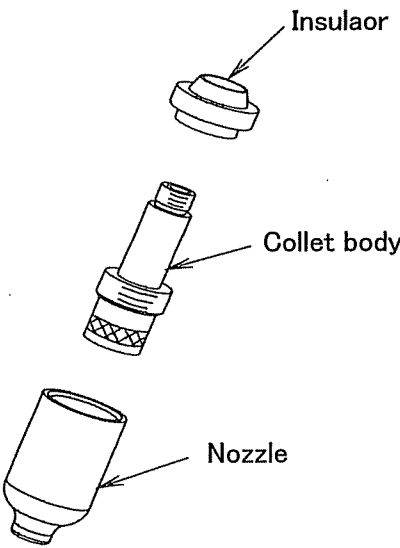
	• Insulator		
	<u>Part No.</u>		
	<u>H21B60</u>		
	• Collet body		
	<u>Electrode diameter</u>	<u>Part number</u>	
	0.5	H21B50	
1.0	H21B51		
1.6	H21B52		
2.4	H21B53		
• Nozzle			
<u>Nozzle No.</u>	<u>Part number</u>	<u>Remarks</u>	
4	H21B40	Internal diameter 6.5mm	
5	H21B41	Internal diameter 8mm	
6	H21B42	Internal diameter 9.5mm	
7	H21B43	Internal diameter 11mm	
8	H21B44	Internal diameter 12.7mm	

• Cap (short)

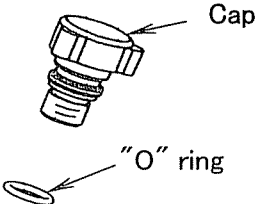
	• Cap (short)		
	<u>Part No.</u>		<u>Remarks</u>
	<u>H83D00</u>		<u>Including "O" ring</u>
	• "O" ring		
	<u>Part No.</u>		<u>Remarks</u>
	<u>3570-007</u>		<u>JISW-1516-7</u>

7. SPECIFICATIONS

7.1 Specifications

Model		AWD-17	
Torch type		60° Angle type	
Max. applicable current	DC	150A	
	AC	130A	
Rated duty cycle		50%	
Usable electrode		(φ 0.5), (φ 1.0), φ 1.6, (φ 2.0), (φ 2.4)	
Electrode material		Ceriated tungsten (Thoriated tungsten , Pure tungsten)	
Cooling method		Air cooling	
Cable length		4m, 8m	
Mass.	Include cable	4m	1.3kg
		8m	2.1kg

Note: In case of using electrode size of “( )”, optional accessories are required.

7.2 External view

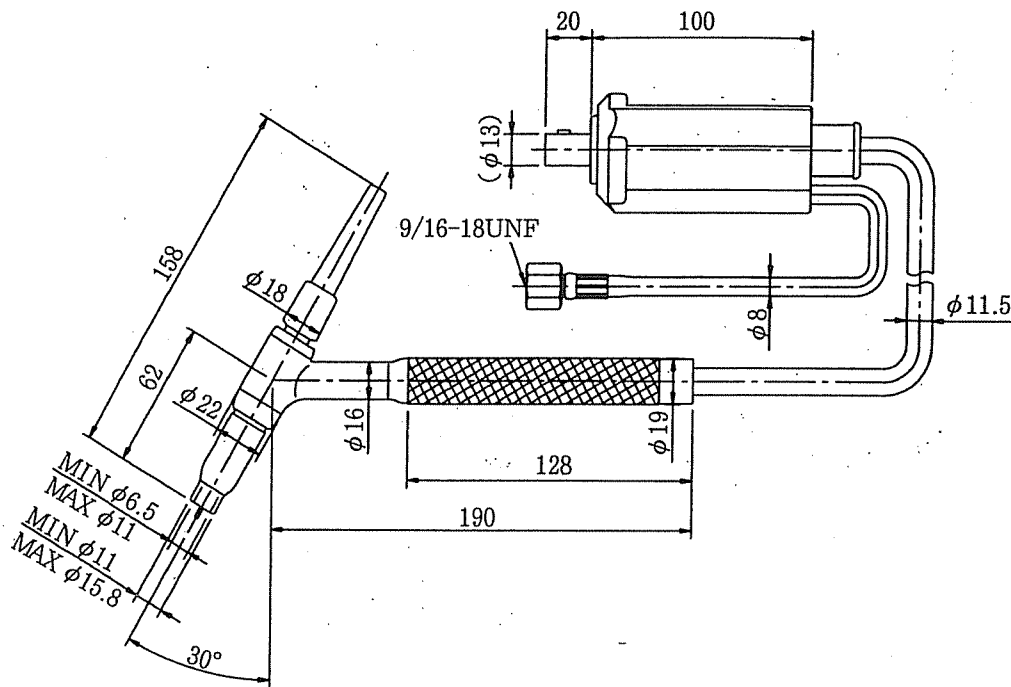



**DAIHEN Corporation**

5-1, Minamisenrioka, Settsu-shi, Osaka 566-0021, Japan

Phone: +81-6-6317-2506, Fax: +81-6-6317-2583

**DAIHEN, INC.**

DAYTON OFFICE

1400 Blausser Drive

Tipp City, Ohio 45371, USA

Phone: +1-937-667-0800, Fax: +1-937-667-0885

**OTC DAIHEN EUROPE GmbH.**

Krefelder Str. 677, D-41066 Mönchengladbach, F.R. GERMANY

Phone: +49-2161-69-49710, Fax: +49-2161-69-49711

**OTC Industrial (Shanghai) Co.,Ltd.**

7G Majesty Building, 138 Pu Dong Da Dao Shanghai

The People's Republic of China

Post Code: 200120

Phone: +86-21-58828633, Fax: +86-21-58828846

**OTC (Taiwan) Co.,Ltd.**

No. 63-4, Nan Yuan 2 Rd., Chung Li,

Taoyuan Hsien, Taiwan R.O.C.

Phone: +886-3-461-3962, Fax: +886-3-434-2394

**OTC DAIHEN Asia Co.,Ltd.**

60 / 86 Moo 19, Navanakorn Industrial Estate Phase 3,

Klong Nueng, Klong Luang, Pathumthani 12120

Phone: +66-2-909-4163, Fax: +66-2-909-4166

**Upon contact, advise MODEL and MANUAL NO.**