

ED-ARC 100

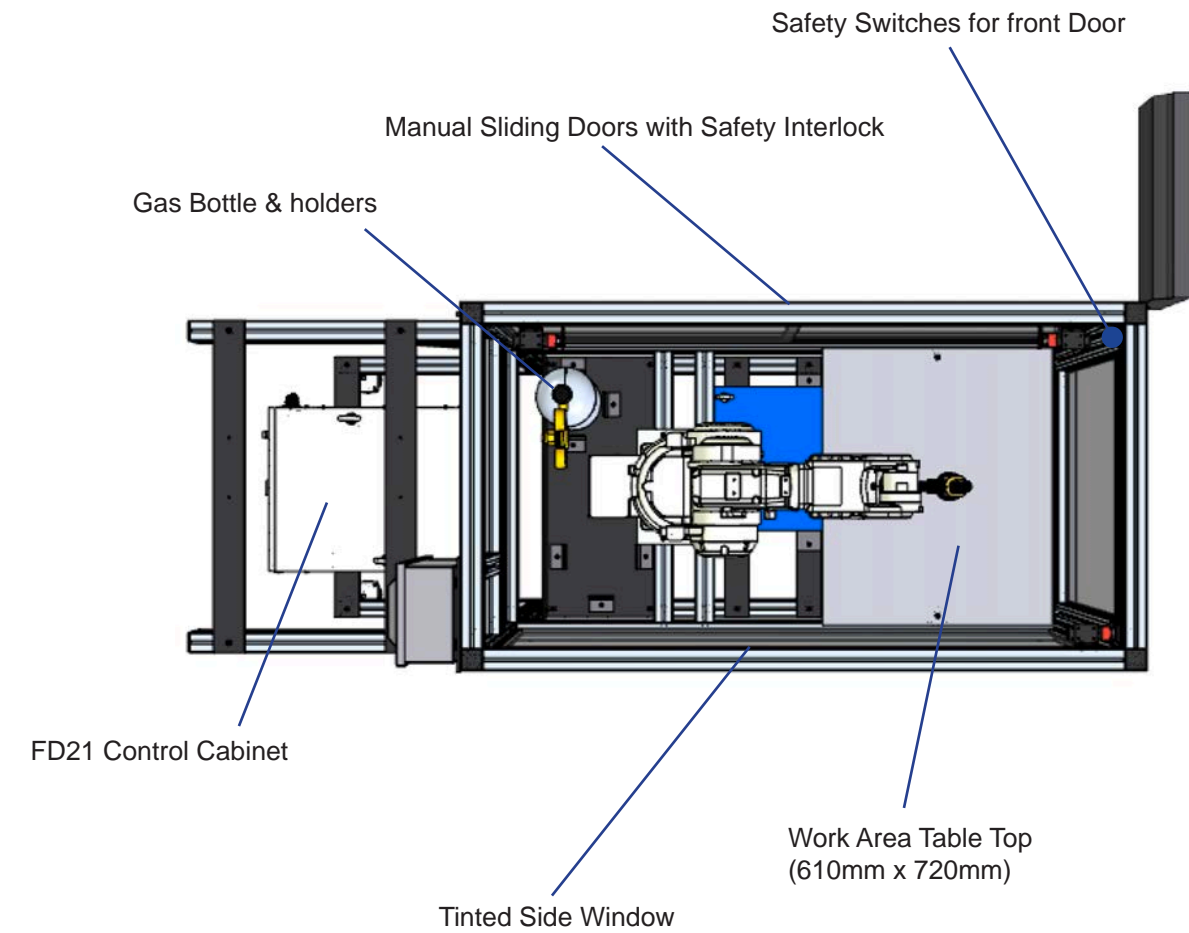
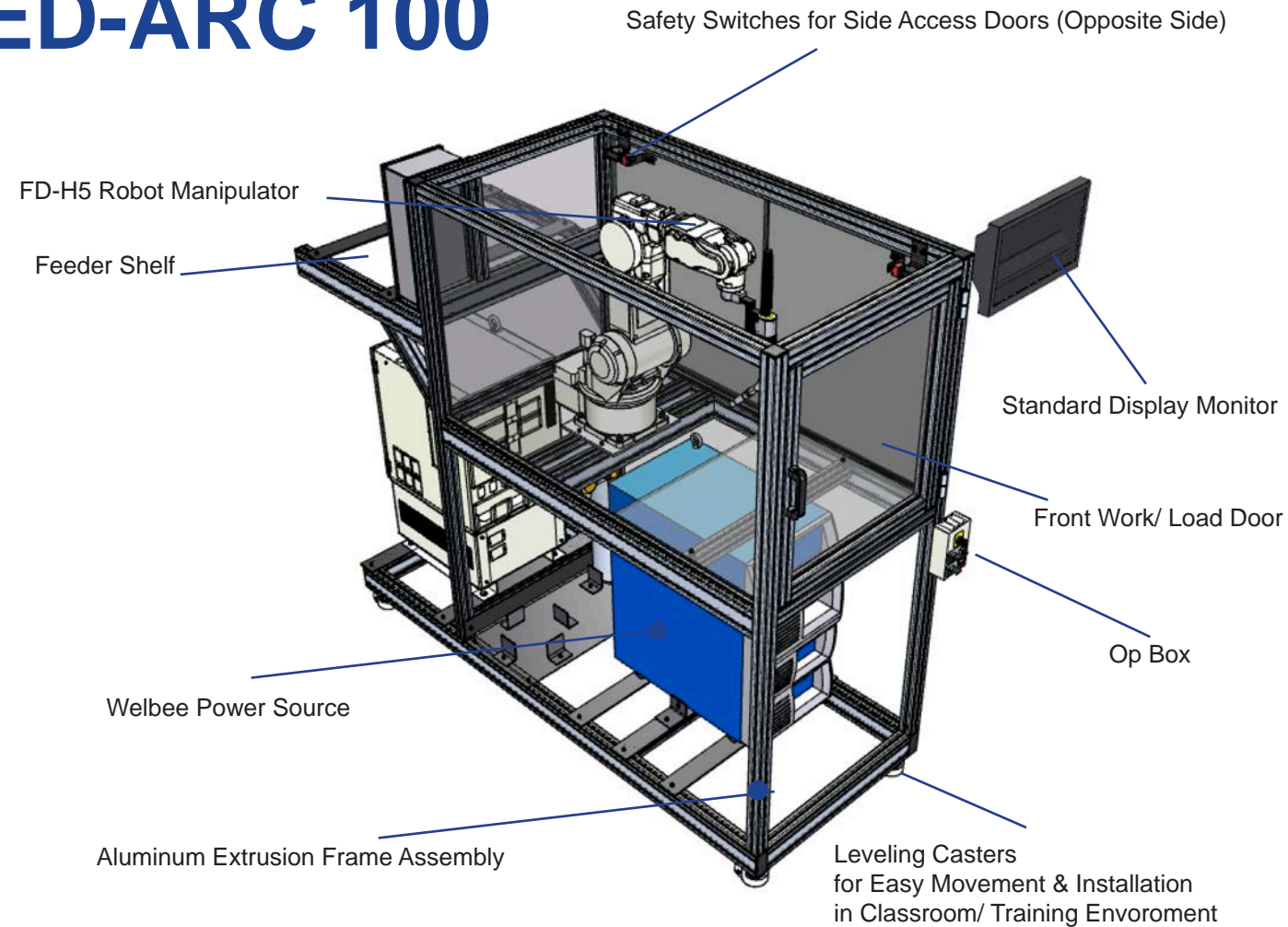

Standard Configuration:

ED-ARC 100

Mobile, fully enclosed arc welding training station with compact robot manipulator (FD-H5)

Details:

- Lightweight aluminum frame and polycarbonate arc flash enclosure
- Flat table top surface with 610mm x 720mm work area
- Height of work area 1177mm
- Maximum payload: 250kg
- Leveling casters for stable installation/easy movement when needed
- Weight – Approx. 550kg
- Front load access door with tinted window and safety interlock
- Side access door with tinted window for load/maintenance and safety interlock
- Tinted panels provide better light in work area for training visibility and operator safety
- Shelf mounted welding power source
- Standard Display Monitor



Specifications

Footprint Dimensions:

Width: 820mm (32.3")
 Height: 2014mm (79.3")
 Depth: 2320 (91.3")

Manipulator Types:

- FD-H5

Available I/O Slots:

32 Inputs/32 Outputs
 (Additional Power Supply needed for Outputs)

Other Options:

- Optional Additional Work Area
 - Adds additional space by adding to the extruded frame and removing the long side panel without sliding doors
 - May require adding a zone kit for station designation