

*Advanced Air Cooled CO<sub>2</sub>/MAG Welding Torch*

# BLUE TORCH

## OWNER'S MANUAL 『Parts List』

WT4000 - SUT . . . 1U5997  
 WT4000 - MUT . . . 1U5998  
 WT4000 - LUT . . . 1U5999

**WT4000 - SUT**  
**WT4000 - MUT**  
**WT4000 - LUT**

### Technical Data

Rated Current : 400A ( CO<sub>2</sub> ) / 350A ( MAG )

Duty Cycle : 60% ( CO<sub>2</sub> ) / 30% ( MAG )

Wire Size : 1.2mm、1.4mm、1.6mm

.045"、.052"、1/16"

( 1.2mm / .045" Tip is standard. )

Torch Length :	3.0m/10ft	4.5m/15ft	6.0m/20ft
----------------	-----------	-----------	-----------

Net Weight :	3.2kg/7.1lb	4.3kg/9.5lb	5.3kg/11.7lb
--------------	-------------	-------------	--------------

Weight at Operating : 1.3kg/2.9lb

Cooling Method : Air Cooled

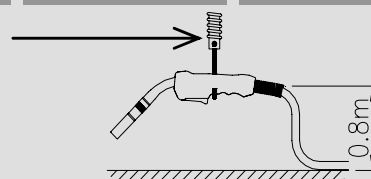

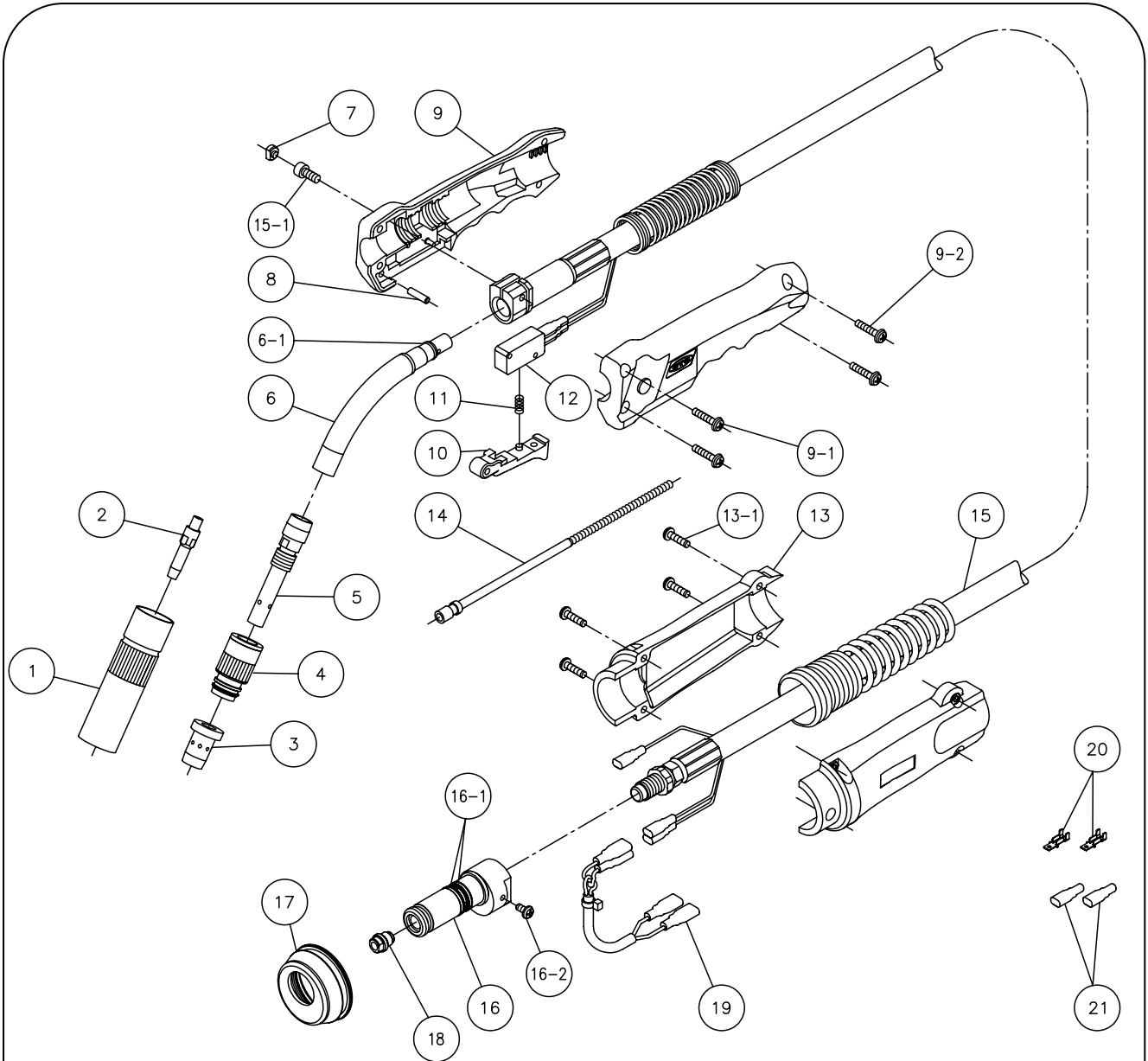

# Standard Parts List



No.	Description	Part No.	Remarks
	Nozzle	U4167H16	I.D.16mm
	Contact Tip	K980C26	1.2mm/.045"
	Orifice	U4167G02	
	Insulator	U4167L00	
	Tip Body	U4167G03	
	Torch Body	U5350B00	R115, 55 °
-1	O-Ring	3574-001	S9
	Cap	U5341G01	
	Flat Pin	U5035G03	
	Handle	U5035G00	
-1	Small Screw	100-0308	M4 x 20
-2	Small Screw	100-0306	M4 x 16
	Trigger	U5035E01	
	Spring	U157E04	
	Micro Switch	4254-137	Dustproof Type
	Cable Support	U5035K00	
-1	Small Screw	100-0306	M4 x 16

No.	Description	Part No.	Remarks
	Liner		
	3.0m/10ft	U4170H02	0.9 ~ 1.2mm / .035" ~ .045"
	4.5m/15ft	U4535G01	1.0 ~ 1.2mm / .040" ~ .045"
	6.0m/20ft	U4172H01	1.2mm / .045"
	Power Cable		
	3.0m/10ft	U5350D00	
	4.5m/15ft	U5351D00	
	6.0m/20ft	U5352D00	
-1	Bolt with hole	100-0310	M5 x 14
	Power Fitting	U5972E00	For "NO.4"
-1	O-Ring	100-0818	AS-014(4D)
-2	Small Screw	100-0297	M4 x 8
	Rubber Sleeve	U5972G01	
	Wire Guide	U5972G02	0.9 ~ 1.2mm / .035" ~ .045"
	Switch Cord	U5972F00	
	Terminal	100-0820	LOM-21T-187
②	Cap	100-0821	253224

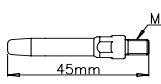
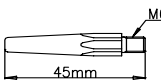
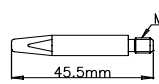
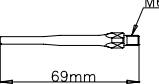
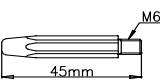
## Optional Parts List

Contact Tip						
	A-Tip (Standard)	T-Tip (High Current)	F-Tip (Low Current)	Long Tip	CW-Tip (Long Life)	Heavy Currnt
Wire Size						
1.2mm (.045")	K980C26 K980C73(For FCW)	K980C19	K980C05	U4167H05	K990E12	U4167H12
1.4mm (.052")	K980C27 K980C74(For FCW)	K980C20	K980C06	-	K990E14	U4167H11
1.6mm (1/16")	K980C28	K980C21	K980C07	-	K990E16	U4167H10

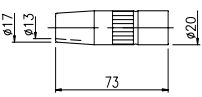
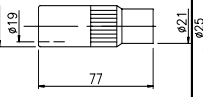
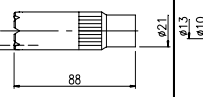
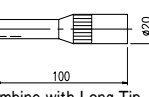
Nozzle			
Low Current	High Current	Arc Spot	Deep and Narrow Space
U4167H01	U4167H02	U4167H03	U4167H04
			
			Combine with Long Tip.

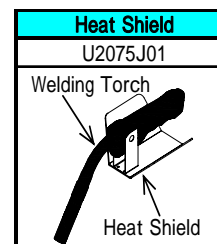

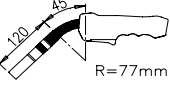
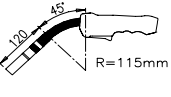
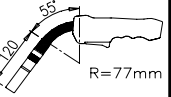
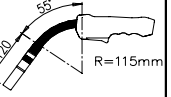
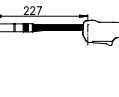
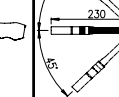
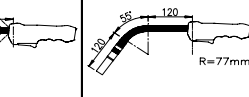
Torch Body						
R77, 45°	R115, 45°	R77, 55°	R115, 55°	Straight	Flexible	Long Neck
U5339B00	U5339C00	U5347B00	U5350B00	U5339J00	U5339L00	U5339N00
						
			Standard		Inner liner is required.	

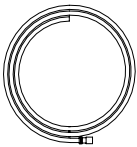
Liner			
Wire Size	Length	Part No.	
1.2 ~ 1.6mm .045" ~ 1/16"	3.0m/10ft	U4173G04	
1.2 ~ 1.6mm .045" ~ 1/16"	4.5m/15ft	U4537G01	
1.2 ~ 1.6mm .045" ~ 1/16"	6.0m/20ft	U4175G04	

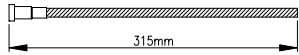
Inner Liner		
Wire Size	Part No.	These are available for the torch bodies above.
1.2 ~ 1.6mm .045" ~ 1/16"	U5003L26	
		

Wire Guide	
Wire Size	Part No.
1.2 ~ 1.6mm .045" ~ 1/16"	U5978G02
	

## External View

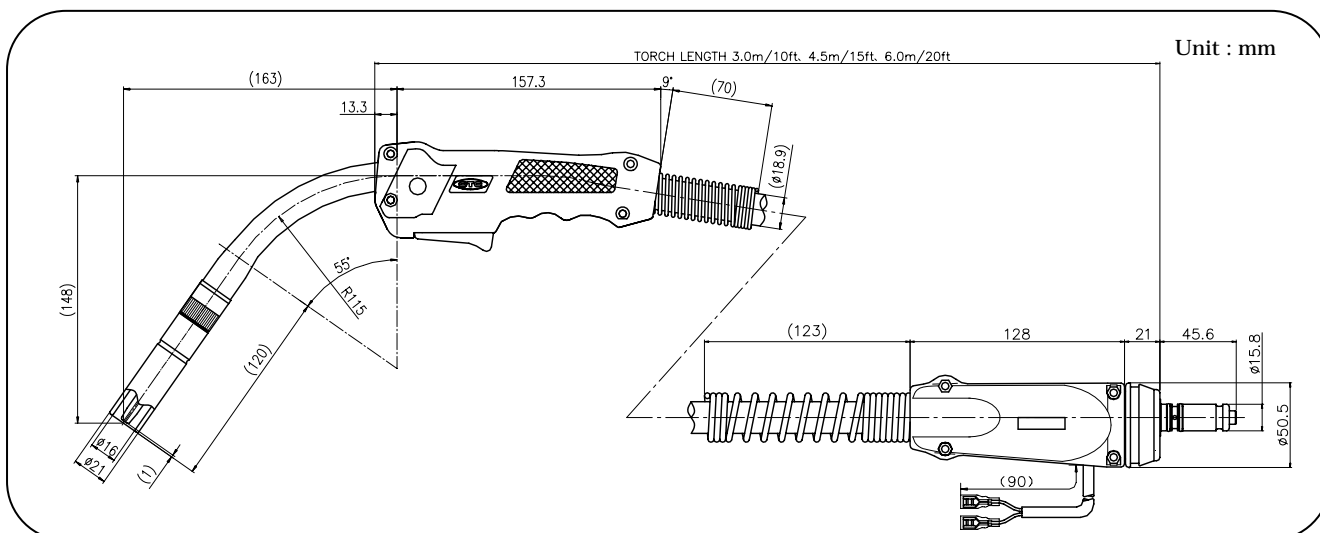

## Torch Type

# WT 4000 - SUT

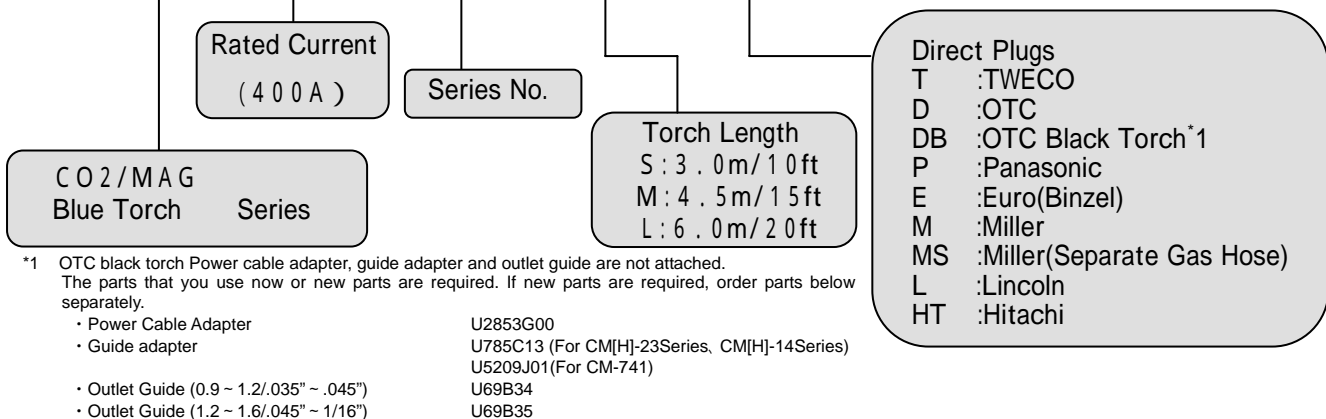

## Product Line of OTC Blue Torch Series

Model	WT3510			WT4000			WT5000		
Rated Current	350A(CO <sub>2</sub> ) / 300A(MAG)			400A(CO <sub>2</sub> ) / 350A(MAG)			500A(CO <sub>2</sub> ) / 450A(MAG)		
Duty Cycle	60%(CO <sub>2</sub> ) / 30%(MAG)			60%(CO <sub>2</sub> ) / 30%(MAG)			60%(CO <sub>2</sub> ) / 30%(MAG)		
Wire Size (mm / inch)	(0.9 / .035") (1.0 / .040") (1.2 / .045") (1.4 / .052")	(1.0 / .040") (1.2 / .045") (1.4 / .052")	1.2 / .045" (1.4 / .052")	1.2 / .045" (1.4 / .052") (1.6 / 1/16")			1.2 / .045" (1.4 / .052") (1.6 / 1/16")		
Torch Length	3.0m / 10ft	4.5m / 15ft	6.0m / 20ft	3.0m / 10ft	4.5m / 15ft	6.0m / 20ft	3.0m / 10ft	4.5m / 15ft	6.0m / 20ft
Net Weight	2.9kg / 6.4lb	3.8kg / 8.4lb	4.7kg / 10.4lb	3.2kg / 7.1lb	4.3kg / 9.5lb	5.3kg / 11.7lb	3.6kg / 7.9lb	4.8kg / 10.6lb	5.9kg / 13.0lb
Cooling Method	Air Cooled			Air Cooled			Air Cooled		

In case of using wire size in the parenthesis, separate sale items are required.

## Attention

Do not pull or move the wire feeder with welding torch, otherwise breaking of the power cable and the cable coating would be tear. If the conductor becomes expose, you may be got electric shocked.

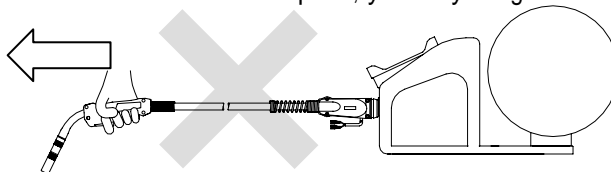

Replace the power cable when it is damaged. Do not disassemble or repair on damping part.

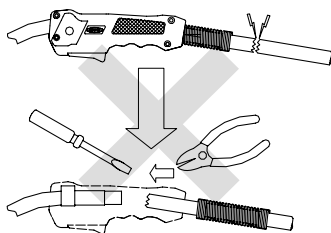

In the case of damaging the O-ring, please replace it. If the damaged O-ring is used as it is, it may cause welding defect.

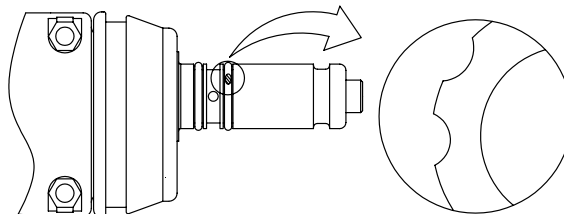

**DAIHEN Corporation**  
 4-1, Koyochonishi,  
 Higashinada-ku, Kobe  
 Hyogo, 658-0033, Japan  
 Phone : +81-78-275-2004  
 Fax : +81-78-845-8158

**DAIHEN, INC.**  
**DAYTON OFFICE**  
 1400 Blauser Drive  
 Tipp City, OH 45371, U.S.A  
 Phone : +1-937-667-0800  
 Fax : +1-937-667-0885

**OTC DAIHEN EUROPE**  
**GmbH.**  
 Krefeder Strasse 677  
 D-41066 Mönchengladbach,  
 F.R .GERMANY  
 Phone : +49-2161-6949710  
 Fax : +49-2161-6949711

**OTC (Taiwan) Co., Ltd.**  
 No.63-4, Nan Yuan 2 Rd.,  
 Chung Li, Taoyuan Hsien,  
 Taiwan R.O.C.  
 Phone : +886-3-461-3962  
 Fax : +886-3-434-2394

**OTC DAIHEN Asia Co., LTD.**  
 60/86 Moo 19, Navanakorn  
 Industrial Estate Phase 3,  
 Klong Nueng, Klong Luang,  
 Pathumthani 12120, Thailand  
 Phone : +66-2-909-4163  
 Fax : +66-2-909-4166

**OTC Industrial (Shanghai)**  
**Co., Ltd.**  
 7G Majisty Buiding, 138 Pu  
 Dong Da Dao Shanghai The  
 People's Republic of China  
 Post Code: 200120  
 Phone : +86-21-58828633  
 Fax : +86-21-58828846