



Advanced Air Cooled CO₂/MAG Welding Torch

BLUE TORCH II

OWNER'S MANUAL 『Parts List』

WT350RD-15D...1U5867
WT350RD-20D...1U5868
WT350RD-25D...1U5869
WT350RD-30D...1U5909

WT350RD-15D
WT350RD-20D
WT350RD-25D
WT350RD-30D

Technical Data

Rated Current : 350A (CO₂) / 350A (MAG)

Duty Cycle : 60% (CO₂) / 35% (MAG)

Wire Size : 0.9mm、1.0mm、1.2mm、1.4mm

(1.2mm Tip is standard.)

Torch Length : 1.5m 2.0m 2.5m 3.0m

Net Weight : 2.3kg 2.6kg 2.9kg 3.3kg



Cooling Method : Air Cooled

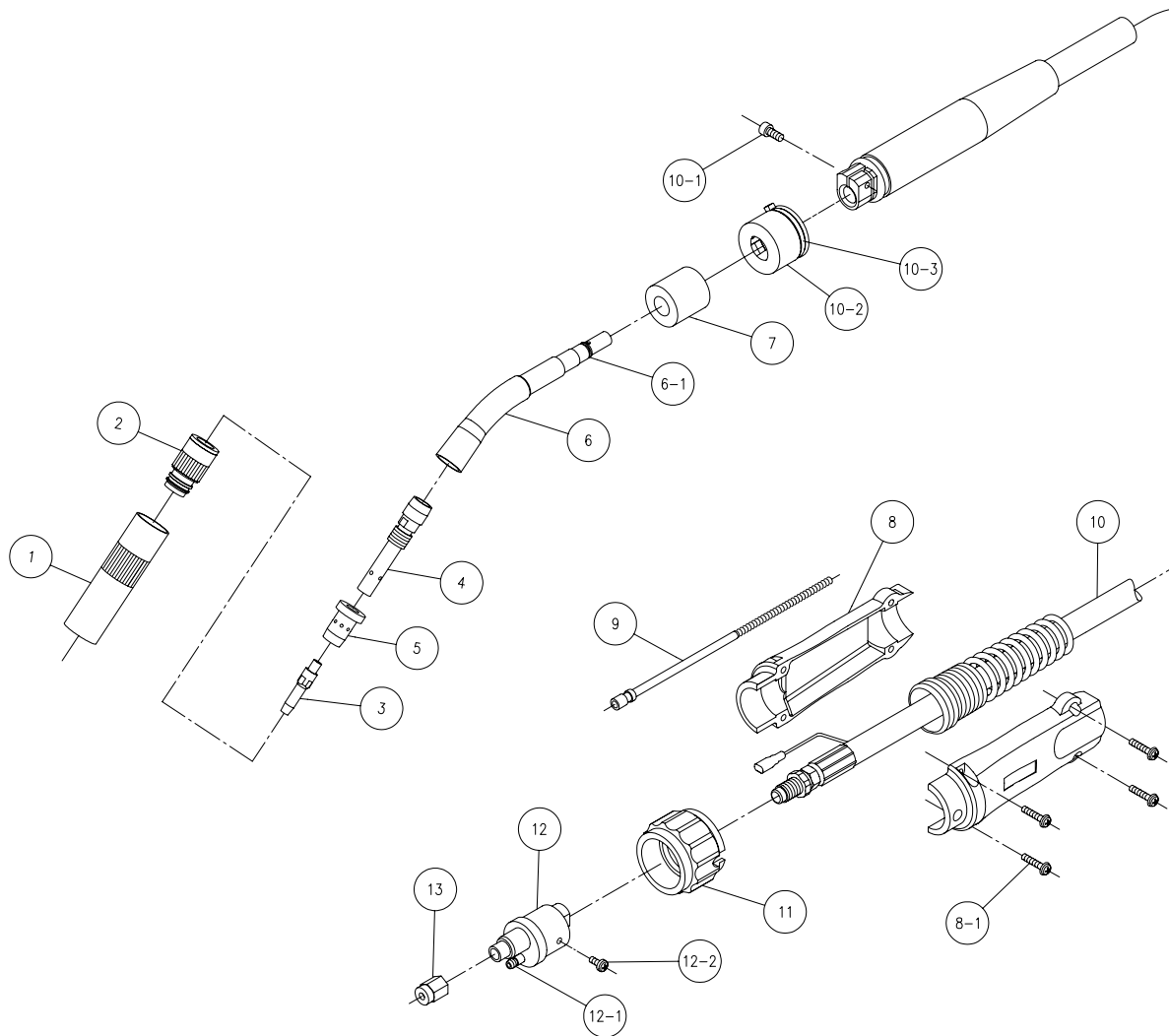

Standard Parts List

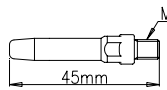
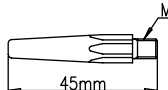
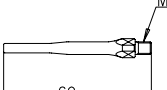
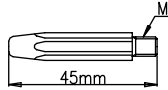

No.	Part Description	Part No.	No.	Part Description	Part No.
①	Nozzle No.10 (I.D.16mm)	U4167G01	⑩	Power Cable (Reinforcing Spring is included.)	
②	Insulator	U4167L00		1.5m	U5861D00
③	Contact Tip (1.2mm)	L7250C04		2.0m	U5862D00
④	Tip Body	U4167G03		2.5m	U5863D00
⑤	Orifice	U4167G02		3.0m	U5907D00
⑥	Torch Body	U5867B00	⑩-1	Bolt with hole(M5 × 14)	100-0310
⑥-1	O-Ring (S9)	3574-001	⑩-2	Sleeve	U5861D03
⑦	Insulating Sleeve	U4222C01	⑩-3	SK-Binder	4739-189
⑧	Cable Support (with Screw)	U5035K00	⑪	Adapter Nut	U4167F03
⑧-1	Small Screw (M4 × 16)	100-0306	⑫	Adapter (with Screw)	U5861F00
⑨	Liner(0.9~1.2mm)		⑫-1	O-Ring	3570-125
	1.5m、2.0m	U5861G01	⑫-2	Small Screw (M4 × 8)	100-0297
	2.5m、3.0m	U4170H02	⑬	Liner Nut	U4167G06

Optional Parts List

Contact Tip					
	FA-Tip (Standard)	T-Tip (For FCW)	Long Tip	CW-Tip (Long Life)	MAG-Tip
Wire Size					
0.9mm	L7250C02	K662B12	U4167H07	-	U4167H14
1.0mm	L7250C03	K980C17	U4167H06	-	U4167H13
1.2mm	L7250C04	K980C19	U4167H05	K990E12	U4167H12
1.4mm	L7250C05	K980C20	-	K990E14	U4167H11

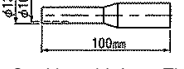
Nozzle			
Standard	Low Current	High Current	Deep and Narrow Space
U4167G01	U4167H01	U4167H16	U4167H04
			
			Combine with Long Tip.

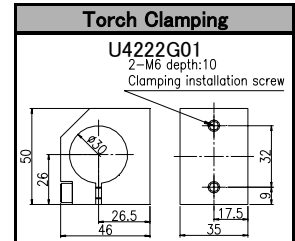

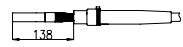
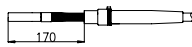
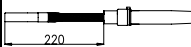
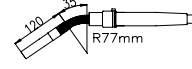
Torch Body			
Straight (Short)	Straight	Straight (Long)	R77, 35°
U5861M00	U5861B00	U5861N00	U5867B00
			
	Straight type Standard		Standard

Inner Liner		
Wire Size	Part No.	These are available for the torch bodies above.
0.9mm~1.2mm	U5003L82	
1.2mm~1.6mm	U5003L26	

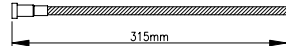

Liner		
Wire Size	Length	Part No.
1.2~1.6mm	1.5m, 2.0m	U5861L01
1.2~1.6mm	2.5m, 3.0m	U4173G04

Direct Plugs

For using this torch with other company's welding machine, change connection part of blue torch II with connection kit below.

Description	Part No.
OTC Black Torch	U5001B00
OTC for CM-302(Wire Feeder)	U5001R00
Panasonic	U5001P00
Euro (Binzel)	U5002E00
Miller	U5002M00
Miller (Separate Gas Hose)	U5002S00
Hobart	U5002H00
Lincoln	U5002L00
DAIDEN FS Series	U5001F00
DAIDEN MOVE Series	U5001M00
Hitachi	U5001H00

Voltage Detecting Cable

Part No. : U 5 3 6 5 H 0 0

(Wire Feeder : CMV-7 4 0 1)

(Welding Power Source : D L -3 5 0)

※ For using this torch combining with equipment above, build voltage detecting cable in the welding torch. For detail, see owner's manual of the welding power source and wire feeder.

External View

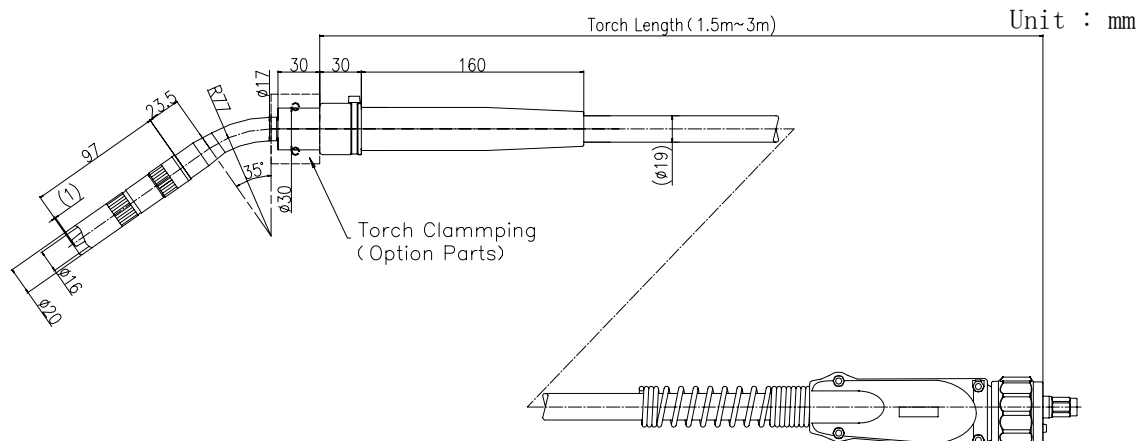

Torch Type

WT 350 RD-15 D

Rated Current
(350A)

Clamping position
D: Fixation type
A: Changeable type

CO₂/MAG
Blue Torch II Series

Torch Body Type
P: Straight
R: Curved

Torch Length
15: 1.5m
20: 2.0m
25: 2.5m
30: 3.0m

Direct Plugs

D : OTC, Tokin
DB : OTC Black Torch*1
DR : OTC for CM-302
P : Panasonic
E : Euro (Binzel)
M : Miller
MS : Miller (Separate Gas Hose)
H : Hobart (Tweco)
L : Lincoln
FS : DAIDEN FS Series
DM : DAIDEN MOVE Series
HT : Hitchi

*1 OTC black torch Power cable adapter, guide adapter and outlet guide are not attached. The parts that you use now or new parts are required. If new parts are required, order parts below separately.

- Power Cable Adapter
- Guide adapter
- Outlet Guide (0.9~1.2)
- Outlet Guide (1.2~1.6)

U2853G00
U785C13
U69C34
U69C35

Attention

Do not pull or move the wire feeder with welding torch, otherwise breaking of the power cable and the cable coating would be tear. If the conductor becomes expose, you may be got electric shocked.

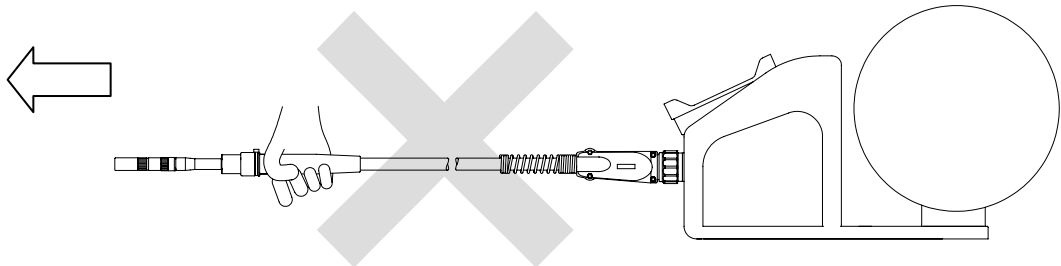

Exchange the power cable when it is damaged. Do not disassemble or repair on clamping part.

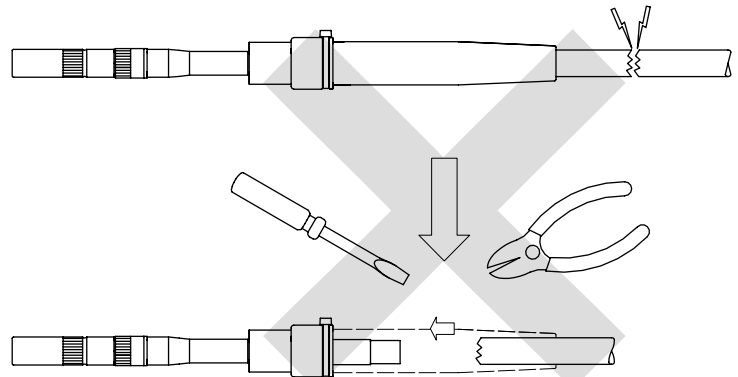

DAIHEN Corporation
5-1, Minamisenrioka,
Settsu-shi, Osaka 566-0021,
Japan
Phone: +81-6-6317-2506,
Fax: +81-6-6317-2583

DAIHEN, INC.
DAYTON OFFICE
1400 Blausler Drive
Tipp City, Ohio 45371, USA
Phone: +1-937-667-0800,
Fax: +1-937-667-0885

OTC DAIHEN EUROPE
GmbH.
Krefelder Str. 677, D-41066
Monchengladbach, F.R.
GERMANY
Phone: +49-2161-69-49710,
Fax: +49-2161-69-49711

OTC (Taiwan) Co.,Ltd.
No. 63-4, Nan Yuan 2 Rd.,
Chung Li, Taoyuan Hsien,
Taiwan R.O.C.
Phone: +886-3-461-3962,
Fax: +886-3-434-2394

OTC DAIHEN Asia Co.,Ltd.
60/86 Moo 19, Navanakorn
Industrial Estate Phase 3,
Klong Nueng, Klong Luang,
Pathumthani 12120
Phone: +66-2-909-4163,
Fax: +66-2-909-4166

OTC Industrial (Shanghai)
Co.,Ltd.
7G Majesty Building, 138 Pu
Dong Da Dao Shanghai The
People's Republic of China
Post Code: 200120
Phone: +86-21-58828633,
Fax: +86-21-58828846